

REAR VIEW

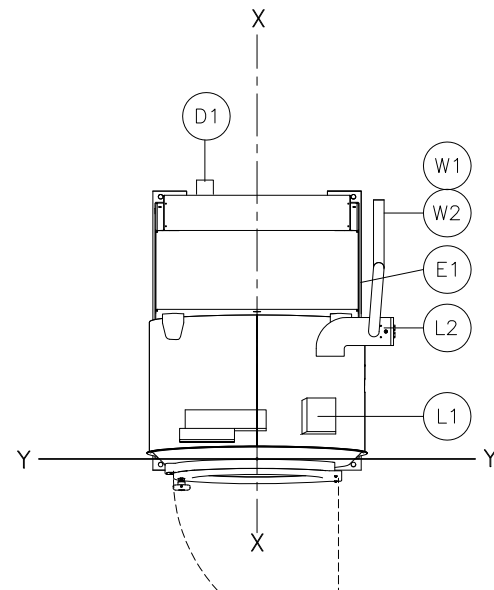

PLAN VIEW

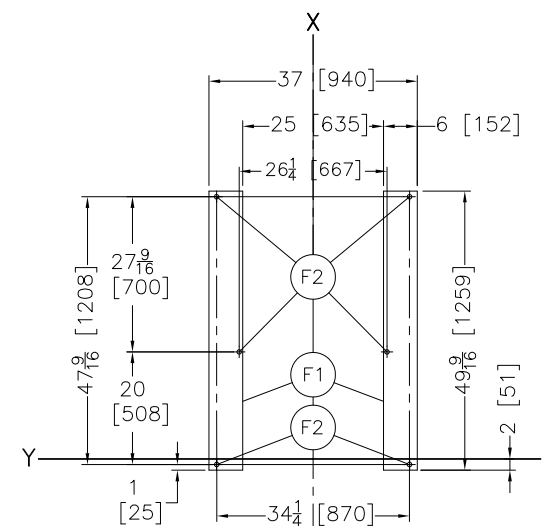

FOUNDATION PLAN VIEW

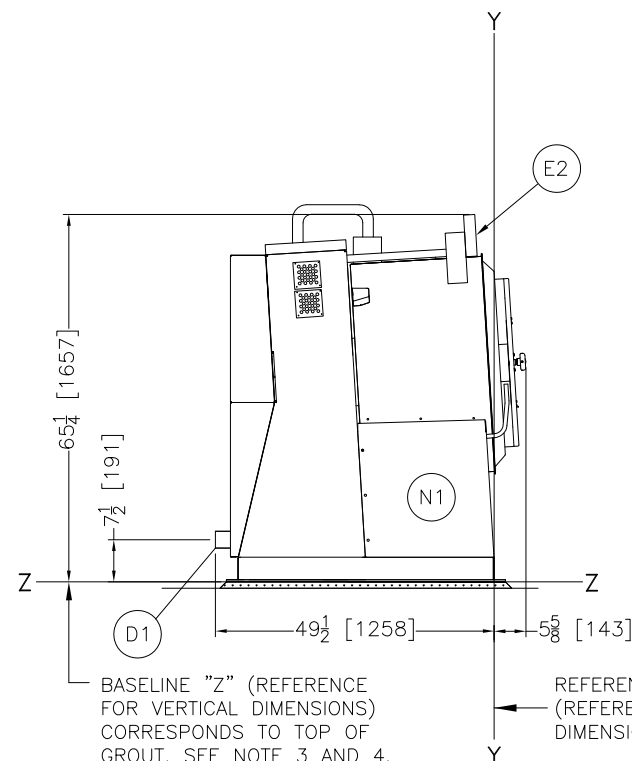

LEFT VIEW

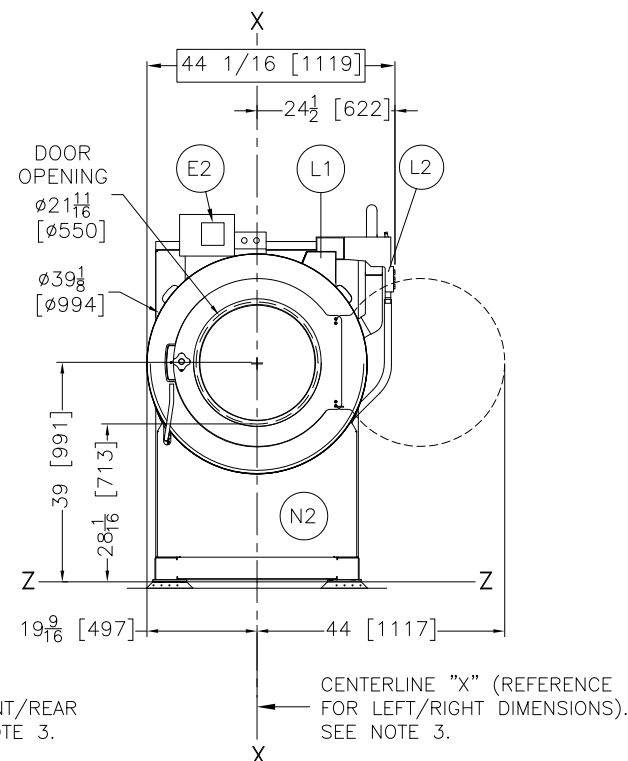

FRONT VIEW

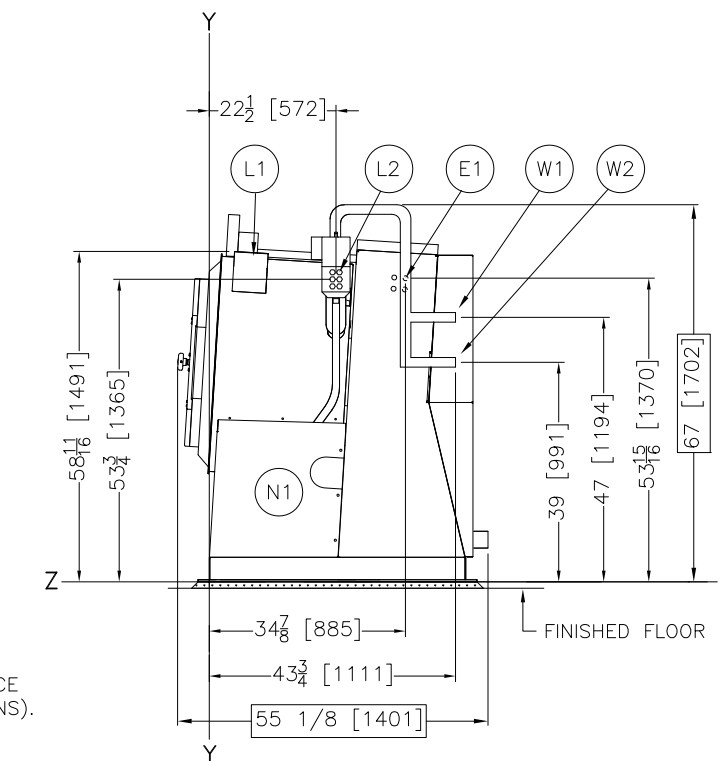

RIGHT VIEW

| | |
|------|--|
| W2 | ELECTRIC COLD WATER INLET, 3/4" NPT CONNECTION |
| W1 | ELECTRIC HOT WATER INLET, 3/4" NPT CONNECTION |
| N2 | REMOVABLE FRONT PANELS |
| N1 | REMOVABLE SIDE PANELS |
| L2 | LIQUID SUPPLY INLETS, SEE NOTE 11. |
| L1 | SOAP CHUTE |
| F2 | (6) 13/16" DIAMETER ANCHOR BOLTS HOLES, USE 5/8" X 6" BOLTS MINIMUM. |
| F1 | FOUNDATION BASE PADS, 2 PLACES. |
| E2 | MILTOUCH CONTROLS™ |
| E1 | MAIN ELECTRICAL CONNECTION |
| D1 | DRAIN, 3" PIPE SOCKET JOINT |
| ITEM | LEGEND |

- NOTES**
- STANDARD LIQUID SUPPLY INLETS COMES WITH THREE SETS OF SIX FITTINGS. ONE SET OF 3/8" FITTINGS, ONE SET OF 1/2" FITTINGS, AND ONE SET OF PLUGS WHICH ARE SHIPPED ON MACHINE.
 - DO NOT PRE-PIPE ANY CLOSER THAN 60 [1524].
 - SHIM TO LEVEL THE MACHINE AND ALLOW FOR 1" [25] MINIMUM GROUT. ANCHOR ALL (6) ANCHOR BOLT HOLES, OR THE WARRANTY WILL BE DECLARED INVALID. USE 5/8" X 6" BOLTS, MINIMUM. SEE INSTALLATION MAINTENANCE MANUAL FOR FURTHER INSTRUCTIONS.
 - WATER INLET PIPING AND BRACKETRY CAN BE EASILY REMOVED TEMPORARILY TO REDUCE OVERALL MACHINE WIDTH FOR PASSAGE THROUGH DOORWAYS.
 - NEVER REDUCE DRAIN PIPING BELOW NPT SIZE OF CONNECTION.
 - AS OF THIS WRITING, THE MINIMUM CLEARANCE REQUIRED BY U.S. NATIONAL ELECTRIC CODES, FROM ELECTRIC BOX TO ANY OBJECT IS:
36 [914] IF OBJECT IS AN UNGROUNDED (INSULATED) WALL.
42 [1067] IF OBJECT IS A GROUNDED WALL (ie. BARE CONCRETE, BRICK, ETC.)
48 [1219] IF OBJECT IS ANY LIVE PART.
CHECK LOCAL ELECTRIC CODES FOR FURTHER RESTRICTIONS.
 - CUSTOMER TO SUPPLY CIRCUIT BREAKER OR FUSED BRANCH CIRCUIT DISCONNECT (SAFETY) SWITCHES WITH LAG TYPE FUSES FROM POWER SOURCE TO MACHINE. A SEPARATE GROUND WIRE MUST BE CONNECTED FROM DISCONNECT TO EQUIPMENT.
 - BASELINE "Z" IS THE SAME FOR ALL MILNOR MACHINES AND IS SHOWN ON ALL DIMENSIONAL DRAWINGS. THE DISTANCE BETWEEN BASELINE "Z" AND THE FINISHED FLOOR MAY VARY (WITH CHANGES IN FLOOR HEIGHT) AS REQUIRED TO INSURE THAT BASELINE "Z" IS HORIZONTAL AND ALL COMPONENTS REQUIRING GROUT ARE SET ON A MINIMUM 1" [25] THICK GROUT BED.
 - USE REFERENCE LINES "X", "Y", AND "Z" TO LOCATE ALL SERVICE CONNECTIONS.
 - NUMBERS IN BRACKETS [] DENOTE DIMENSIONS IN MILLIMETERS.
 - ALL DIMENSIONS SHOWN ARE APPROXIMATE, SUBJECT TO NORMAL MANUFACTURING TOLERANCES, AND TO OCCASIONAL CHANGES WITHOUT NOTICE THROUGH REDESIGN AND/OR RELOCATION OF COMPONENTS, ETC. DO NOT USE FOR CONSTRUCTION UNLESS CERTIFIED, AND IN NO EVENT PRE-PIPE CLOSER THAN FIVE FEET FROM MACHINE. FACTORY MUST BE CONSULTED FOR DIMENSIONS IF MACHINE IS TO BE MOVED THROUGH NARROW OR LOW CORRIDORS OR OPENINGS.

ATTENTION
MOST REGULATORY AUTHORITIES (INCLUDING OSHA IN THE USA) HOLD THE OWNER/USER ULTIMATELY RESPONSIBLE TO MAINTAIN A SAFE WORKING ENVIRONMENT. ACCORDINGLY, THE OWNER/USER MUST RECOGNIZE ALL FORESEEABLE SAFETY HAZARDS, FURNISH SAFETY INSTRUCTIONS AND GUIDANCE TO ALL PERSONNEL WHO MAY COME IN CONTACT WITH THE INSTALLATION, AND PROVIDE ALL NECESSARY ADDITIONAL SAFETY GUARDS, FENCES, RESTRAINTS, DEVICES, ETC., NOT FURNISHED BY THE EQUIPMENT MANUFACTURER OR VENDOR.

ATTENTION
THE FLOOR AND/OR OTHER SUPPORT COMPONENTS MUST HAVE SUFFICIENT STRENGTH (AND RIGIDITY WITH DUE CONSIDERATION FOR NATURAL OR RESONANT FREQUENCY THEREOF) TO WITHSTAND THE FULLY LOADED WEIGHT OF THE MACHINE INCLUDING THE GOODS, THE WATER, AND ANY REPEATED SINUSOIDAL (ROTATING) FORCES GENERATED DURING ITS OPERATION. WRITE THE FACTORY FOR ADDITIONAL MACHINE DATA FOR USE BY A COMPETENT SOIL AND/OR STRUCTURAL ENGINEER.

36021V5Z



BD3621V5ZBE
2015462D

MILNOR PELLERIN MILNOR CORPORATION
P.O. Box 400 Kenner, LA 70063, USA, Phone 504/467-9591,
FAX 504/468-3094, Email: milnorinfo@milnor.com