

REAR VIEW

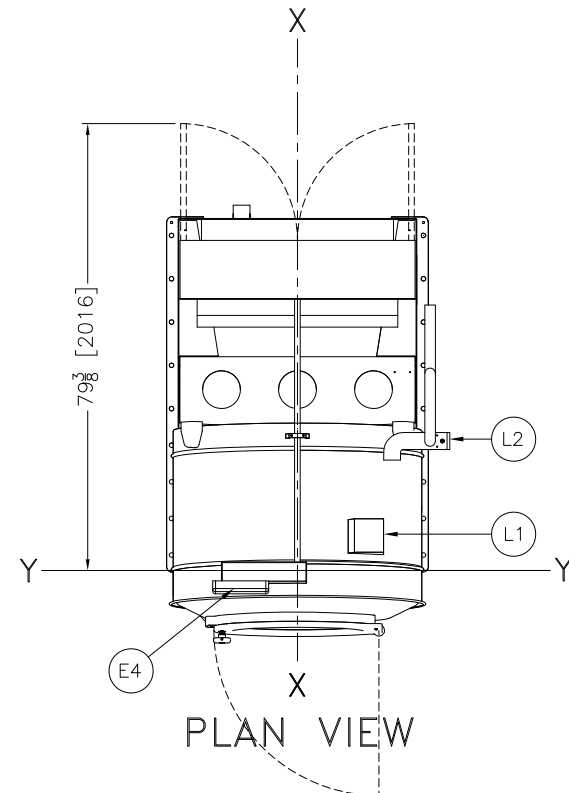

PLAN VIEW

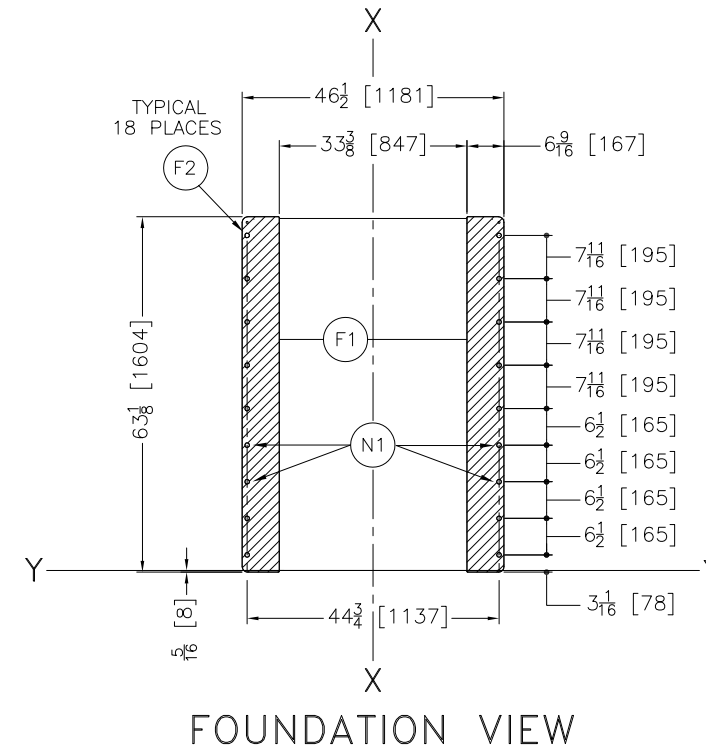

FOUNDATION VIEW

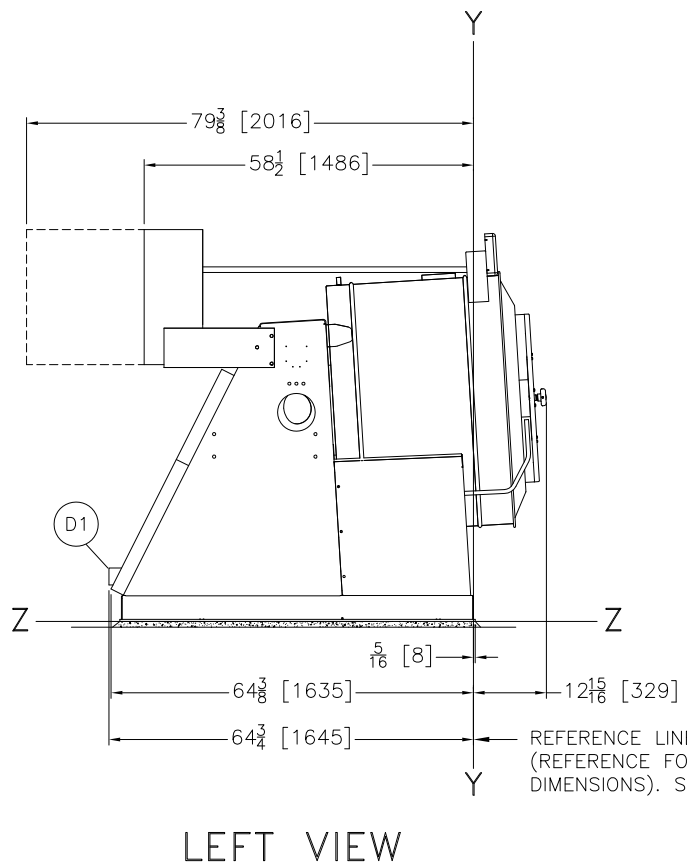

LEFT VIEW

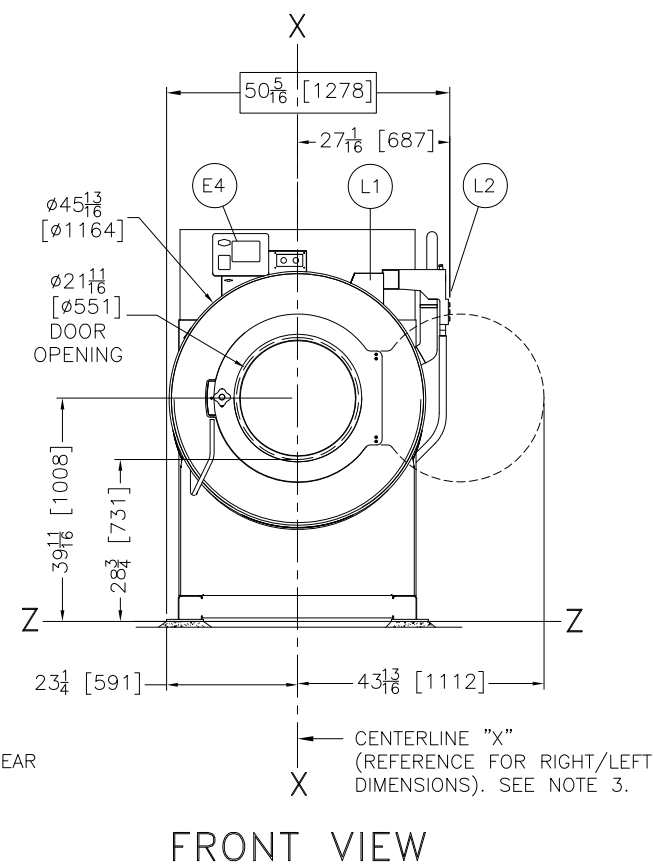

FRONT VIEW

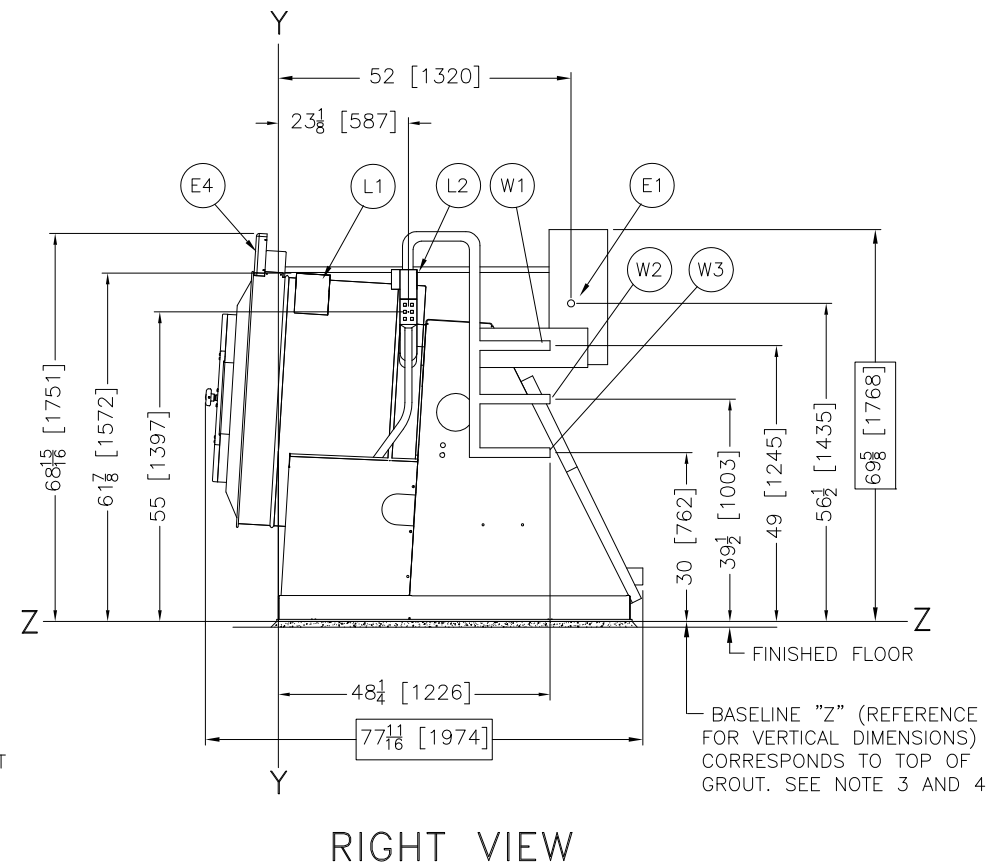

RIGHT VIEW

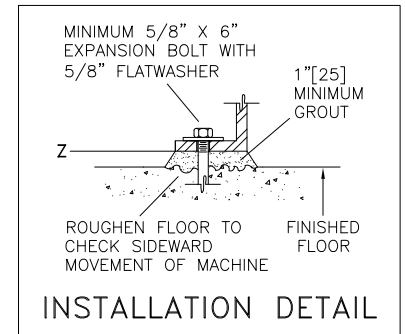
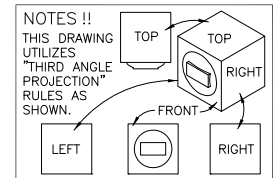

W3	OPTIONAL REUSE WATER INLET, 1-1/4" NPT, V6J
W2	ELECTRIC COLD WATER INLET, 1-1/4" NPT, V6J
W1	ELECTRIC HOT WATER INLET, 1-1/4" NPT, V6J
N1	SEE NOTE 9.
L2	LIQUID SUPPLY INLETS.
L1	STANDARD SOAP CHUTE.
F2	(18) 13/16" DIAMETER ANCHOR BOLTS HOLES, USE 5/8" X 6" BOLTS MINIMUM.
F1	FOUNDATION BASE PADS, 2 PLACES.
E4	MILTOUCH CONTROLS™
E3	LOW VOLTAGE CONTROL BOX.
E2	HIGH VOLTAGE CONTROL BOX.
E1	MAIN ELECTRICAL CONNECTION.
D1	DRAIN TO REAR, 3" PIPE SOCKET JOINT.
ITEM	LEGEND

- NOTES**
- SHIM TO LEVEL THE MACHINE AND ALLOW FOR 1" [25] MINIMUM GROUT. ANCHOR ALL (18) ANCHOR BOLT HOLES (SEE NOTE 9.) OR THE WARRANTY WILL BE DECLARED INVALID. USE 5/8" X 6" BOLTS, MINIMUM. SEE INSTALLATION MAINTENANCE MANUAL FOR FURTHER INSTRUCTIONS.
  - WATER INLET PIPING AND BRACKETRY CAN BE EASILY REMOVED TO TEMPORARILY REDUCE OVERALL MACHINE WIDTH FOR PASSAGE THROUGH DOORWAYS.
  - IF ABSOLUTELY NECESSARY, THE MACHINE MAY SPAN A DRAIN TROUGH UP TO 15" [381] WIDE (THUS ELIMINATING UP TO 2 ANCHOR BOLTS PER SIDE, BUT ONLY THOSE IDENTIFIED (N1)).
  - ENTIRE BASE OF MACHINE MUST BE CONTINUOUSLY SUPPORTED. IF MACHINE IS TO BE INSTALLED OVER A DRAIN TROUGH, THE MACHINE MUST BE MOUNTED TO A PEDESTAL BASE, NOT SUPPLIED BY P.M.C.
  - NEVER REDUCE DRAIN PIPING BELOW NPT SIZE OF CONNECTIONS.
  - AS OF THIS WRITING, THE MINIMUM CLEARANCE REQUIRED BY U.S. NATIONAL ELECTRIC CODES, FROM ELECTRIC BOX TO ANY OBJECT IS:  
36 [914] IF OBJECT IS AN UNGROUNDED (INSULATED) WALL.  
42 [1067] IF OBJECT IS A GROUNDED WALL (ie. BARE CONCRETE, BRICK, ETC.)  
48 [1219] IF OBJECT IS ANY LIVE PART.  
CHECK LOCAL ELECTRIC CODES FOR FURTHER RESTRICTIONS.
  - CUSTOMER TO SUPPLY CIRCUIT BREAKER OR FUSED BRANCH CIRCUIT DISCONNECT (SAFETY) SWITCHES WITH LAG TYPE FUSES FROM POWER SOURCE TO MACHINE. A SEPARATE GROUND WIRE MUST BE CONNECTED FROM DISCONNECT TO EQUIPMENT.
  - BASELINE "Z" IS THE SAME FOR ALL MILNOR MACHINES AND IS SHOWN ON ALL DIMENSIONAL DRAWINGS. THE DISTANCE BETWEEN BASELINE "Z" AND THE FINISHED FLOOR MAY VARY (WITH CHANGES IN FLOOR HEIGHT) AS REQUIRED TO INSURE THAT BASELINE "Z" IS HORIZONTAL AND ALL COMPONENTS REQUIRING GROUT ARE SET ON A MINIMUM 1" [25] THICK GROUT BED.
  - USE REFERENCE LINES "X", "Y", AND "Z" TO LOCATE ALL SERVICE CONNECTIONS.
  - NUMBERS IN BRACKETS [ ] DENOTE DIMENSIONS IN MILLIMETERS.
  - ALL DIMENSIONS SHOWN ARE APPROXIMATE, SUBJECT TO NORMAL MANUFACTURING TOLERANCES, AND TO OCCASIONAL CHANGES WITHOUT NOTICE THROUGH REDESIGN AND/OR RELOCATION OF COMPONENTS, ETC. DO NOT USE FOR CONSTRUCTION UNLESS CERTIFIED, AND IN NO EVENT PRE-PIPE CLOSER THAN FIVE FEET FROM MACHINE. FACTORY MUST BE CONSULTED FOR DIMENSIONS IF MACHINE IS TO BE MOVED THROUGH NARROW OR LOW CORRIDORS OR OPENINGS.
- ATTENTION**  
MOST REGULATORY AUTHORITIES (INCLUDING OSHA IN THE USA) HOLD THE OWNER/USER ULTIMATELY RESPONSIBLE TO MAINTAIN A SAFE WORKING ENVIRONMENT. ACCORDINGLY, THE OWNER/USER MUST RECOGNIZE ALL FORESEEABLE SAFETY HAZARDS, FURNISH SAFETY INSTRUCTIONS AND GUIDANCE TO ALL PERSONNEL WHO MAY COME IN CONTACT WITH THE INSTALLATION, AND PROVIDE ALL NECESSARY ADDITIONAL SAFETY GUARDS, FENCES, RESTRAINTS, DEVICES, ETC., NOT FURNISHED BY THE EQUIPMENT MANUFACTURER OR VENDOR.
- ATTENTION**  
THE FLOOR AND/OR OTHER SUPPORT COMPONENTS MUST HAVE SUFFICIENT STRENGTH (AND RIGIDITY WITH DUE CONSIDERATION FOR NATURAL OR RESONANT FREQUENCY THEREOF) TO WITHSTAND THE FULLY LOADED WEIGHT OF THE MACHINE INCLUDING THE GOODS, THE WATER, AND ANY REPEATED SINUSOIDAL (ROTATING) FORCES GENERATED DURING ITS OPERATION. WRITE THE FACTORY FOR ADDITIONAL MACHINE DATA FOR USE BY A COMPETENT SOIL AND/OR STRUCTURAL ENGINEER.

42026V6Z

DM 0 0.5M 1M DWG# BD4226V6ZBE 2015462D

INCHES 0 12 24 36

**MILNOR** PELLERIN MILNOR CORPORATION  
P.O. Box 400 Kenner, LA 70063, USA, Phone 504/467-9591, FAX 504/468-3094, Email: milnorinfo@milnor.com