

REAR VIEW

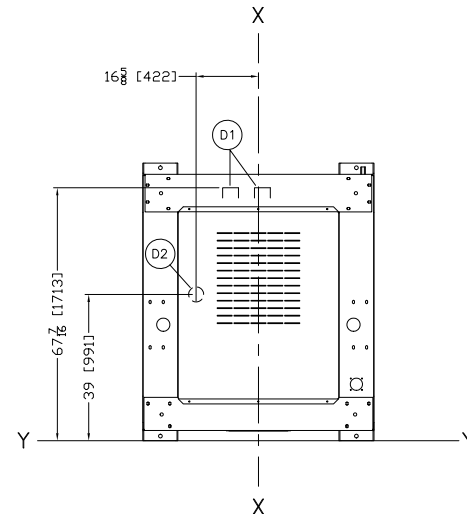

PLAN VIEW

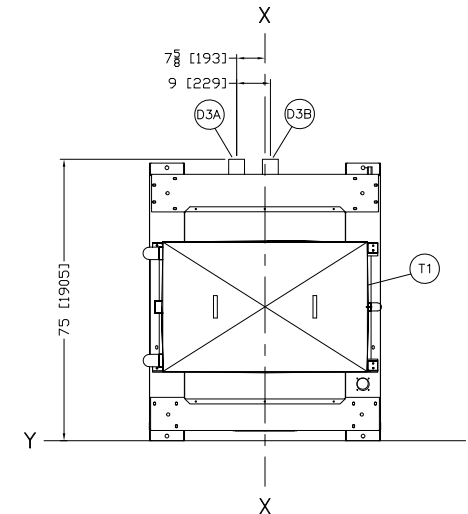

PLAN VIEW  
RECIRCULATION

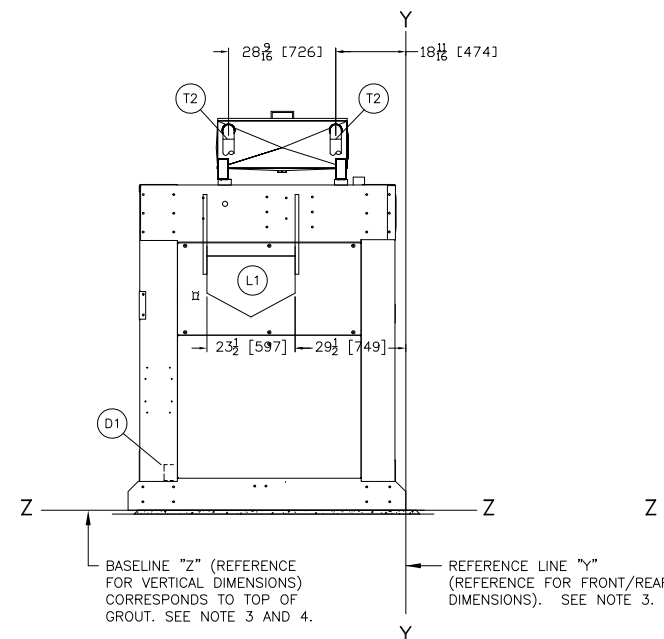

LEFT VIEW

BASELINE "Z" (REFERENCE FOR VERTICAL DIMENSIONS) CORRESPONDS TO TOP OF GROUT. SEE NOTE 3 AND 4.

REFERENCE LINE "Y" (REFERENCE FOR FRONT/REAR DIMENSIONS). SEE NOTE 3.

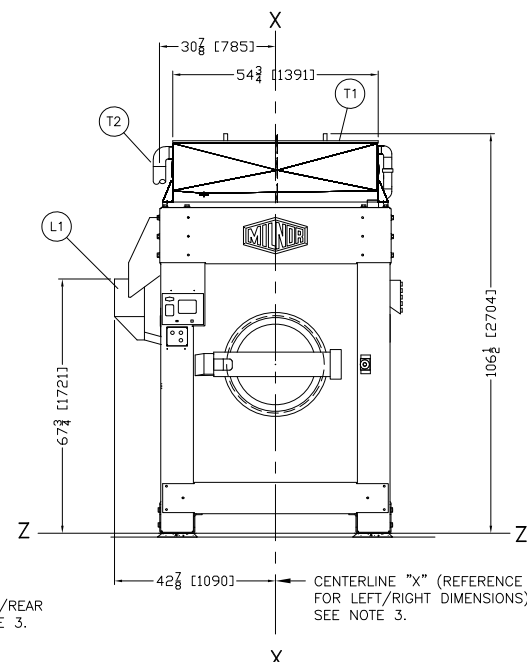

FRONT VIEW

CENTERLINE "X" (REFERENCE FOR LEFT/RIGHT DIMENSIONS). SEE NOTE 3.

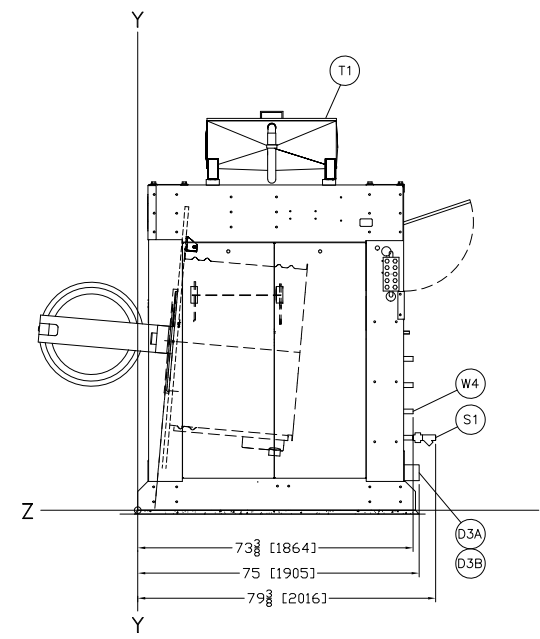

RIGHT VIEW

W4	THIRD (OR REUSE) WATER INLET, ELECTRICALLY OPERATED, 1-1/4" NPT CONNECTION
T2	REUSE TANK OVERFLOW TO SEWER, 3" ID HOSE TO SEWER PROVIDED
T1	OPTIONAL REUSE TANK
S1	OPTIONAL AIR-OPERATED STEAM INLET, Y-STRAINER REMOVED FOR SHIPPING MUST BE ADDED AT INSTALLATION, 1" NPT CONNECTION
L4	5 COMPARTMENT SUPPLY
D3B	DUAL DRAINS FOR RECIRCULATION, DRAIN TO REUSE, 3" PIPE SOCKET JOINT
D3A	DUAL DRAINS FOR RECIRCULATION, DRAIN TO SEWER, 3" PIPE SOCKET JOINT
D2	OPTIONAL SINGLE DRAIN DOWN, 3" PIPE SOCKET JOINT CONNECTION
D1	OPTIONAL DUAL DRAIN, 3" PIPE SOCKET JOINT CONNECTIONS
ITEM	LEGEND

NOTES

- AS OF THIS WRITING, THE MINIMUM CLEARANCE REQUIRED BY U.S. NATIONAL ELECTRIC CODES, FROM ELECTRIC BOX TO ANY OBJECT IS:  
 36 [914] IF OBJECT IS AN UNGROUNDED (INSULATED) WALL.  
 42 [1067] IF OBJECT IS A GROUNDED WALL (ie. BARE CONCRETE, BRICK, ETC.)  
 48 [1219] IF OBJECT IS ANY LIVE PART.  
 CHECK LOCAL ELECTRIC CODES FOR FURTHER RESTRICTIONS.
- CUSTOMER TO SUPPLY CIRCUIT BREAKER OR FUSED BRANCH CIRCUIT DISCONNECT (SAFETY) SWITCHES WITH LAG TYPE FUSES FROM POWER SOURCE TO MACHINE. A SEPARATE GROUND WIRE MUST BE CONNECTED FROM DISCONNECT TO EQUIPMENT.
- BASELINE "Z" IS THE REFERENCE FOR ALL VERTICAL DIMENSIONS. ON MACHINES WITH FIXED BASE PADS, BASELINE "Z" CORRESPONDS TO THE BOTTOM OF THE BASE PAD. ON MACHINES WITH ADJUSTABLE FEET, BASELINE "Z" CORRESPONDS TO THE BOTTOM OF THE FEET WHEN ADJUSTED SO THAT THE MACHINE IS AT ITS MINIMUM ACCEPTABLE HEIGHT. ON TRAVELING SHUTTLES, BASELINE "Z" CORRESPONDS TO THE BOTTOM OF THE BOTTOM RAIL. THE DISTANCE BETWEEN BASELINE "Z" AND THE FINISHED FLOOR WILL VARY AS REQUIRED TO ENSURE BASELINE "Z" IS HORIZONTAL AND ANY INTERFACING MACHINES REQUIRING GROUT ARE SET ON A MINIMUM 1" [25] THICK GROUT BED.
- USE REFERENCE LINES "X", "Y", AND "Z" TO LOCATE ALL SERVICE CONNECTIONS.
- NUMBERS IN BRACKETS [ ] DENOTE DIMENSIONS IN MILLIMETERS.
- ALL DIMENSIONS SHOWN ARE APPROXIMATE, SUBJECT TO NORMAL MANUFACTURING TOLERANCES, AND TO OCCASIONAL CHANGES WITHOUT NOTICE THROUGH REDESIGN AND/OR RELOCATION OF COMPONENTS, ETC. DO NOT USE FOR CONSTRUCTION UNLESS CERTIFIED, AND IN NO EVENT PRE-PIPE CLOSER THAN FIVE FEET FROM MACHINE. FACTORY MUST BE CONSULTED FOR DIMENSIONS IF MACHINE IS TO BE MOVED THROUGH NARROW OR LOW CORRIDORS OR OPENINGS.

ATTENTION

MOST REGULATORY AUTHORITIES (INCLUDING OSHA IN THE USA) HOLD THE OWNER/USER ULTIMATELY RESPONSIBLE TO MAINTAIN A SAFE WORKING ENVIRONMENT. ACCORDINGLY, THE OWNER/USER MUST RECOGNIZE ALL FORESEEABLE SAFETY HAZARDS, FURNISH SAFETY INSTRUCTIONS AND GUIDANCE TO ALL PERSONNEL WHO MAY COME IN CONTACT WITH THE INSTALLATION, AND PROVIDE ALL NECESSARY ADDITIONAL SAFETY GUARDS, FENCES, RESTRAINTS, DEVICES, ETC., NOT FURNISHED BY THE EQUIPMENT MANUFACTURER OR VENDOR.

ATTENTION

THE FLOOR AND/OR OTHER SUPPORT COMPONENTS MUST HAVE SUFFICIENT STRENGTH (AND RIGIDITY WITH DUE CONSIDERATION FOR NATURAL OR RESONANT FREQUENCY THEREOF) TO WITHSTAND THE FULLY LOADED WEIGHT OF THE MACHINE INCLUDING THE GOODS, THE WATER, AND ANY REPEATED SINUSOIDAL (ROTATING) FORCES GENERATED DURING ITS OPERATION. WRITE THE FACTORY FOR ADDITIONAL MACHINE DATA FOR USE BY A COMPETENT SOIL AND/OR STRUCTURAL ENGINEER.

42026X7R OPTIONS

