

REAR VIEW

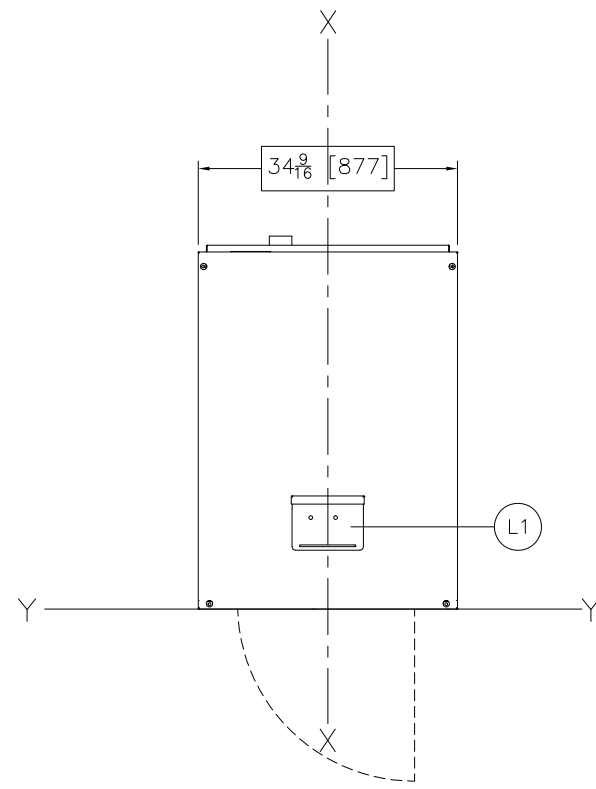

PLAN VIEW

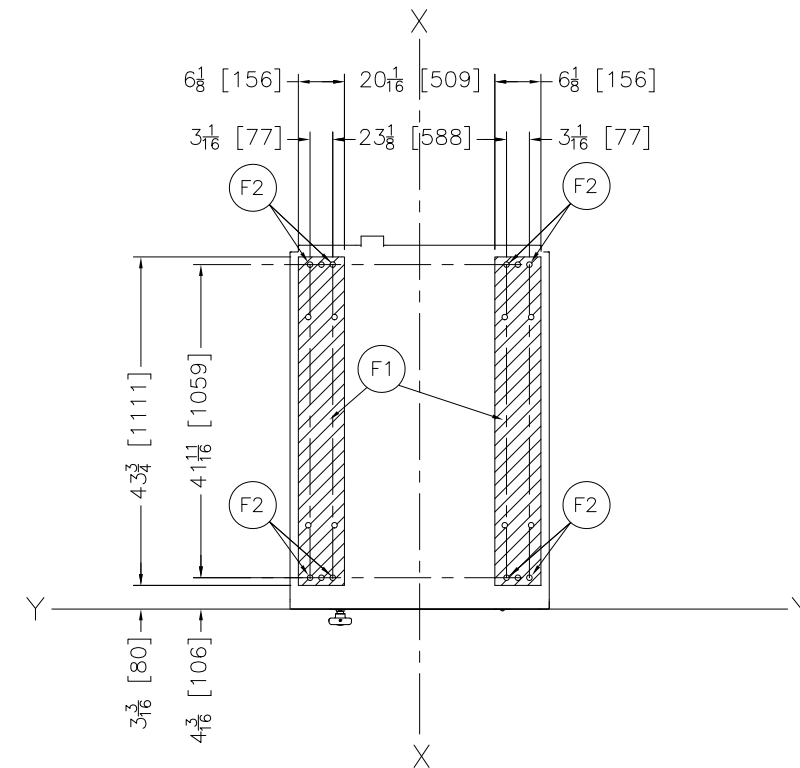

FOUNDATION PLAN

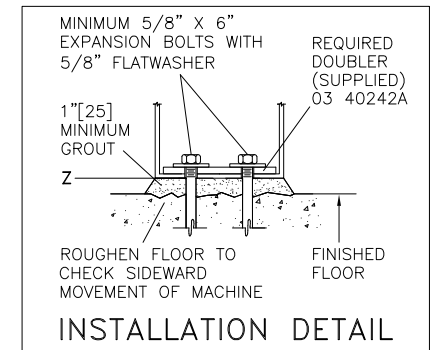

W3	HOT WATER FOR SOAP CHUTE INLET, 3/4" GARDEN HOSE CONNECTION WITH 1/2" HOSE
W2	HOT WATER INLET, 3/4" GARDEN HOSE
W1	COLD WATER INLET, 3/4" GARDEN HOSE
S1	OPTIONAL AIR-OPERATED STEAM INLET 1/2"NPT, Y-STRAINER REMOVED FOR SHIPPING MUST BE ADDED AT INSTALLATION REQUIRES AIR (A2)
L2	PERISTALTIC CHEMICAL INLETS: MWT27E5 (3 PORTS), MWT27X5 (5 PORTS), MWT27J5 (5 PORTS)
L1	SOAP CHUTE
F2	(8) 3/4" ANCHOR BOLT HOLES, USE 5/8" X 6" BOLTS MINIMUM
F1	FOUNDATION BASE PADS
E1	MAIN ELECTRICAL CONNECTION
D1	DRAIN 3" ID HOSE CONNECTION
B1	COIN ACCEPTOR, MWT27E5 ONLY
A2	1/4"NPT AIR INLET, ONLY WITH OPTIONAL AIR-OPERATED STEAM, CUSTOMER MUST SUPPLY AIR STRAINER.
A1	VACUUM BREAKER, NO CONNECTION
ITEM	LEGEND

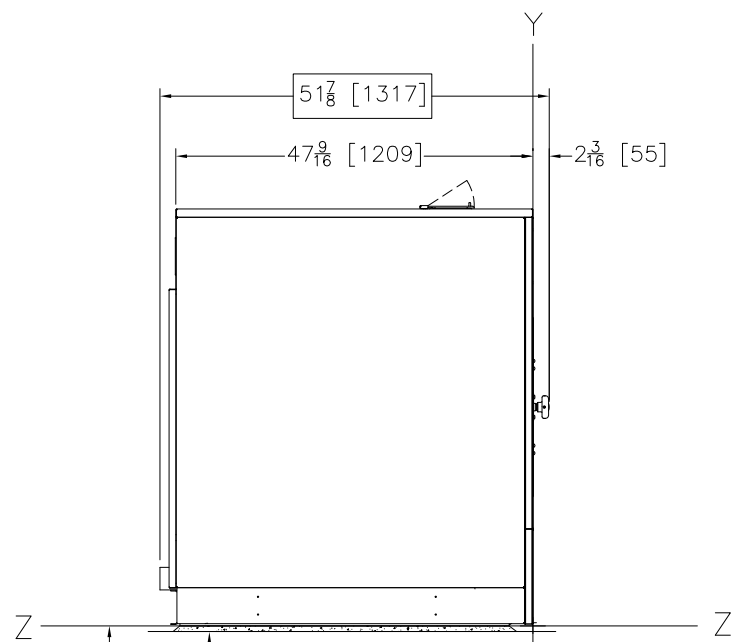

LEFT VIEW

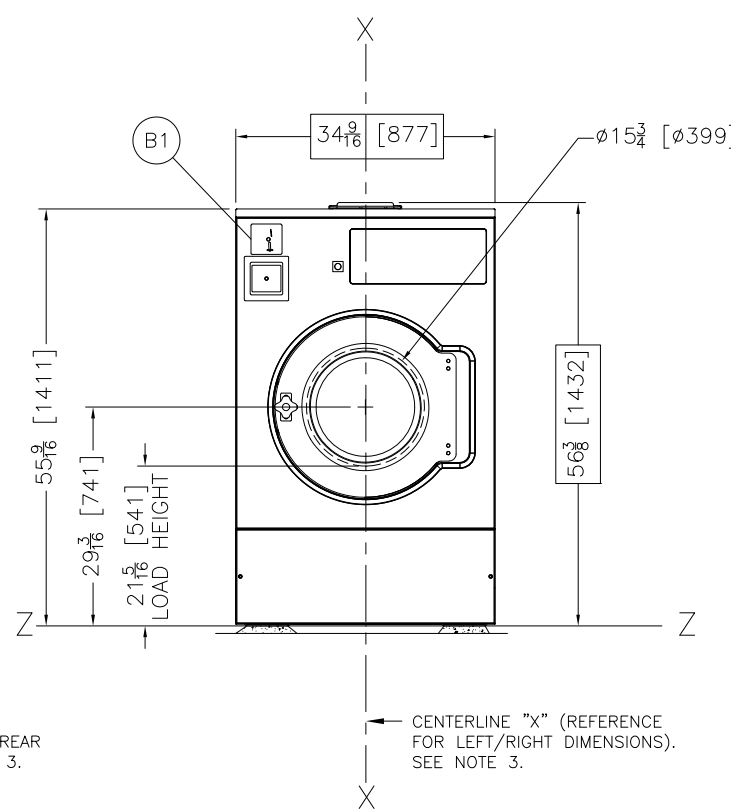

FRONT VIEW

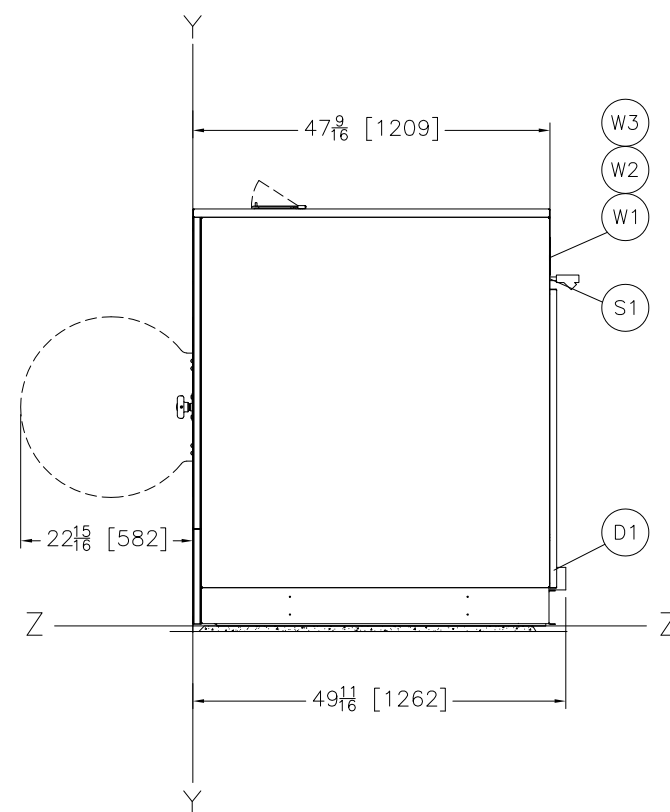

RIGHT VIEW

BASELINE "Z" (REFERENCE FOR VERTICAL DIMENSIONS). SEE NOTE 4.

REFERENCE LINE "Y" (REFERENCE FOR FRONT/REAR DIMENSIONS). SEE NOTE 3.

CENTERLINE "X" (REFERENCE FOR LEFT/RIGHT DIMENSIONS). SEE NOTE 3.

**NOTES**

7 SHIM TO LEVEL THE MACHINE AND ALLOW FOR 1" [25] MINIMUM GROUT. ANCHOR ALL (8) ANCHOR BOLT HOLES, OR THE WARRANTY WILL BE DECLARED INVALID. USE 5/8" X 6" BOLTS, MINIMUM, WITH DOUBLER BOLT DOWN PLATES (SUPPLIED). SEE INSTALLATION MAINTENANCE MANUAL FOR FURTHER INSTRUCTIONS.

6 AS OF THIS WRITING, THE MINIMUM CLEARANCE REQUIRED BY U.S. NATIONAL ELECTRIC CODES, FROM ELECTRIC BOX TO ANY OBJECT IS:  
 36 [914] IF OBJECT IS AN UNGROUNDED (INSULATED) WALL.  
 42 [1067] IF OBJECT IS A GROUNDED WALL (ie. BARE CONCRETE, BRICK, ETC.).  
 48 [1219] IF OBJECT IS ANY LIVE PART.  
 CHECK LOCAL ELECTRIC CODES FOR FURTHER RESTRICTIONS.

5 CUSTOMER TO SUPPLY CIRCUIT BREAKER OR FUSED BRANCH CIRCUIT DISCONNECT (SAFETY) SWITCHES WITH LAG TYPE FUSES FROM POWER SOURCE TO MACHINE. A SEPARATE GROUND WIRE MUST BE CONNECTED FROM DISCONNECT TO EQUIPMENT.

4 BASELINE "Z" IS THE REFERENCE FOR ALL VERTICAL DIMENSIONS. ON MACHINES WITH FIXED BASE PADS, BASELINE "Z" CORRESPONDS TO THE BOTTOM OF THE BASE PAD. ON MACHINES WITH ADJUSTABLE FEET, BASELINE "Z" CORRESPONDS TO THE BOTTOM OF THE FEET WHEN ADJUSTED SO THAT THE MACHINE IS AT ITS MINIMUM ACCEPTABLE HEIGHT. ON TRAVELING SHUTTLES, BASELINE "Z" CORRESPONDS TO THE BOTTOM OF THE BOTTOM RAIL. THE DISTANCE BETWEEN BASELINE "Z" AND THE FINISHED FLOOR WILL VARY AS REQUIRED TO ENSURE BASELINE "Z" IS HORIZONTAL AND ANY INTERFACING MACHINES REQUIRING GROUT ARE SET ON A MINIMUM 1" [25] THICK GROUT BED.

3 USE REFERENCE LINES "X", "Y", AND "Z" TO LOCATE ALL SERVICE CONNECTIONS.

2 NUMBERS IN BRACKETS [ ] DENOTE DIMENSIONS IN MILLIMETERS.

1 ALL DIMENSIONS SHOWN ARE APPROXIMATE, SUBJECT TO NORMAL MANUFACTURING TOLERANCES, AND TO OCCASIONAL CHANGES WITHOUT NOTICE THROUGH REDESIGN AND/OR RELOCATION OF COMPONENTS, ETC. DO NOT USE FOR CONSTRUCTION UNLESS CERTIFIED, AND IN NO EVENT PRE-PIPE CLOSER THAN FIVE FEET FROM MACHINE. FACTORY MUST BE CONSULTED FOR DIMENSIONS IF MACHINE IS TO BE MOVED THROUGH NARROW OR LOW CORRIDORS OR OPENINGS.

**ATTENTION**

MOST REGULATORY AUTHORITIES (INCLUDING OSHA IN THE USA) HOLD THE OWNER/USER ULTIMATELY RESPONSIBLE TO MAINTAIN A SAFE WORKING ENVIRONMENT. ACCORDINGLY, THE OWNER/USER MUST RECOGNIZE ALL FORESEEABLE SAFETY HAZARDS, FURNISH SAFETY INSTRUCTIONS AND GUIDANCE TO ALL PERSONNEL WHO MAY COME IN CONTACT WITH THE INSTALLATION, AND PROVIDE ALL NECESSARY ADDITIONAL SAFETY GUARDS, FENCES, RESTRAINTS, DEVICES, ETC., NOT FURNISHED BY THE EQUIPMENT MANUFACTURER OR VENDOR.

**ATTENTION**

THE FLOOR AND/OR OTHER SUPPORT COMPONENTS MUST HAVE SUFFICIENT STRENGTH (AND RIGIDITY WITH DUE CONSIDERATION FOR NATURAL OR RESONANT FREQUENCY THEREOF) TO WITHSTAND THE FULLY LOADED WEIGHT OF THE MACHINE INCLUDING THE GOODS, THE WATER, AND ANY REPEATED SINUSOIDAL (ROTATING) FORCES GENERATED DURING ITS OPERATION. WRITE THE FACTORY FOR ADDITIONAL MACHINE DATA FOR USE BY A COMPETENT SOIL AND/OR STRUCTURAL ENGINEER.

MCT27E5, MWT27E5, MWT27X5, MWT27J5

DM 0 0.25  
INCHES 0 12

DWG# BDMWT27X5AE  
2020042D

**MILNOR** PELLERIN MILNOR CORPORATION  
 P.O. Box 400 Kenner, LA 70063, USA, Phone 504/467-9591,  
 FAX 504/468-3094, Email: milnorinfo@milnor.com