



Manual Number: MCWMCA01  
Edition (ECN): 2024355A

# Installation, Parts, and Service

## MWF63J7, MWF63Z7, MWF77J7, MWF77Z7







2.2.1 Disclaimer of Responsibility .....	38
2.2.2 Major Design Considerations .....	38
2.2.3 Primary Information Sources .....	39
2.3 Prevent Damage from Chemical Supplies and Chemical Systems .....	39
2.3.1 How Chemical Supplies Can Cause Damage.....	40
• Dangerous Chemical Supplies and Wash Formulas.....	40
• Incorrect Configuration or Connection of Equipment .....	40
2.3.2 Equipment and Procedures That Can Prevent Damage.....	42
• Use the chemical manifold supplied. ....	42
• Close the line.....	43
• Do not let a vacuum occur.....	43
• Flush the chemical tube with water.....	43
• Put the chemical tube fully below the inlet.....	43
• Prevent leaks. ....	43
3 Installation Procedures .....	44
3.1 Handling a Washer-extractor from Delivery to Final Location .....	44
3.1.1 Notices.....	44
• Qualified Personnel Only.....	44
• Disclaimer .....	44
• Other Tasks .....	44
3.1.2 Facility Prerequisites .....	45
3.1.3 Rigger Precautions.....	45
3.1.4 Technician Precautions .....	47
• Can the Door(s) Be Opened Before Utilities are Connected? .....	49
3.2 Connection Precautions for Washer-extractors .....	49
3.2.1 Notices.....	50
• Machine Must Be Anchored .....	50
3.2.2 Utility Requirements and Related Information .....	50
3.2.3 Plumber Precautions.....	51
3.2.4 Electrician Precautions .....	52
3.2.5 Chemical Supplier Precautions.....	53
4 Drive Assemblies.....	54
Drive MWF63J7, MWF63Z7, MWF77J7, MWF77Z7, MWF63C7, MWF63Y7, MWF77C7, MWF77Y7.....	55
Bearing MWF36, MWF45, MWF63, MWF77 .....	56
5 Suspension.....	63
Suspension MWF63J7, MWF63Z7, MWF77J7, MWF77Z7, MWF63C7, MWF63Y7, MWF77C7, MWF77Y7.....	64
Shocks MWF63J8, MWF63Z8, MWF77J8, MWF77Z8 .....	66
6 Door Assemblies .....	68
26” Door MWF63J7, MWF63Z7, MWF77J7, MWF77Z7, MWF63C7, MWF63Y7, MWF77C7, MWF77Y7.....	70
Door Latch MWF36J8, MWF36Z8; MWF45J8, MWF45Z8; MWF63J7, MWF63Z7; MWF77J7, MWF77Z7; MWF63C7, MWF63Y7; MWF77C7, MWF77Y7 .....	74
7 Chemical Supply .....	75
Soap Chute MWF36J8, MWF36Z8; MWF45J8, MWF45Z8; MWF63J7, MWF63Z7; MWF77J7, MWF77Z7; MWF63C7, MWF63Y7; MWF77C7, MWF77Y7 .....	76
Peristaltic Supply MWF36J8, MWF36Z8; MWF45J8, MWF45Z8; MWF63J7, MWF63Z7; MWF77J7, MWF77Z7; MWF63C7, MWF63Y7; MWF77C7, MWF77Y7. ....	78

5 Compartment Supply MWF36J8, MWF36Z8; MWF45J8, MWF45Z8; MWF63J7, MWF63Z7; MWF77J7, MWF77Z7; MWF63C7, MWF63Y7; MWF77C7, MWF77Y7 .....	80
8 Water and Steam .....	82
Water and Steam MWF63J7, MWF63Z7, MWF63C7, MWF63Y7, MWF77J7, MWF77Z7, MWF77C7, MWF77Y7 .....	83
Drain Valve to Rear MWF36J8, MWF36Z8; MWF45J8, MWF45Z8; MWF63J7, MWF63Z7; MWF77J7, MWF77Z7 .....	86
9 Pneumatic Assemblies .....	87
Pneumatic Schematic MWF63J7, MWF63Z7, MWF77J7, MWF77Z7 .....	88
10 Control and Sensing .....	90
Water Level & Temperature Sensor MWF45J8/Z8, MWF63J7/Z7, MWF77J7/Z7, MWF100J7/ Z7, MWF125J7/Z7; MWF45C8/Y8, MWF63C7/Y7, MWF77C7/Y7, MWF100C7/Y7, MWF125C7/Y7 .....	91
11 Dimensional Drawings .....	93
BDMWF63JAE/2020042 — MWF63J7, MWF63Z7 .....	95
BDMWF63JAB/2020302 — MWF63J7, MWF63Z7 (Options) .....	96
BDMWF77JBE/2023262D — MWF77J7, MWF77Z7 .....	97
BDMWF77JBB/2023072D — MWF77J7, MWF77Z7 (Options) .....	98

## Figures

Figure 1	The Bolts in Milnor® Equipment .....	28
Figure 2	Apply Threadlocker in a Blind Hole .....	34
Figure 3	Apply Threadlocker in a Through Hole .....	35
Figure 4	Use heat for disassembly of fasteners with threadlocker .....	35
Figure 5	How Rotating Forces Act On the Foundation .....	39
Figure 6	Incorrect Configurations That Let the Chemical Supply Go In the Ma- chine by a Siphon .....	41
Figure 7	Incorrect Configurations That Let the Chemical Supply Go In the Ma- chine by Gravity .....	42
Figure 8	Examples of Manifolds for Chemical Tubes. Your equipment can look different .....	42
Figure 9	A Configuration that Prevents Flow in the Machine When the Pump is Off (if the chemical tube and tank have no pressure) .....	43
Figure 10	Peristaltic Diagram .....	78
Figure 11	Peristaltic Inlet .....	79

## Tables

Table 1	Trademarks .....	7
Table 2	Parts List—Safety Placards MWF18J8; MWF27J8/Z8; MWF36J8/Z8; MWF45J8/Z8; MWF63J7/Z7; MWF77J7/Z7 .....	18
Table 3	Parts List—Safety Placards ISO MWF18J8; MWF27J8/Z8; MWF36J8/Z8; MWF45J8/ Z8; MWF63J7/Z7; MWF77J7/Z7 .....	21
Table 4	Parts List—Covers MWF63J7, MWF63Z7, MWF77J7, MWF77Z7 .....	24
Table 5	Parts List—Shipping Brackets MWF36J8, MWF36Z8; MWF45J8, MWF45Z8; MWF63J7, MWF63Z7; MWF77J7, MWF77Z7 .....	27
Table 6	Torque Values for Standard Fasteners with Maximum 5/16-inch Diameters and No Lubricant .....	28

Table 7	Torque Values for Standard Fasteners Larger Than 5/16-inch Diameters and No Lubricant .....	29
Table 8	Torque Values for Plated Fasteners with Maximum 5/16-inch Diameters and No Lubricant .....	29
Table 9	Torque Values for Plated Fasteners Larger Than 5/16-inch Diameters and No Lubricant .....	30
Table 10	Threadlocker by the Diameter of the Bolt (see below Note ) .....	30
Table 11	Torque Values if You Apply LocTite 222 .....	31
Table 12	Torque Values if You Apply LocTite 242 .....	31
Table 13	Torque Values if You Apply LocTite 262 .....	31
Table 14	Torque Values if You Apply LocTite 272 (High-Temperature) .....	31
Table 15	Torque Values if You Apply LocTite 277 .....	32
Table 16	Torque Values for Stainless Steel Fasteners 5/16-inch and Smaller .....	32
Table 17	Torque Values for Stainless Steel Fasteners Larger Than 5/16-inch .....	33
Table 18	Parts List—Drive MWF63J7, MWF63Z7, MWF77J7, MWF77Z7, MWF63C7, MWF63Y7, MWF77C7, MWF77Y7 .....	55
Table 19	Bearing Assembly & Installation MWF45, MWF63, MWF77 .....	60
Table 20	Parts List—Suspension MWF63J7, MWF63Z7, MWF77J7, MWF77Z7, MWF63C7, MWF63Y7, MWF77C7, MWF77Y7 .....	65
Table 21	Parts List—Shocks MWF63J8, MWF63Z8, MWF77J8, MWF77Z8 .....	67
Table 22	Parts List—Installation 26” Door MWF63J7, MWF63Z7, MWF77J7, MWF77Z7, MWF63C7, MWF63Y7, MWF77C7, MWF77Y7 .....	73
Table 23	Parts List—Door Latch MWF36J8, MWF36Z8; MWF45J8, MWF45Z8; MWF63J7, MWF63Z7; MWF77J7, MWF77Z7; MWF63C7, MWF63Y7; MWF77C7, MWF77Y7 .....	74
Table 24	Parts List—Soap Chute MWF36J8, MWF36Z8; MWF45J8, MWF45Z8; MWF63J7, MWF63Z7; MWF77J7, MWF77Z7; MWF63C7, MWF63Y7; MWF77C7, MWF77Y7 .....	77
Table 25	Parts List—Peristaltic Supply MWF36J8, MWF36Z8; MWF45J8, MWF45Z8; MWF63J7, MWF63Z7; MWF77J7, MWF77Z7; MWF63C7, MWF63Y7; MWF77C7, MWF77Y7 .....	79
Table 26	Parts List—5 Compartment Supply MWF36J8, MWF36Z8; MWF45J8, MWF45Z8; MWF63J7, MWF63Z7; MWF77J7, MWF77Z7; MWF63C7, MWF63Y7; MWF77C7, MWF77Y7 .....	81
Table 27	Parts List—Water & Steam MWF63J7, MWF63Z7, MWF63C7, MWF63Y7, MWF77J7, MWF77Z7, MWF77C7, MWF77Y7 .....	85
Table 28	Parts List—Drain Valve to Rear MWF36J8, MWF36Z8; MWF45J8, MWF45Z8; MWF63J7, MWF63Z7; MWF77J7, MWF77Z7 .....	86
Table 29	Parts List—Pneumatic Schematic MWF63J7, MWF63Z7, MWF77J7, MWF77Z7 .....	89
Table 30	Parts List—Water Level & Temperature Sensor MWF45J8/Z8, MWF63J7/Z7, MWF77J7/Z7, MWF100J7/Z7, MWF125J7/Z7; MWF45C8/Y8, MWF63C7/Y7, MWF77C7/Y7, MWF100C7/Y7, MWF125C7/Y7 .....	91

# 1 General Service and Safety Related Components

## **PELLERIN MILNOR CORPORATION LIMITED STANDARD WARRANTY**

We warrant to the original purchaser that MILNOR machines including electronic hardware/software (hereafter referred to as "equipment"), will be free from defects in material and workmanship for a period of one year from the date of shipment (unless the time period is specifically extended for certain parts pursuant to a specific MILNOR published extended warranty) from our factory with no operating hour limitation. This warranty is contingent upon the equipment being installed, operated and serviced as specified in the operating manual supplied with the equipment, and operated under normal conditions by competent operators.

Providing we receive written notification of a warranted defect within 30 days of its discovery, we will—at our option—repair or replace the defective part or parts, EX Factory (labor and freight specifically NOT included). We retain the right to require inspection of the parts claimed defective in our factory prior to repairing or replacing same. We will not be responsible, or in any way liable, for unauthorized repairs or service to our equipment, and this warranty shall be void if the equipment is tampered with, modified, or abused, used for purposes not intended in the design and construction of the machine, or is repaired or altered in any way without MILNOR's written consent.

Parts damaged by exposure to weather, to aggressive water, or to chemical attack are not covered by this warranty. For parts which require routine replacement due to normal wear—such as gaskets, contact points, brake and clutch linings, belts, hoses, and similar parts—the warranty time period is 90 days.

We reserve the right to make changes in the design and/or construction of our equipment (including purchased components) without obligation to change any equipment previously supplied.

ANY SALE OR FURNISHING OF ANY EQUIPMENT BY MILNOR IS MADE ONLY UPON THE EXPRESS UNDERSTANDING THAT MILNOR MAKES NO EXPRESSED OR IMPLIED WARRANTIES OF MERCHANTABILITY OR FITNESS FOR ANY PARTICULAR USE OR PURPOSE OR ANY OTHER WARRANTY IMPLIED BY LAW INCLUDING BUT NOT LIMITED TO REDHIBITION. MILNOR WILL NOT BE RESPONSIBLE FOR ANY COSTS OR DAMAGES ACTUALLY INCURRED OR REQUIRED AS A RESULT OF: THE FAILURE OF ANY OTHER PERSON OR ENTITY TO PERFORM ITS RESPONSIBILITIES, FIRE OR OTHER HAZARD, ACCIDENT, IMPROPER STORAGE, MIS-USE, NEGLIGENCE, POWER OR ENVIRONMENTAL CONTROL MALFUNCTIONS, DAMAGE FROM LIQUIDS, OR ANY OTHER CAUSE BEYOND THE NORMAL RANGE OF USE. REGARDLESS OF HOW CAUSED, IN NO EVENT SHALL MILNOR BE LIABLE FOR SPECIAL, INDIRECT, PUNITIVE, LIQUIDATED, OR CONSEQUENTIAL COSTS OR DAMAGES, OR ANY COSTS OR DAMAGES WHATSOEVER WHICH EXCEED THE PRICE PAID TO MILNOR FOR THE EQUIPMENT IT SELLS OR FURNISHES.

THE PROVISIONS ON THIS PAGE REPRESENT THE ONLY WARRANTY FROM MILNOR AND NO OTHER WARRANTY OR CONDITIONS, STATUTORY OR OTHERWISE, SHALL BE IMPLIED.

WE NEITHER ASSUME, NOR AUTHORIZE ANY EMPLOYEE OR OTHER PERSON TO ASSUME FOR US, ANY OTHER RESPONSIBILITY AND/OR LIABILITY IN CONNECTION WITH THE SALE OR FURNISHING OF OUR EQUIPMENT TO ANY BUYER.

BMP720097/19036



**BNUUUM01 / 2019342**

BNUUUM01 0000250121 B.3 1/2/20, 2:14 PM Released

## 1.1 How to Get the Necessary Repair Components

BNUUUM01.C01 0000250120 G.2 B.3 A.3 1/2/20, 2:14 PM Released

You can get components to repair your machine from the approved supplier where you got this machine. Your supplier will usually have the necessary components in stock. You can also get components from the Milnor® factory.

Tell the supplier the machine model and serial number and this data for each necessary component:

- The component number from this manual
- The component name if known
- The necessary quantity
- The necessary transportation requirements
- If the component is an electrical component, give the schematic number if known.
- If the component is a motor or an electrical control, give the nameplate data from the used component.

To write to the Milnor® factory:

Pellerin Milnor Corporation  
 Post Office Box 400  
 Kenner, LA 70063-0400  
 UNITED STATES

Telephone: 504-712-7775

Fax: 504-469-9777

Email: parts@milnor.com

**BNUUUU02 / 2023296**

BNUUUU02 0000158094 7/20/23, 10:58 AM Released

## 1.2 Trademarks

BNUUUU02.R01 0000158093 G.2 F.2 7/20/23, 10:57 AM Released

These words are trademarks of Pellerin Milnor® Corporation and other entities:

**Table 1. Trademarks**

AutoSpot™	GreenFlex™	MilMetrix®	PulseFlow®
CBW®	GearTrace™	MilTouch™	RAM Command™
Drynet™	GreenTurn™	MilTouch-EX™	RecircONE®
E-P Express®	Hydro-cushion™	MilRAIL®	RinSave®
E-P OneTouch®	Mentor®	Miltrac™	SmoothCoil™

**Table 1 Trademarks (cont'd.)**

E-P Plus®	Mildata®	MilVision™	Staph Guard®
Gear Guardian®	Milnor®	PBW™	

BNWSUS08 / 21224 BNWSUS08 0000348933 A.2 5/26/21, 12:00 PM Released

## 1.3 Safety — Suspended Washer Extractors

BNWSUS08.C01 0000348932 G.2 A.2 5/26/21, 11:48 AM Released

### 1.3.1 Safety Alert Messages—Internal Electrical and Mechanical Hazards

BNWSUS01.C03 0000234965 G.2 A.2 A.4 1/2/20, 2:19 PM Released

The following are instructions about hazards inside the machine and in electrical enclosures.



**WARNING: Electrocutation and Electrical Burn Hazards** — Contact with electric power can kill or seriously injure you. Electric power is present inside the cabinetry unless the main machine power disconnect is off.

- ▶ Do not unlock or open electric box doors.
- ▶ Do not remove guards, covers, or panels.
- ▶ Do not reach into the machine housing or frame.
- ▶ Keep yourself and others off of machine.
- ▶ Know the location of the main machine disconnect and use it in an emergency to remove all electric power from the machine.



**WARNING: Entangle and Crush Hazards** — Contact with moving components normally isolated by guards, covers, and panels, can entangle and crush your limbs. These components move automatically.

- ▶ Do not remove guards, covers, or panels.
- ▶ Do not reach into the machine housing or frame.
- ▶ Keep yourself and others off of machine.
- ▶ Know the location of all emergency stop switches, pull cords, and/or kick plates and use them in an emergency to stop machine motion.

### 1.3.2 Safety Alert Messages—Cylinder and Processing Hazards

BNWSUS03.C03 0000234973 G.2 A.2 A.3 1/2/20, 2:19 PM Released

The following are instructions about hazards related to the cylinder and laundering process.



**DANGER: Entangle and Sever Hazards** — Contact with goods being processed can cause the goods to wrap around your body or limbs and dismember you. The goods are normally isolated by the locked cylinder door.

- ▶ Do not attempt to open the door or reach into the cylinder until the cylinder is stopped.
- ▶ Do not touch goods inside or hanging partially outside the turning cylinder.
- ▶ Do not operate the machine with a malfunctioning door interlock.
- ▶ Open pocket machines only—Do not jog the cylinder and pull the goods at the same time.
- ▶ Open pocket machines only—Keep yourself and others clear of cylinder and goods during jogging operation.
- ▶ Do not operate the machine with malfunctioning two-hand manual controls.
- ▶ Know the location of all emergency stop switches, pull cords, and/or kick plates and use them in an emergency to stop machine motion.
- ▶ Know the location of the main machine disconnect and use it in an emergency to remove all electric power from the machine.



**WARNING: Crush Hazards** — Contact with the turning cylinder can crush your limbs. The cylinder will repel any object you try to stop it with, possibly causing the object to strike or stab you. The turning cylinder is normally isolated by the locked cylinder door.

- ▶ Do not attempt to open the door or reach into the cylinder until the cylinder is stopped.
- ▶ Do not place any object in the turning cylinder.
- ▶ Do not operate the machine with a malfunctioning door interlock.
- ▶ Open pocket machines only—Keep yourself and others clear of cylinder and goods during jogging operation.
- ▶ Do not operate the machine with malfunctioning two-hand manual controls.



**WARNING: Confined Space Hazards** — Confinement in the cylinder can kill or injure you. Hazards include but are not limited to panic, burns, poisoning, suffocation, heat prostration, biological contamination, electrocution, and crushing.

- ▶ Do not attempt unauthorized servicing, repairs, or modification.



**WARNING: Explosion and Fire Hazards** — Flammable substances can explode or ignite in the cylinder, drain trough, or sewer. The machine is designed for washing with water, not any other solvent. Processing can cause solvent-containing goods to give off flammable vapors.

- ▶ Do not use flammable solvents in processing.
- ▶ Do not process goods containing flammable substances. Consult with your local fire department/public safety office and all insurance providers.

### 1.3.3 Safety Alert Messages—Unsafe Conditions

BNWSUS04.C01 0000235002 G.2 A.2 A.3 12/10/20, 4:36 PM Released

#### 1.3.3.1 Damage and Malfunction Hazards

BNWSUS04.C02 0000235001 G.2 A.2 A.3 12/10/20, 4:36 PM Released

##### 1.3.3.1.1 Hazards Resulting from Inoperative Safety Devices

BNWSUS04.C03 0000235000 G.2 A.2 A.6 12/10/20, 4:36 PM Released



**DANGER: Entangle and Sever Hazards** — Cylinder door interlock— Operating the machine with a malfunctioning door interlock can permit opening the door when the cylinder is turning and/or starting the cycle with the door open, exposing the turning cylinder.

- ▶ Do not operate the machine with any evidence of damage or malfunction.



**WARNING: Multiple Hazards** — Operating the machine with an inoperative safety device can kill or injure personnel, damage or destroy the machine, damage property, and/or void the warranty.

- ▶ Do not tamper with or disable any safety device or operate the machine with a malfunctioning safety device. Request authorized service.

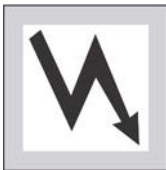

**WARNING: Electrocution and Electrical Burn Hazards** — Electric box doors—Operating the machine with any electric box door unlocked can expose high voltage conductors inside the box.

- ▶ Do not unlock or open electric box doors.



**WARNING: Entangle and Crush Hazards** — Guards, covers, and panels—Operating the machine with any guard, cover, or panel removed exposes moving components.

- ▶ Do not remove guards, covers, or panels.

##### 1.3.3.1.2 Hazards Resulting from Damaged Mechanical Devices

BNWSUS04.C04 0000234999 G.2 A.2 A.4 12/10/20, 4:36 PM Released



**WARNING: Multiple Hazards** — Operating a damaged machine can kill or injure personnel, further damage or destroy the machine, damage property, and/or void the warranty.

- ▶ Do not operate a damaged or malfunctioning machine. Request authorized service.



**WARNING: Explosion Hazards** — Cylinder—A damaged cylinder can rip apart during extraction, puncturing the shell and discharging metal fragments at high speed.

- ▶ Do not operate the machine with any evidence of damage or malfunction.



**WARNING: Explosion Hazards** — Clutch and speed switch (multiple motor machines)—A damaged clutch or speed switch can permit the low speed motor to engage during extract. This will over-speed the motor and pulleys and can cause them to rip apart, discharging metal fragments at high speed.

- ▶ Stop the machine immediately if any of these conditions occur: • abnormal whining sound during extract • skidding sound as extract ends • clutches remain engaged or re-engage during extract

### 1.3.3.2 Careless Use Hazards

BNWSUS04.C05 0000234998 G.2 A.2 A.3 12/10/20, 4:36 PM Released

#### 1.3.3.2.1 Careless Operation Hazards—Vital Information for Operator Personnel (see also operator hazards throughout manual)

BNWSUS04.C06 0000234997 G.2 A.2 A.4 12/10/20, 4:36 PM Released



**WARNING: Multiple Hazards** — Careless operator actions can kill or injure personnel, damage or destroy the machine, damage property, and/or void the warranty.

- ▶ Do not tamper with or disable any safety device or operate the machine with a malfunctioning safety device. Request authorized service.
- ▶ Do not operate a damaged or malfunctioning machine. Request authorized service.
- ▶ Do not attempt unauthorized servicing, repairs, or modification.
- ▶ Do not use the machine in any manner contrary to the factory instructions.
- ▶ Use the machine only for its customary and intended purpose.
- ▶ Understand the consequences of operating manually.

#### 1.3.3.2.2 Careless Servicing Hazards—Vital Information for Service Personnel (see also service hazards throughout manuals)

BNWSUS04.C07 0000234996 G.2 A.2 A.4 12/10/20, 4:36 PM Released

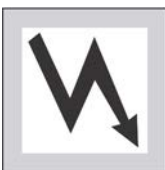

**WARNING: Electrocution and Electrical Burn Hazards** — Contact with electric power can kill or seriously injure you. Electric power is present inside the cabinetry unless the main machine power disconnect is off.

- ▶ Do not service the machine unless qualified and authorized. You must clearly understand the hazards and how to avoid them.

- ▶ Abide by the current OSHA lockout/tagout standard when lockout/tagout is called for in the service instructions. Outside the USA, abide by the OSHA standard in the absence of any other overriding standard.



**WARNING: Entangle and Crush Hazards** — Contact with moving components normally isolated by guards, covers, and panels, can entangle and crush your limbs. These components move automatically.

- ▶ Do not service the machine unless qualified and authorized. You must clearly understand the hazards and how to avoid them.
- ▶ Abide by the current OSHA lockout/tagout standard when lockout/tagout is called for in the service instructions. Outside the USA, abide by the OSHA standard in the absence of any other overriding standard.



**WARNING: Confined Space Hazards** — Confinement in the cylinder can kill or injure you. Hazards include but are not limited to panic, burns, poisoning, suffocation, heat prostration, biological contamination, electrocution, and crushing.

- ▶ Do not enter the cylinder until it has been thoroughly purged, flushed, drained, cooled, and immobilized.

## 1.4 Installation Tag Guidelines

BNWMAI01.R01 0000204673 G.2 C.2 D.2 5/31/23, 9:24 AM Released

MWF27J8	MWF27Z8	MWF36J8	MWF36Z8
MWF45J8	MWF45Z8	MWF63C7	MWF63J7
MWF63Y7	MWF63Z7	MWF77C7	MWF77J7
MWF77Y7	MWF77Z7	MWF100C7	MWF100J7
MWF100Y7	MWF100Z7	MWF125C7	MWF125J7
MWF125Y7	MWF125Z7		

**NOTICE:** This information may apply to models in addition to those listed above. It applies to paper tags. It does not apply to the vinyl or metal safety placards, which must remain permanently affixed to the machine and replaced if no longer readable.

Paper tags on the machine provide installation guidelines and precautions. The tags can be tie-on or adhesive. You can remove tie-on tags and white, adhesive tags after installation. Yellow adhesive tags must remain on the machine.

The following entries explain the installation tags. Each entry includes: 1) the tag illustration, 2) the tag part number at the bottom of the tag, and 3) the meaning of the tag.

**Display or Action**

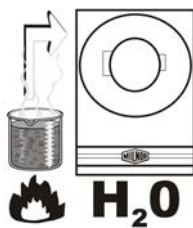
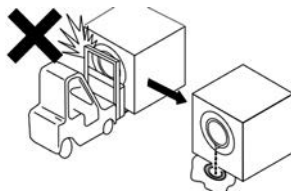

**Explanation**

Read the manuals before proceeding. This symbol appears on most tags. The machine ships with safety, operator, and routine maintenance guides for customer use. Milnor dealer manuals for installing, commissioning, and servicing the machine are also available from the Milnor Parts department.

B2TAG88005: This carefully built product was tested and inspected to meet Milnor performance and quality standards by (identification mark of tester).

B2TAG94078: Do not forklift here; do not jack here; do not step here—whichever applies.

B2TAG94081: Motor must rotate in this direction. On single motor washer-extractors and centrifugal extractors, the drive motor must turn in this direction during draining and extraction. This tag is usually wrapped around a motor housing. If the motor turns in the opposite direction when the machine is first tested, the electrical hookup is incorrect and must be reversed as explained in the schematic manual.

B2TAG94097: The cylinder must rotate **counterclockwise** during draining and extraction (spin) when viewed from here (rear of machine). Otherwise, reverse the electric power connections, as explained in the schematic manual.

B2TAG94099: Do not strike the shell door when fork-lifting. This can cause the door to leak.

B2T2001013: Hot water connection.



B2T2001014: Cold water connection.



B2T2001015: Reuse (third) water connection.

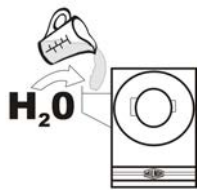

B2T2001016: Flushing water connection. This is the water that goes into the supply compartment or pumped chemical manifold to flush chemicals into the machine.

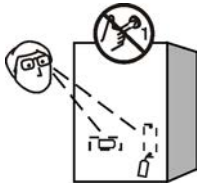

B2T2001028: Look for tags inside the machine. These tags may identify shipping restraints to be removed or components to be installed. Do not start the machine until these actions are completed.



B2T2002013: Do not start the machine until shipping restraints are removed. This tag will appear on the outside of the machine to alert you to the presence of internal shipping restraints. A tag will also appear on the restraint to help identify it. Most, but not all shipping restraints display the color red. Some shipping restraints are also safety stands. Do not discard these.

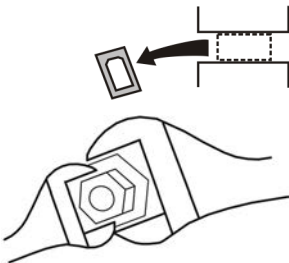

B2T2003001: Hold the side of the connection stationary with a wrench as you tighten the connection with another wrench. Otherwise, you may twist components, such as valves, damaging them.



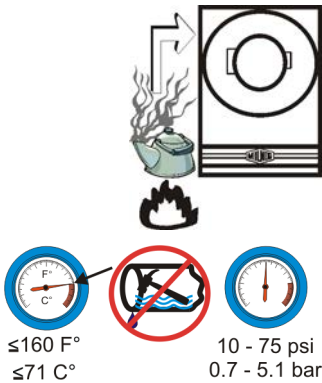

B2T2004027: Steam connection.

B2T2008007: Do not exceed 160° Fahrenheit (71° Celsius) water temperature. Excessive temperature can damage the water valves in this machine. Eliminate water hammer on the water lines to this machine. Water hammer can rupture the water inlet valves on this machine. Follow applicable codes when installing water hammer arresters. Maintain incoming water pressure between 10 and 75 psi (between 0.7 and 5.1 bar). Pressures outside this range can damage the water valves in this machine.

Safety Placards and Locations

MWF18J8; MWF27J8/Z8; MWF36J8/Z8; MWF45J8/Z8; MWF63J7/Z7; MWF77J7/Z7



**NOTICE:** Replace placard immediately, if removed or unreadable. Approximate locations of placards are shown. If aluminum placard, mounting holes are provided on machine. Use #8 self-tapping screws.

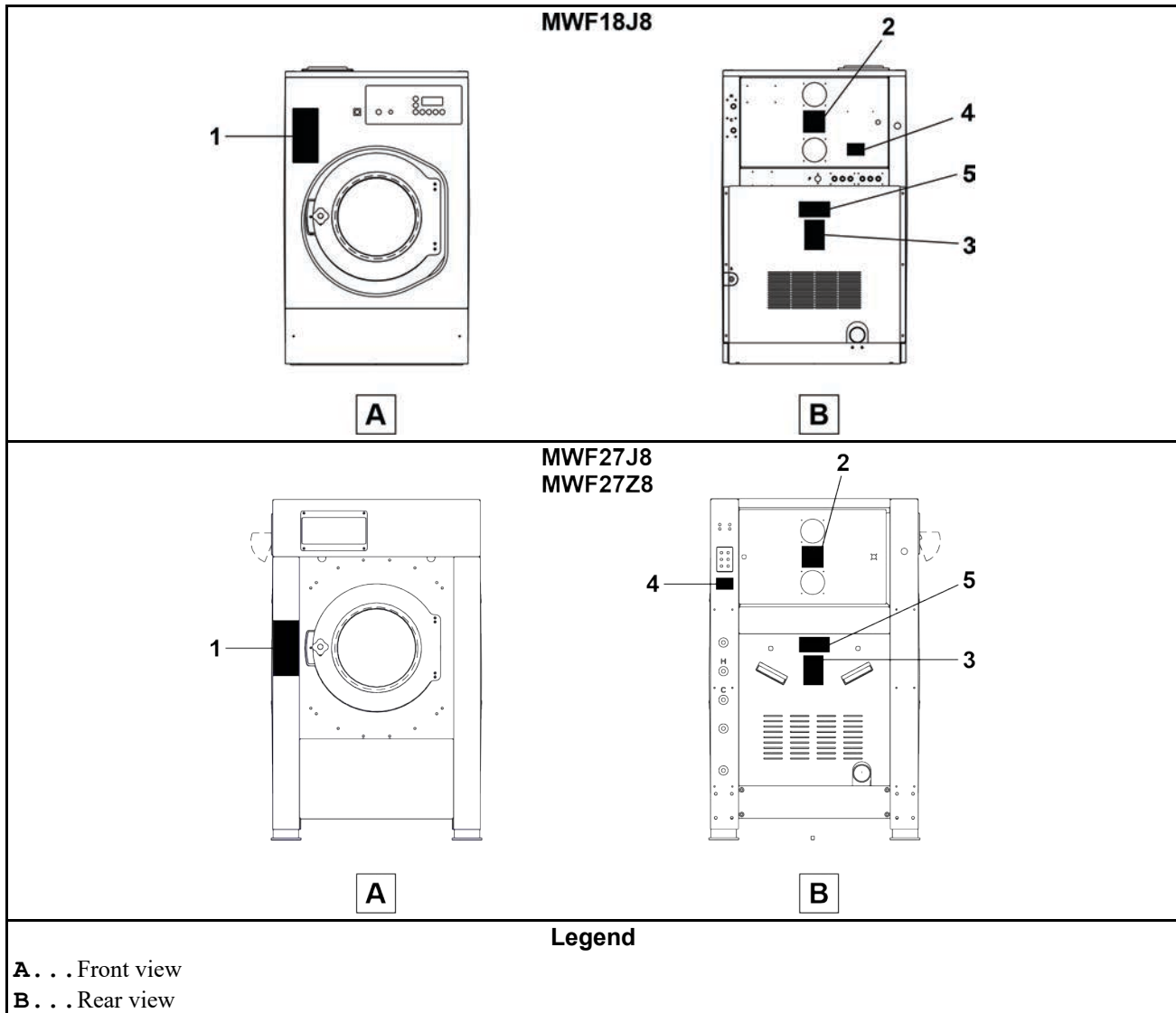

**Safety Placards and Locations**

3 Sheet

MWF18J8; MWF27J8/Z8; MWF36J8/Z8; MWF45J8/Z8; MWF63J7/Z7; MWF77J7/Z7

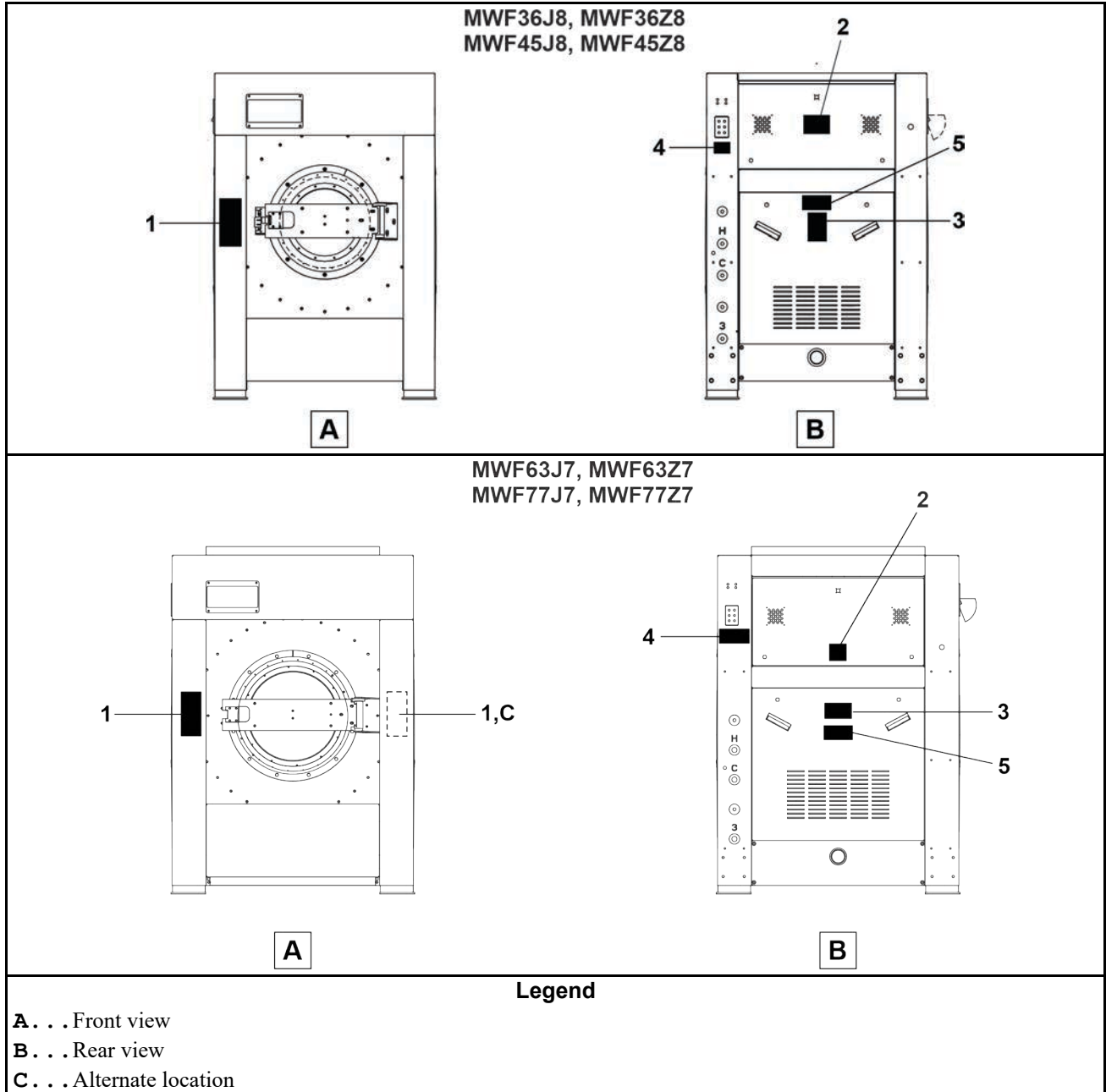

## Safety Placards and Locations

3 Sheet

MWF18J8; MWF27J8/Z8; MWF36J8/Z8; MWF45J8/Z8; MWF63J7/Z7; MWF77J7/Z7

**Table 2. Parts List—Safety Placards**

Find the assembly for your machine and the letter shown in the "Item" column. The components for your machine will show this letter or the word "all" in the "Used In" column. The numbers shown in the "Item" column are those shown in the illustrations.				
Used In	Item	Part Number	Description/Nomenclature	Comments
Components				
all	1	01 10631B	NMPLT:SHELLFNT WARN MWF->TACATA	
all	2	01 10377A	NPLT:ELEC HAZARD LG-TCATA	
all	3	01 10699A	NPLT:SERV HZRD-PLYEST-TCATA	
all	4	01 10710A	NPLT:CAUTION CHEMICAL SYSTEM	
all	5	01 10689A	NPLT:BELT HAZARD SM TCATA	

BPWMYM03 / 2022383A

BPWMYM03.1 0000348807 G.2 D.2 9/19/22, 5:13 PM Released

## Safety Placards and Locations ISO

3 Sheet

MWF18J8; MWF27J8/Z8; MWF36J8/Z8; MWF45J8/Z8; MWF63J7/Z7; MWF77J7/Z7



**NOTICE:** Replace placard immediately, if removed or unreadable. Approximate locations of placards are shown. If aluminum placard, mounting holes are provided on machine. Use #8 self-tapping screws.

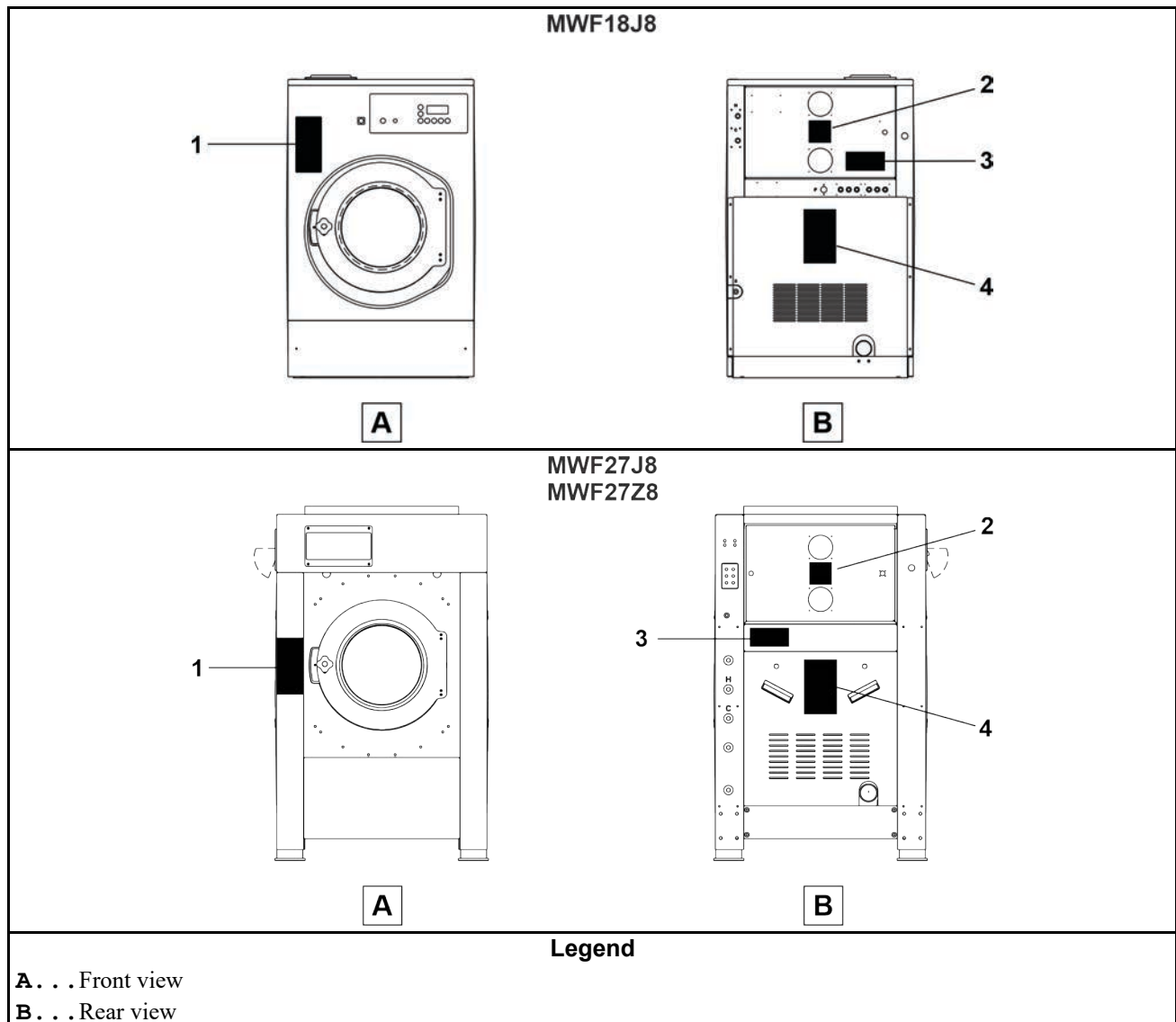

### Safety Placards and Locations ISO

MWF18J8; MWF27J8/Z8; MWF36J8/Z8; MWF45J8/Z8; MWF63J7/Z7; MWF77J7/Z7

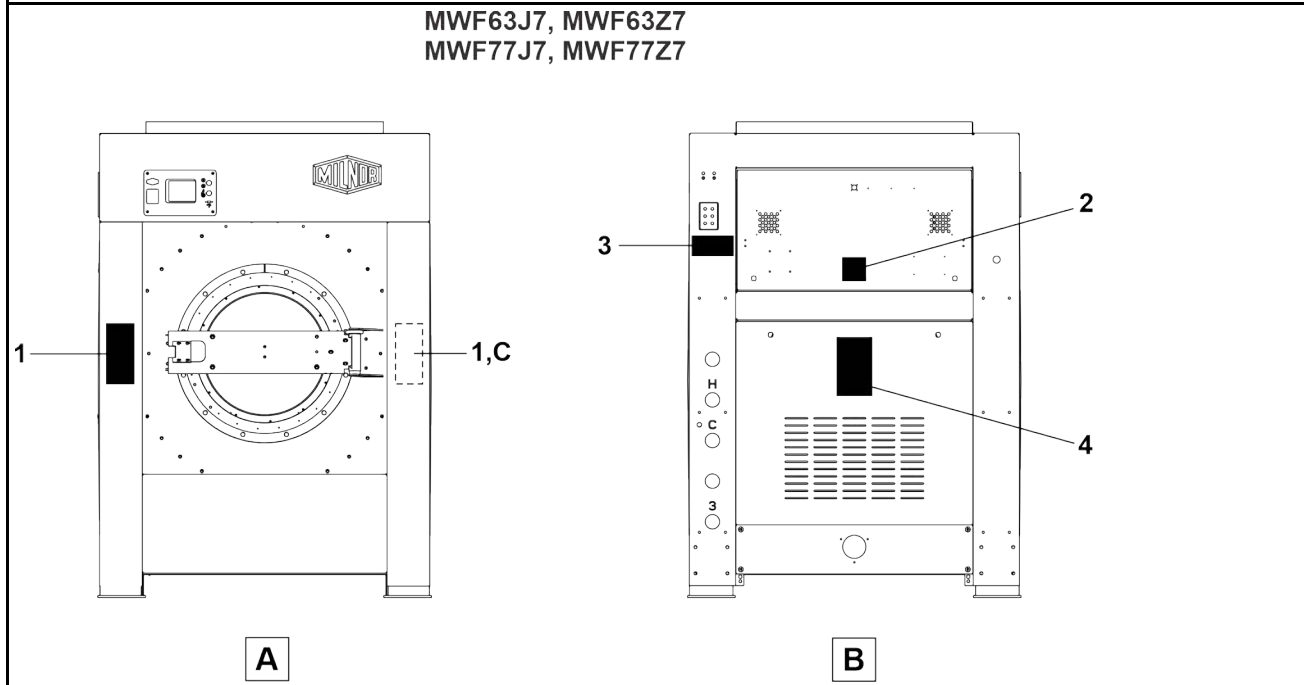
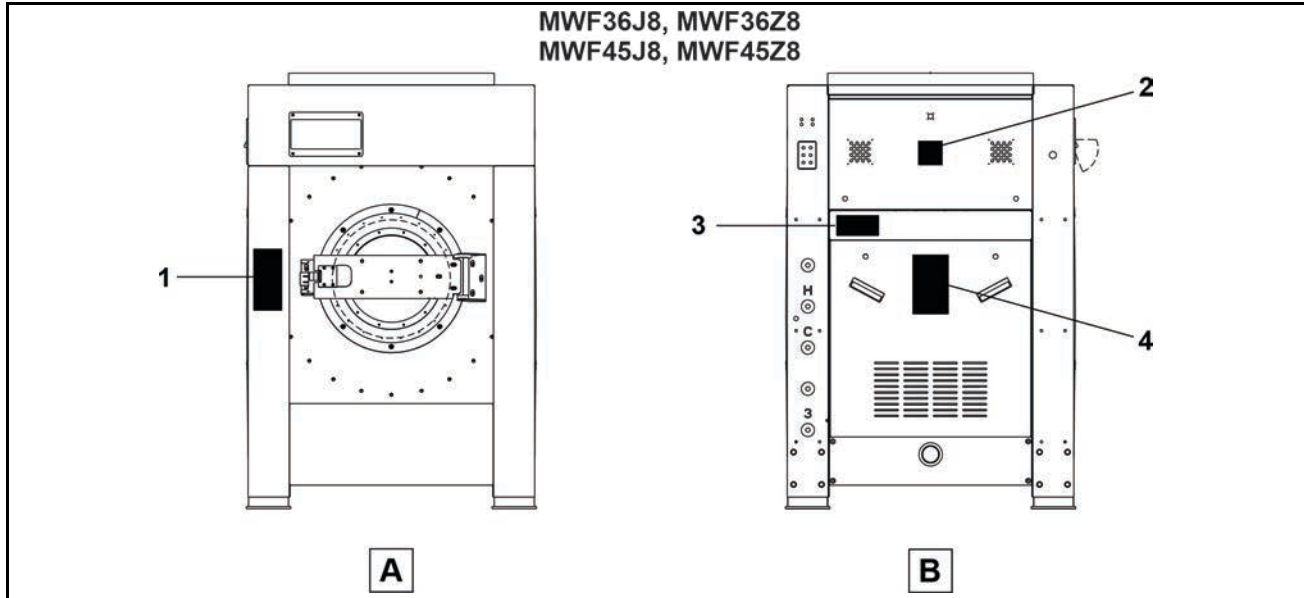

**Legend**

- A** . . . Front view
- B** . . . Rear view
- C** . . . Alternate location

## Safety Placards and Locations ISO

3 Sheet

MWF18J8; MWF27J8/Z8; MWF36J8/Z8; MWF45J8/Z8; MWF63J7/Z7; MWF77J7/Z7

**Table 3. Parts List—Safety Placards ISO**

Find the assembly for your machine and the letter shown in the "Item" column. The components for your machine will show this letter or the word "all" in the "Used In" column. The numbers shown in the "Item" column are those shown in the illustrations.				
Used In	Item	Part Number	Description/Nomenclature	Comments
Components				
all	1	01 10631Y	NPLT:SHELL FRT WARN NOTILT-ISO	
all	2	01 10377	NPLTE:"WARNING" 4X4	
all	3	01 10710A	NPLT:CAUTION CHEMICAL SYSTEM	
all	4	01 10628X	NPLT:NONTILT W/E WARNING SIDE	

BPWMCM01 / 2022182

BPWMCM01.1 0000417569 G.2 A.4 4/25/22, 2:26 PM Released

**Covers**

3 Sheets

MWF63J7, MWF63Z7, MWF77J7, MWF77Z7





Covers

3 Sheets

MWF63J7, MWF63Z7, MWF77J7, MWF77Z7



**Covers**

3 Sheets

MWF63J7, MWF63Z7, MWF77J7, MWF77Z7

**Table 4. Parts List—Covers**

Find the assembly for your machine and the letter shown in the "Item" column. The components for your machine will show this letter or the word "all" in the "Used In" column. The numbers shown in the "Item" column are those shown in the illustrations.				
Used In	Item	Part Number	Description/Nomenclature	Comments
Reference Assemblies				
	A		MWF63J7, MWF63Z7	
	B		MWF77J7, MWF77Z7	
Components				
A	1	98MW23069	COVER, TOP MWF63	
B	1	98MW21069	COSM TOP=MWF77	
A	2	98MW23076	COVER, SIDE MWF63	
B	2	98MW21076	COSM=SIDE DOOR, MWF77	
all	3	98MW21082	COSM REAR MWF77	

This page intentionally blank

BPWM2K01 / 2022354

BPWM2K01.1 0000410093 G.2 B.2 8/24/22, 5:45 PM Released

## Shipping Brackets

2 Sheets

MWF36J8, MWF36Z8; MWF45J8, MWF45Z8; MWF63J7, MWF63Z7; MWF77J7, MWF77Z7.



**NOTE:** Before operating, remove the shipping brackets (painted red). The shipping brackets may be retained in the event the machine must be moved. See BNWUUI03.

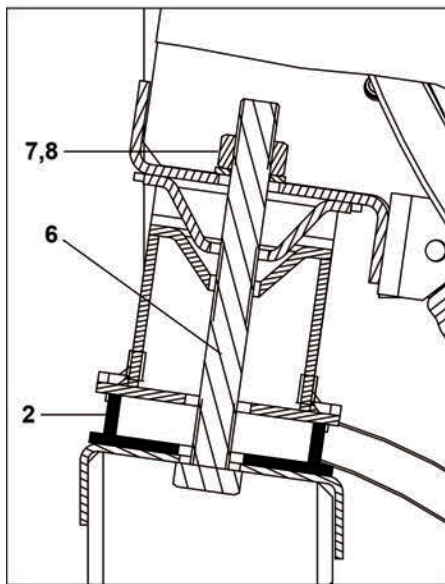
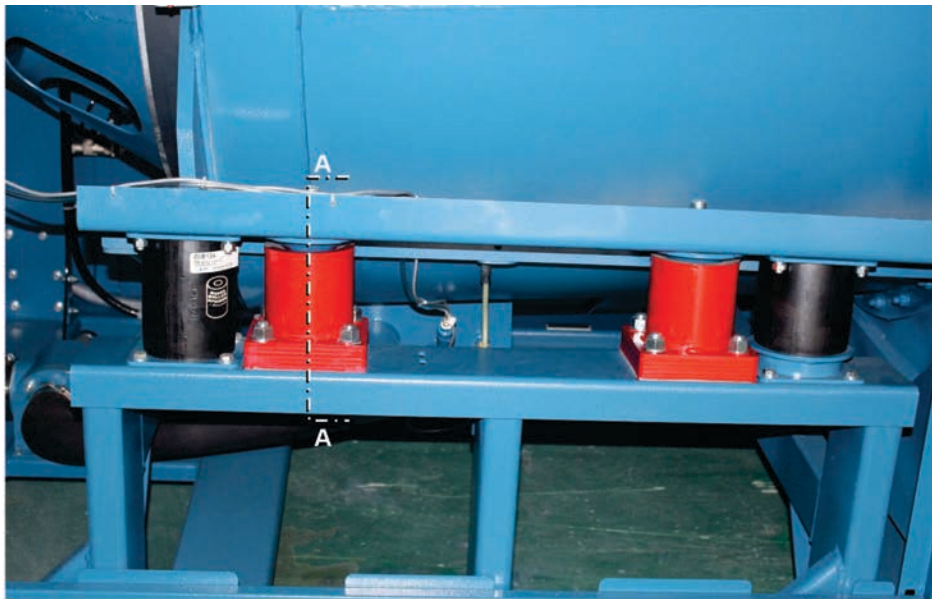

A-A

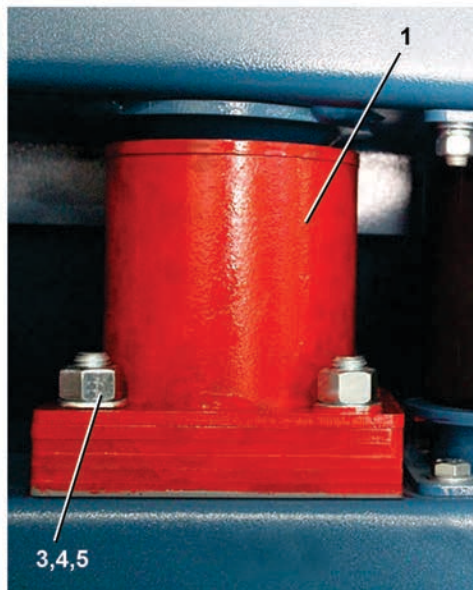

### Legend

Ā-Ā . . Typical 4 instances

## Shipping Brackets

2 Sheets

MWF36J8, MWF36Z8; MWF45J8, MWF45Z8; MWF63J7, MWF63Z7; MWF77J7, MWF77Z7.

**Table 5. Parts List—Shipping Brackets**

Find the assembly for your machine and the letter shown in the "Item" column. The components for your machine will show this letter or the word "all" in the "Used In" column. The numbers shown in the "Item" column are those shown in the illustrations.				
Used In	Item	Part Number	Description/Nomenclature	Comments
Reference Assemblies				
	A	MWF45	REFERENCE	
	B	MWF63	REFERENCE	
	C	MWF77	REFERENCE	
Components				
A	1	98MW489198	SHIPPING BRACKET MWF45	
B	1	98MW489260	SHIPPING BRACKET MWF63	
C	1	W3 25161A	PLATE=HOLD DOWN RING WLMT	
AB	2	98MW919802	SHIM=SHIPPING BRACKET, MWF63	
C	2	03 06406D	PLATE-HOLD DOWN RING-TOP	
AB	3	98CX770144	HEXCAPSCR M12X65, ZINC8.8	
C	3	98CX770164	HEXCAPSCR M16X70, ZINC8.8	
AB	4	98CX773113	HEXNUTM12, ZINC	
C	4	98CX773115	HEXNUT M16, ZINC	
AB	5	98CX773513	FLATWASHER, D12 ZINC	
C	5	98CX773515	FLATWASHER, D16 ZINC	
A	6	98CX772272J	HEXCAPSCR M24X190, ZINC8.8	
BC	6	98CX770202	HEXCAPSCR M24X230, ZINC8.8	
ABC	7	98CX7735175	FLATWASHER, D24 ZINC	
ABC	8	98CX773224	HEXNUT M24, ZINC	

## 1.5 Torque Requirements for Fasteners

BNUUUN02.C01 0000222451 G.2 B.3 A.3 1/2/20, 2:14 PM Released

The document about the assembly gives the torque requirements for other fasteners. **If fastener torque specifications or threadlocker requirements in an assembly document are different from this document, use the assembly document.**

**Figure 1. The Bolts in Milnor® Equipment**

The Marks on Bolt Heads	Legend
	<p><b>A</b> . . . SAE Grades 1 and 2, ASTM A307, and stainless steel</p> <p><b>B</b> . . . Grade BC, ASTM A354</p> <p><b>C</b> . . . SAE Grade 5, ASTM A449</p> <p><b>D</b> . . . SAE Grade 8 and ASTM A354 BD</p>

### 1.5.1 Torque Values

BNUUUN02.C02 0000222449 G.2 B.3 A.3 1/2/20, 2:14 PM Released

These tables give the standard dimension, grade, threadlocker, and torque requirements for fasteners frequently used on Milnor® equipment.



**NOTE:** Data from the Pellerin Milnor® Corporation “Bolt Torque Specification” (bolt\_torque\_milnor.xls/2002096).

#### 1.5.1.1 Fasteners Made of Carbon Steel

BNUUUN02.C03 0000222448 G.2 B.3 A.3 1/2/20, 2:14 PM Released

##### 1.5.1.1.1 Without a Threadlocker

BNUUUN02.C04 0000222447 G.2 B.3 A.3 1/2/20, 2:14 PM Released

**Table 6. Torque Values for Standard Fasteners with Maximum 5/16-inch Diameters and No Lubricant**

Dimension	The Grade of the Bolt							
	Grade 2		Grade 5		Grade 8		Grade BC	
	Pound-Inches	N-m	Pound-Inches	N-m	Pound-Inches	N-m	Pound-Inches	N-m
1/4 x 20	66	7	101	11	143	16	126	14
1/4 x 28	76	9	116	13	163	18	–	–
5/16 x 18	136	15	209	24	295	33	258	29
5/16 x 24	150	17	232	26	325	37	–	–

**Table 7. Torque Values for Standard Fasteners Larger Than 5/16-inch Diameters and No Lubricant**

Dimension	The Grade of the Bolt							
	Grade 2		Grade 5		Grade 8		Grade BC	
	Pound-Feet	N-m	Pound-Feet	N-m	Pound-Feet	N-m	Pound-Feet	N-m
3/8 x 16	20	27	31	42	44	59	38	52
3/8 x 24	23	31	35	47	50	68	–	–
7/16 x 14	32	43	49	66	70	95	61	83
7/16 x 20	36	49	55	75	78	105	–	–
1/2 x 13	49	66	75	102	107	145	93	126
1/2 x 20	55	75	85	115	120	163	–	–
9/16 x 12	70	95	109	148	154	209	134	182
9/16 x 18	78	106	121	164	171	232	–	–
5/8 x 11	97	131	150	203	212	287	186	252
5/8 x 18	110	149	170	231	240	325	–	–
3/4 x 10	172	233	266	361	376	510	329	446
3/4 x 16	192	261	297	403	420	569	–	–
7/8 x 9	167	226	429	582	606	821	531	719
7/8 x 14	184	249	473	641	668	906	–	–
1 x 8	250	339	644	873	909	1232	796	1079
1 x 12	274	371	704	954	994	1348	–	–
1 x 14	281	381	723	980	1020	1383	–	–
1 1/8 x 7	354	480	794	1077	1287	1745	1126	1527
1 1/8 x 12	397	538	891	1208	1444	1958	–	–
1 1/4 x 7	500	678	1120	1519	1817	2464	1590	2155
1 1/4 x 12	553	750	1241	1682	2012	2728	–	–
1 3/8 x 6	655	888	1469	1992	2382	3230	2085	2827
1 3/8 x 12	746	1011	1672	2267	2712	3677	–	–
1 1/2 x 6	869	1178	1949	2642	3161	4286	2767	3751
1 1/2 x 12	979	1327	2194	2974	3557	4822	–	–

**Table 8. Torque Values for Plated Fasteners with Maximum 5/16-inch Diameters and No Lubricant**

Dimension	The Grade of the Bolt							
	Grade 2		Grade 5		Grade 8		Grade BC	
	Pound-Inches	N-m	Pound-Inches	N-m	Pound-Inches	N-m	Pound-Inches	N-m
1/4 x 20	49	6	76	9	107	12	95	11
1/4 x 28	56	6	88	10	122	14	–	–
5/16 x 18	102	12	156	18	222	25	193	22
5/16 x 24	113	13	174	20	245	28	–	–

**Table 9. Torque Values for Plated Fasteners Larger Than 5/16-inch Diameters and No Lubricant**

Dimension	The Grade of the Bolt							
	Grade 2		Grade 5		Grade 8		Grade BC	
	Pound-Feet	N-m	Pound-Feet	N-m	Pound-Feet	N-m	Pound-Feet	N-m
3/8 x 16	15	20	23	31	33	44	29	38
3/8 x 24	17	23	26	35	37	49	–	–
7/16 x 14	24	32	37	50	52	71	46	61
7/16 x 20	27	36	41	55	58	78	–	–
1/2 x 13	37	49	56	76	80	106	70	93
1/2 x 20	41	55	64	85	90	120	–	–
9/16 x 12	53	70	81	110	115	153	101	134
9/16 x 18	59	79	91	122	128	174	–	–
5/8 x 11	73	97	113	150	159	212	139	186
5/8 x 18	83	110	127	172	180	240	–	–
3/4 x 10	129	173	200	266	282	376	246	329
3/4 x 16	144	192	223	297	315	420	–	–
7/8 x 9	125	166	322	430	455	606	398	531
7/8 x 14	138	184	355	474	501	668	–	–
1 x 8	188	250	483	644	682	909	597	796
1 x 12	205	274	528	716	746	995	–	–
1 x 14	210	280	542	735	765	1037	–	–
1 1/8 x 7	266	354	595	807	966	1288	845	1126
1 1/8 x 12	298	404	668	890	1083	1444	–	–
1 1/4 x 7	375	500	840	1120	1363	1817	1192	1590
1 1/4 x 12	415	553	930	1261	1509	2013	–	–
1 3/8 x 6	491	655	1102	1470	1787	2382	1564	2085
1 3/8 x 12	559	758	1254	1672	2034	2712	–	–
1 1/2 x 6	652	870	1462	1982	2371	3161	2075	2767
1 1/2 x 12	733	994	1645	2194	2668	3557	–	–

**1.5.1.1.2 With a Threadlocker**

BNUUUN02.C05 0000222446 G.2 B.3 A.3 1/2/20, 2:14 PM Released

**Table 10. Threadlocker by the Diameter of the Bolt (see below Note )**

LocTite Product	Dimension			
	1/4-inch	1/4- to 5/8-inch	5/8- to 7/8-inch	1-inch +
LocTite 222	OK			
LocTite 242			OK	
LocTite 262				OK
LocTite 272				High temperature
LocTite 277				OK





**NOTE:** The acceptable bolt size ranges for various LocTite® threadlocking products is the LocTite manufacturer’s **general** recommendation. Specific applications sometime require that a LocTite product is applied to a bolt size outside the ranges shown here. For example, Milnor® specifies LocTite 242 for use on certain 1" bolt applications and has confirmed this usage with the LocTite manufacturer. You may see variances such as this in the documentation for specific machine assemblies.

**Table 11. Torque Values if You Apply LocTite 222**

Dimension	The Grade of the Bolt							
	Grade 2		Grade 5		Grade 8		Grade BC	
	Pound-Inches	N-m	Pound-Inches	N-m	Pound-Inches	N-m	Pound-Inches	N-m
1/4 x 20	60	7	96	11	132	15	108	12
1/4 x 28	72	8	108	12	144	16	–	–

**Table 12. Torque Values if You Apply LocTite 242**

Dimension	The Grade of the Bolt							
	Grade 2		Grade 5		Grade 8		Grade BC	
	Pound-Feet	N-m	Pound-Feet	N-m	Pound-Feet	N-m	Pound-Feet	N-m
5/16 x 18	11	15	17	23	25	34	22	30
5/16 x 24	13	18	19	26	27	37	27	37
3/8 x 16	20	27	31	42	44	60	38	52
3/8 x 24	23	31	35	47	50	68	–	–
7/16 x 14	32	43	49	66	70	95	61	83
7/16 x 20	36	49	55	75	78	106	–	–
1/2 x 13	49	66	75	102	107	145	93	126
1/2 x 20	55	75	85	115	120	163	–	–
9/16 x 12	70	95	109	148	154	209	134	182
9/16 x 18	78	106	121	164	171	232	–	–
5/8 x 11	97	132	150	203	212	287	186	252
5/8 x 18	110	149	170	230	240	325	–	–

**Table 13. Torque Values if You Apply LocTite 262**

Dimension	The Grade of the Bolt							
	Grade 2		Grade 5		Grade 8		Grade BC	
	Pound-Feet	N-m	Pound-Feet	N-m	Pound-Feet	N-m	Pound-Feet	N-m
3/4 x 10	155	210	240	325	338	458	296	401
3/4 x 16	173	235	267	362	378	512	–	–
7/8 x 9	150	203	386	523	546	740	477	647
7/8 x 14	165	224	426	578	601	815	–	–

**Table 14. Torque Values if You Apply LocTite 272 (High-Temperature)**

Dimension	The Grade of the Bolt							
	Grade 2		Grade 5		Grade 8		Grade BC	
	Pound-Feet	N-m	Pound-Feet	N-m	Pound-Feet	N-m	Pound-Feet	N-m
1 x 8	350	475	901	1222	1272	1725	1114	1510
1 x 12	383	519	986	1337	1392	1887	–	–

**Table 14 Torque Values if You Apply LocTite 272 (High-Temperature) (cont'd.)**

Dimension	The Grade of the Bolt							
	Grade 2		Grade 5		Grade 8		Grade BC	
	Pound-Feet	N-m	Pound-Feet	N-m	Pound-Feet	N-m	Pound-Feet	N-m
1 x 14	393	533	1012	1372	1428	1936	–	–
1-1/8 x 7	496	672	1111	1506	1802	2443	1577	2138
1-1/8 x 12	556	754	1247	1691	2022	2741	–	–
1-1/4 x 7	700	949	1568	2126	2544	3449	2226	3018
1-1/4 x 12	774	1049	1737	2355	2816	3818	–	–
1-3/8 x 6	917	1243	2056	2788	3335	4522	2919	3958
1-3/8 x 12	1044	1415	2341	3174	3797	5148	–	–
1-1/2 x 6	1217	1650	2729	3700	4426	6001	3873	5251
1-1/2 x 12	1369	1856	3071	4164	4980	6752	–	–

**Table 15. Torque Values if You Apply LocTite 277**

Dimension	The Grade of the Bolt							
	Grade 2		Grade 5		Grade 8		Grade BC	
	Pound-Feet	N-m	Pound-Feet	N-m	Pound-Feet	N-m	Pound-Feet	N-m
1 x 8	325	441	837	1135	1181	1601	1034	1402
1 x 12	356	483	916	1242	1293	1753	–	–
1 x 14	365	495	939	1273	1326	1798	–	–
1-1/8 x 7	461	625	1032	1399	1674	2270	1464	1985
1-1/8 x 12	516	700	1158	1570	1877	2545	–	–
1-1/4 x 7	650	881	1456	1974	2362	3202	2067	2802
1-1/4 x 12	719	975	1613	2187	2615	3545	–	–
1-3/8 x 6	851	1154	1909	2588	3097	4199	2710	3674
1-3/8 x 12	970	1315	2174	2948	3526	4781	–	–
1-1/2 x 6	1130	1532	2534	3436	4110	5572	3597	4877
1-1/2 x 12	1271	1723	2852	3867	4624	6269	–	–

### 1.5.1.2 Stainless Steel Fasteners

BNUUUN02.C06 0000222445 G.2 B.3 A.3 1/2/20, 2:14 PM Released

**Table 16. Torque Values for Stainless Steel Fasteners 5/16-inch and Smaller**

Dimension	316 Stainless		18-8 Stainless		18-8 Stainless with Loctite 767	
	Pound-Inches	N-m	Pound-Inches	N-m	Pound-Inches	N-m
1/4 x 20	79	9	76	9	45	5
1/4 x 28	100	11	94	11	56	6
5/16 x 18	138	16	132	15	79	9
5/16 x 24	148	17	142	16	85	10

**Table 17. Torque Values for Stainless Steel Fasteners Larger Than 5/16-inch**

Dimension	316 Stainless		18-8 Stainless		18-8 Stainless with Loctite 767	
	Pound-Feet	N-m	Pound-Feet	N-m	Pound-Feet	N-m
3/8 x 16	21	28	20	27	12	16
3/8 x 24	23	31	22	29	13	18
7/16 x 14	33	44	31	42	19	25
7/16 x 20	35	47	33	45	20	27
1/2 x 13	45	61	43	58	26	35
1/2 x 20	47	64	45	61	27	37
9/16 x 12	59	81	57	77	34	46
9/16 x 18	66	89	63	85	38	51
5/8 x 11	97	131	93	125	56	75
5/8 x 18	108	150	104	141	62	84
3/4 x 10	132	179	128	173	77	104
3/4 x 16	130	176	124	168	75	101
7/8 x 9	203	275	194	263	116	158
7/8 x 14	202	273	193	262	116	157
1 x 8	300	406	287	389	172	233
1 x 14	271	367	259	351	156	211
1-1/8 x 7	432	586	413	560	248	336
1-1/8 x 12	408	553	390	529	234	317
1-1/4 x 7	546	740	523	709	314	425
1-1/4 x 12	504	683	480	651	288	390
1-1/2 x 6	930	1261	888	1204	533	722
1-1/2 x 12	732	992	703	953	422	572

## 1.5.2 Preparation

BNUUUN02.T01 0000222511 G.2 B.3 B.2 4/20/23, 9:05 AM Released



**WARNING: Fire Hazard** — Some solvents and primers are flammable.

- ▶ Use threadlocker and primers with sufficient airflow.
- ▶ Do not use flammable material near ignition sources.

1. Clean all threads with a wire brush or a different tool.
2. Remove the grease from the fasteners and the mating threads with solvent. Make the parts dry.



**NOTE:** LocTite 7649 Primer™ or standard solvents will remove grease from parts.

3. Apply a spray of LocTite 7649 Primer™ or equal on the fasteners and the mating threads. Let the primer dry for one minute minimum.

### 1.5.3 How to Apply a Threadlocker

BNUUUN02.T02 0000222508 G.2 B.3 B.2 4/20/23, 9:09 AM Released



**CAUTION: Malfunction Hazard** — Heat, vibration, or mechanical shocks can let the fasteners loosen if you do not apply the threadlocker correctly. Loose fasteners can cause malfunctions of the equipment.

- ▶ Read the threadlocker manufacturer's instructions and warnings. Obey these instructions.

Apply the threadlocker only to the areas where the fastener threads and the mating threads engage.

**Figure 2. Apply Threadlocker in a Blind Hole**

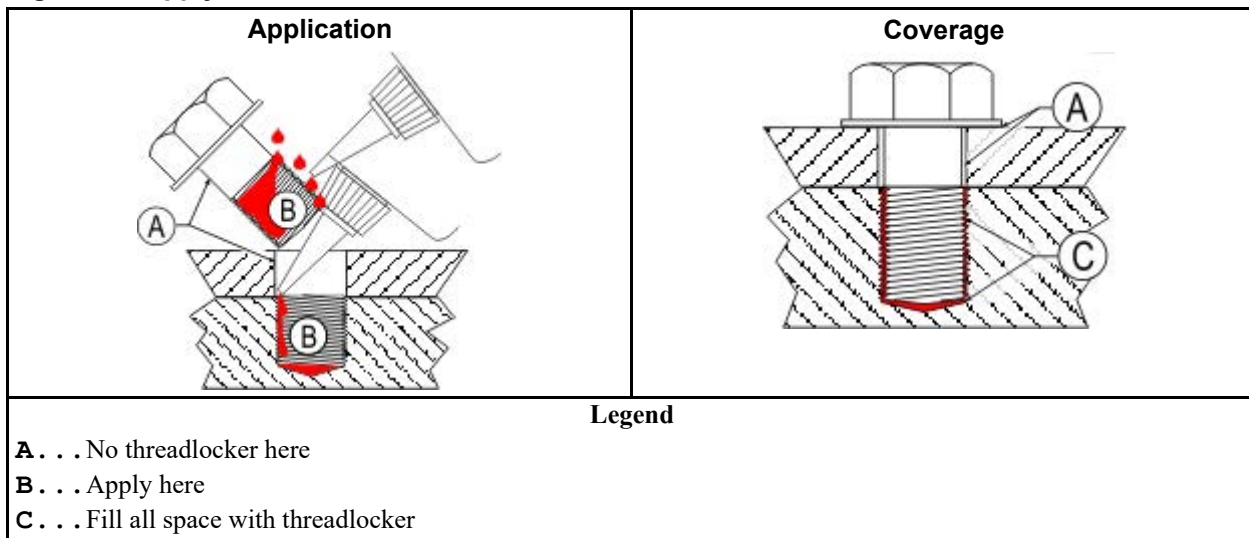

#### 1.5.3.1 Blind Holes

BNUUUN02.T03 0000222507 G.2 B.3 A.3 1/2/20, 2:14 PM Released

1. Apply the threadlocker down the threads to the bottom of the hole.
2. Apply the threadlocker to the bolt.
3. Tighten the bolt to the value shown in the correct table ([Table 10: Threadlocker by the Diameter of the Bolt \(see below Note \), page 30](#) to [Table 16: Torque Values for Stainless Steel Fasteners 5/16-inch and Smaller, page 32](#) ).

#### 1.5.3.2 Through Holes

BNUUUN02.T04 0000222506 G.2 B.3 A.3 11/26/19, 2:51 PM Released

1. Put the bolt through the assembly.
2. Apply the threadlocker only to the bolt thread area that will engage the nut.
3. Tighten the bolt to the value shown in the correct table ([Table 10: Threadlocker by the Diameter of the Bolt \(see below Note \), page 30](#) to [Table 16: Torque Values for Stainless Steel Fasteners 5/16-inch and Smaller, page 32](#) ).

**Figure 3. Apply Threadlocker in a Through Hole**

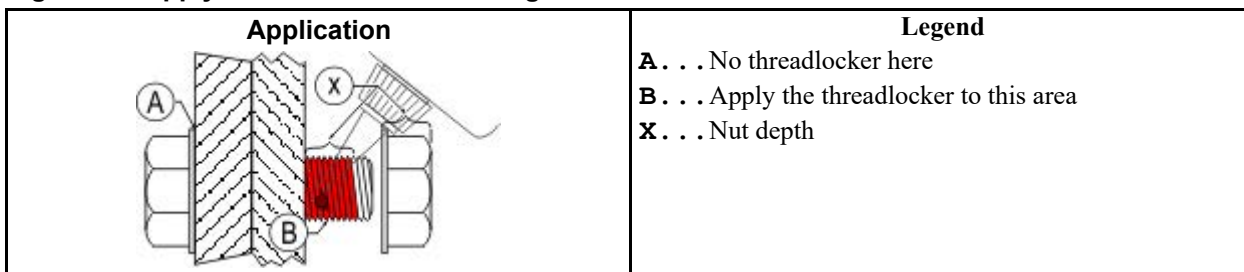

### 1.5.3.3 Disassembly

BNUUUN02.C07 0000222444 G.2 B.3 A.3 11/26/19, 2:59 PM Released

For high-strength threadlocker, apply heat for five minutes. Disassemble with hand tools while the parts are hot.

For low-strength and moderate-strength threadlocker, disassemble with hand tools.

**Figure 4. Use heat for disassembly of fasteners with threadlocker.**

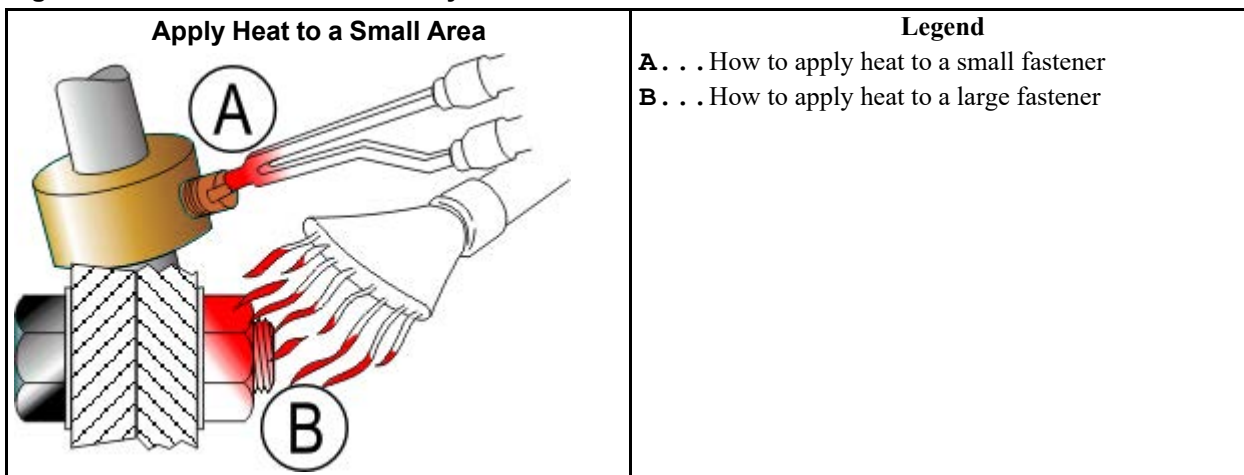

# 2 Important Installation Precautions

BFUUUF01 / 2023174

BNUUUF01 0000109243 D.2 4/26/23, 10:44 AM Released

## 2.1 External Fuse/Breaker, Wiring, and Disconnect Requirements

BNUUUF01.C01 0000109242 G.2 D.2 A.4 1/2/20, 2:14 PM Released

An external fuse or circuit breaker and a disconnect switch must be provided in the facility for (and dedicated to) the machine. These may be in the same or separate, **permanently mounted** electric boxes. Electric power and ground connections will be made between the incoming power junction box on the machine and this external box (or one of the boxes).

### 2.1.1 Fuse or Circuit Breaker Size

BNUUUF01.R01 0000109241 G.2 D.2 A.4 1/2/20, 2:14 PM Released

Refer to the “External Fuse and Wire Sizes...” document for your machine model. This document will be found in the machine's installation manual, available from the parts department. Choose the fuse or circuit breaker from the appropriate column of the table provided, as follows:

**If a fuse is used** — Match the fuse listed in the “Fuse” column for your machine's voltage. The specified fuse sizes are consistent with the USA National Electric Code (NEC), section 430-52, exception No. 2, Part B, which states: “The rating of a time-delay (dual-element) fuse shall be permitted to be increased, but shall in no case exceed 225 percent of the full-load current.”

**If a standard circuit breaker is used** — Match the amperage rating listed in the “Breaker” column for your machine's voltage.

**If an inverse time circuit breaker is used** — Match the characteristics (amperage rating) of the fuse listed in the “Fuse” column for your machine's voltage. When applied to an inverse time circuit breaker, the specified fuse sizes are consistent with the USA National Electric Code (NEC), section 430-52, exception No. 2, Part C, which states: “The rating of an inverse time circuit breaker shall be permitted to be increased, but shall in no case exceed 400 percent for full-load currents of 100 amperes or less.”

### 2.1.2 Wire Size

BNUUUF01.R02 0000109240 G.2 D.2 A.4 1/2/20, 2:14 PM Released

Use wiring no smaller than that listed for your machine's voltage in the “Wire size...” column in the “External Fuse and Wire Sizes...” document. The table value applies to runs up to 50 feet (15 meters). Use the next larger size for runs 50 to 100 feet (15 to 30 meters). Use wire two sizes larger for runs greater than 100 feet (30 meters). If an inverse time circuit breaker is used and local codes require a larger wire size than that specified by Milnor, abide by the local code.



**NOTICE:** The specified wire size may appear too small for the fuse or circuit breaker shown. However, it is consistent with both the load imposed and with the USA National Electric Code.

### 2.1.3 Ground

BNUUUF01.R03 0000109239 G.2 D.2 A.4 1/2/20, 2:14 PM Released

The ground wire and connections must ensure a reliable earth ground (zero potential). Use wiring of at least as large a gauge as that required for incoming power. Do not rely on conduit, machine anchorage, etc. Use the ground lug provided in the incoming power junction box on the machine.

### 2.1.4 Disconnect Switch for Lockout/Tagout

BNUUUF01.R04 0000109238 G.2 D.2 A.5 1/2/20, 2:14 PM Released

The disconnect switch must permit personnel to disconnect and lockout/tagout electric power from the machine. In the USA, refer to OSHA standard 1910.147 “The control of hazardous energy (lockout/tagout)”. Refer to the USA National Electric Code for requirements on locating the switch. In other locales, abide by these standards if no other local codes apply.

### 2.1.5 Using GFCI (Ground Fault Circuit Interrupter) Device

BNUUUF01.R05 0000571262 G.2 D.2 A.2 4/26/23, 10:44 AM Released

The AC Drive will most likely cause the GFCI protection device to trip. The reason the AC Drive will cause this tripping of the GFCI is the Common Mode Current or Common Mode Noise (CM Noise) that the VFD is producing.

Use a GFCI with a higher trip level.



**NOTE:** Choose a GFCI designed specifically for an AC drive. The operation time should be at least 0.1 s with sensitivity amperage of at least 200 mA per drive. The output waveform of the drive may cause an increase in leakage current. This may in turn cause the leakage breaker to malfunction. Increase the sensitivity amperage or lower the carrier frequency to correct the problem.

Use a type B GFCI according to IEC/EN 60755.

BNUUUI01 / 2019392

BNUUUI01 0000189337 C.3 1/2/20, 2:14 PM Released

## 2.2 Vital Information About the Forces Imparted to Supporting Structures by Laundering Machines

BNUUUI01.C01 0000189336 G.2 C.3 A.5 1/2/20, 2:14 PM Released

This document replaces Milnor® document BIWUUI02.

All laundering machines impart static and dynamic forces to the supporting structures (foundation and soil, floor, and building). Static forces include the machine weight plus the weight of the goods and water. Dynamic forces are those imparted by various machine movements as explained in [Section 2.2.2 : Major Design Considerations, page 38](#). The dynamic forces imparted to supporting structures can cause vibration and noise outside of the laundry room if supporting structures are inadequate.

## 2.2.1 Disclaimer of Responsibility

BNUUUI01.C02 0000189359 G.2 C.3 B.3 1/2/20, 2:14 PM Released

Pellerin Milnor Corporation accepts no responsibility for damage or loss as a result of:

- inadequate supporting structures
- interference with the use of the facility caused by machine operation

The facility owner/operator is solely responsible to ensure that:

- supporting structures are strong enough, with a reasonable safety factor, to safely support the operating machine or group of machines
- supporting structures are rigid enough to isolate vibrations and noise to the laundry room

If the owner/operator does not possess the necessary expertise to ensure that the facility can safely and functionally accommodate the equipment, it will be necessary to consult the appropriate expert(s), such as a structural engineer, soils engineer, and/or architect.

## 2.2.2 Major Design Considerations

BNUUUI01.C03 0000189358 G.2 C.3 A.5 1/2/20, 2:14 PM Released

- Vibration and/or noise can be felt or heard outside of the laundry room as a result of the following, if supporting structures are not sufficiently rigid:
  - Extraction (the spinning cylinder) in washer-extractors and centrifugal extractors, imparts sinusoidal forces to supporting structures as shown in [Figure 5: How Rotating Forces Act On the Foundation, page 39](#) . In rigid washer-extractors, these forces are up to 30 times that of suspended washer-extractors of the same capacity.
  - Extraction forces can be magnified many times if the rotation frequency matches the resonant frequency of supporting structures. To avoid this, supporting structures must have a natural resonant frequency many times greater than any possible rotation speed of the machine or combination of rotation speeds of all machines.
  - Each time goods fall in the rotating cylinder of a washer, washer-extractor, centrifugal extractor, or dryer, this can impart a force to the supporting structures.
  - The intermittent start and stop actions of large components inside the machine, particularly in a tilting washer-extractor, press-extractor, or centrifugal extractor, can impart intermittent forces to the supporting structures.
- The possibility of adverse consequences is significantly greater for upper floor installations than for installations at grade. Always consult a structural engineer for such an installation.
- The possibility of adverse consequences is significantly greater for installations at grade if subsidence causes a void between the foundation and the soil or if the soil itself does not provide adequate strength and rigidity. Some possible remedies are the addition of pilings or a deeper foundation, installed as to be monolithic with the existing foundation.
- Machine forces can cause damage to the machine or the floor without the correct anchorage.
- Applicable building codes, even when met, do not guarantee sufficient structural support and isolation of machine forces to the laundry room.



**Figure 5. How Rotating Forces Act On the Foundation**

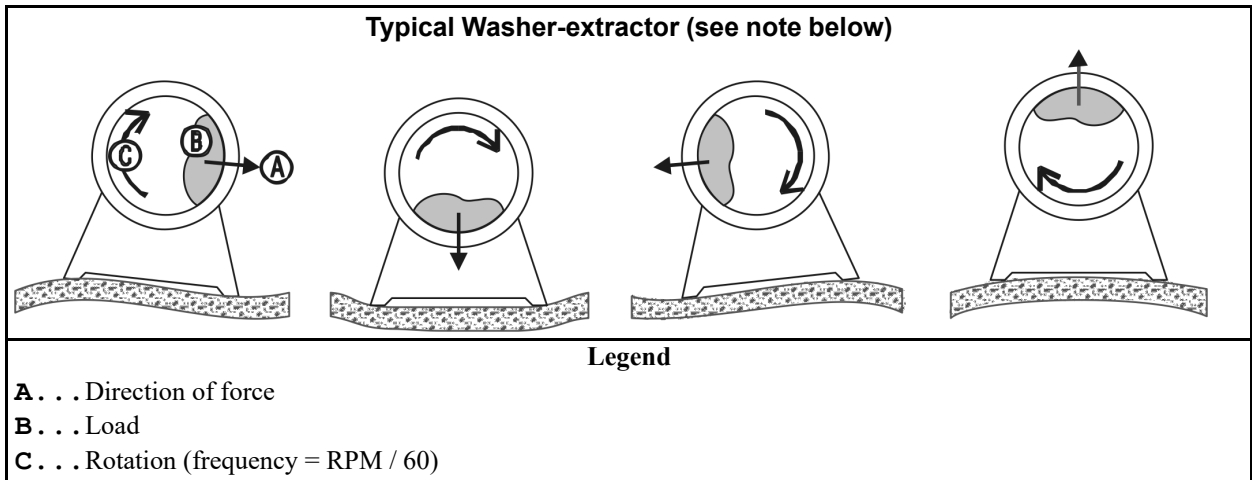

**NOTE:** This figure applies to both rigid and suspended washer-extractors and to both at-grade and upper floor installations.

### 2.2.3 Primary Information Sources

BNUUUI01.C04 0000189357 G.2 C.3 A.5 1/2/20, 2:14 PM Released

Milnor® provides, or can provide the following information of use to engineers and architects, for the given machine model:

- The machine dimensional drawing, found in the installation manual, specifies the machine’s required anchorage.
- The Milnor® Service Department can provide static and dynamic load values and frequency (extract speed) values on request.



**NOTICE:** All data is subject to change without notice and may have changed since last printed. It is the responsibility of the potential owner/operator to obtain written confirmation that any data furnished by Milnor® applies for the model number(s) and serial number(s) of the purchased machine(s).

BIWUUI03 / 2019296

BNUUUR02 0000160550 E.3 1/2/20, 2:14 PM Released

## 2.3 Prevent Damage from Chemical Supplies and Chemical Systems

BNUUUR02.C01 0000160549 G.2 E.3 B.3 1/2/20, 2:14 PM Released

All Milnor® washer-extractors and CBW® tunnel washers use stainless steel with the ANSI 304 specification. This material gives good performance when chemical supplies are correctly applied. If chemical supplies are incorrectly applied, this material can be damaged. The damage can be very bad and it can occur quickly.

Chemical supply companies usually:

- supply chemical pump systems that put the supplies in the machine,

- connect the chemical pump system to the machine,
- write wash formulas that control the chemical concentrations.

The company that does these procedures must make sure that these procedures do not cause damage. **Pellerin Milnor Corporation accepts no responsibility for chemical damage to the machines it makes or to the goods in a machine.**

### 2.3.1 How Chemical Supplies Can Cause Damage

BNUUUR02.R01 0000160548 G.2 E.3 B.5 10/1/21, 11:24 AM Released

**Dangerous Chemical Supplies and Wash Formulas** — Some examples that can cause damage are:

- a very high concentration of chlorine bleach,
- a mixture of acid sour and hypo chlorite,
- chemical supplies (examples: chlorine bleach, hydrofluosilicic acid) that stay on the stainless steel because they are not quickly flushed with water.

The book “Textile Laundering Technology” by Charles L. Riggs gives data about correct chemical supplies and formulas.

**Incorrect Configuration or Connection of Equipment** — Many chemical systems:

- do not prevent a vacuum in the chemical tube (for example, with a vacuum breaker) when the pump is off,
- do not prevent flow (for example, with a valve) where the chemical tube goes in the machine.

Damage will occur if a chemical supply can go in the machine when the chemical system is off. Some configurations of components can let the chemical supplies go in the machine by a siphon ([Figure 6, page 41](#)). Some can let chemical supplies go in the machine by gravity ([Figure 7, page 42](#)).

**Figure 6. Incorrect Configurations That Let the Chemical Supply Go In the Machine by a Siphon**

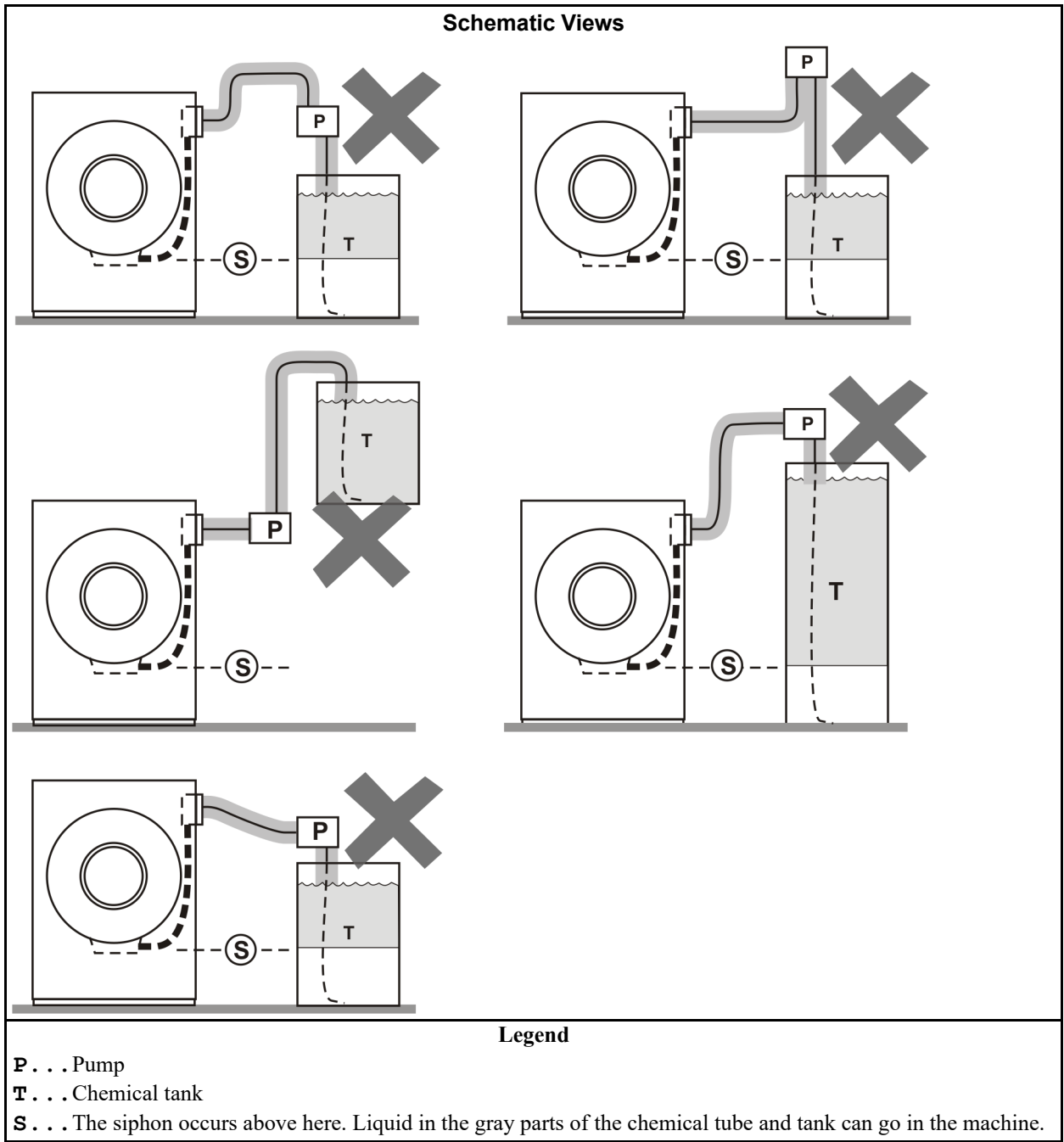

**Figure 7. Incorrect Configurations That Let the Chemical Supply Go In the Machine by Gravity**

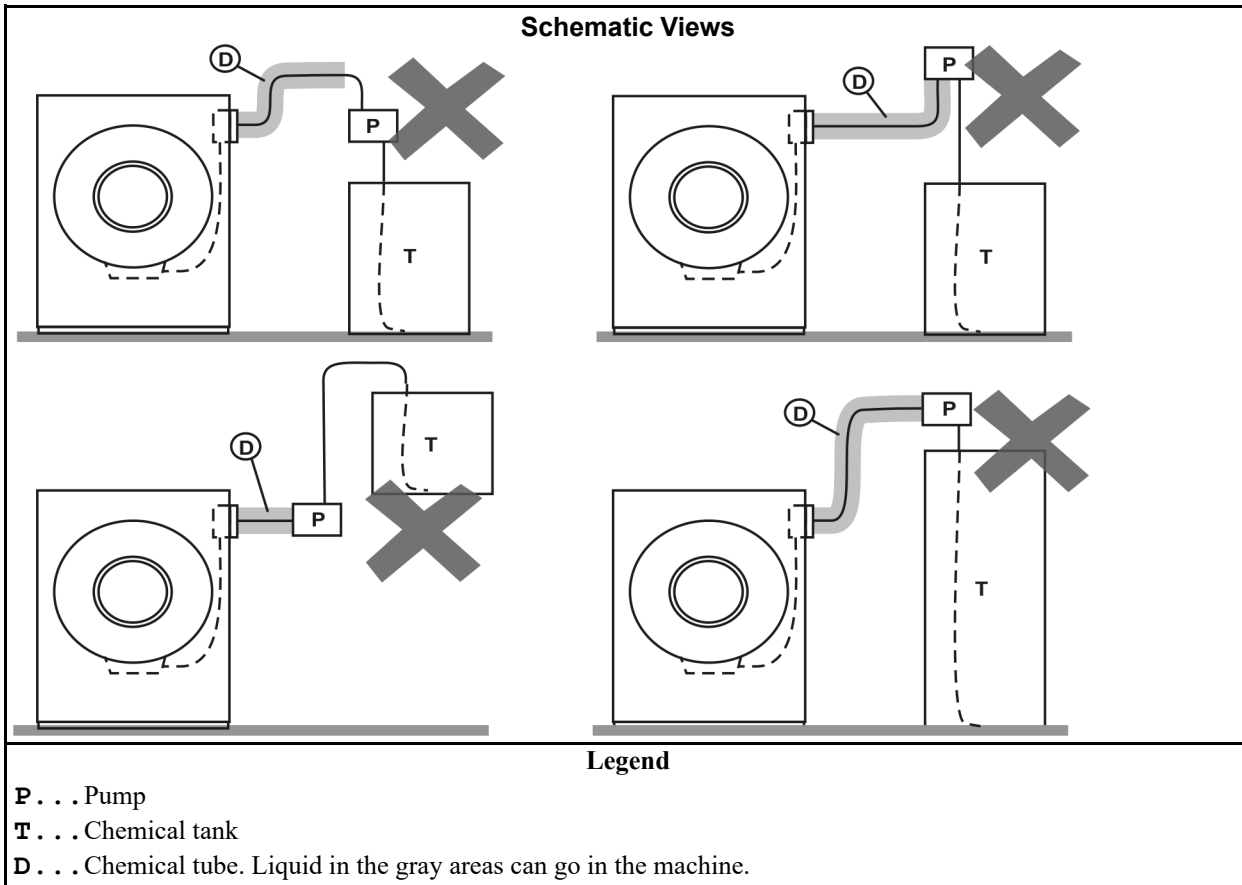

### 2.3.2 Equipment and Procedures That Can Prevent Damage

BNUUUR02.R02 0000160545 G.2 E.3 B.3 1/2/20, 2:14 PM Released

**Use the chemical manifold supplied.** — There is a manifold on the machine to attach chemical tubes from a chemical pump system. The manifold has a source of water to flush the chemical supplies with water.

**Figure 8. Examples of Manifolds for Chemical Tubes. Your equipment can look different.**

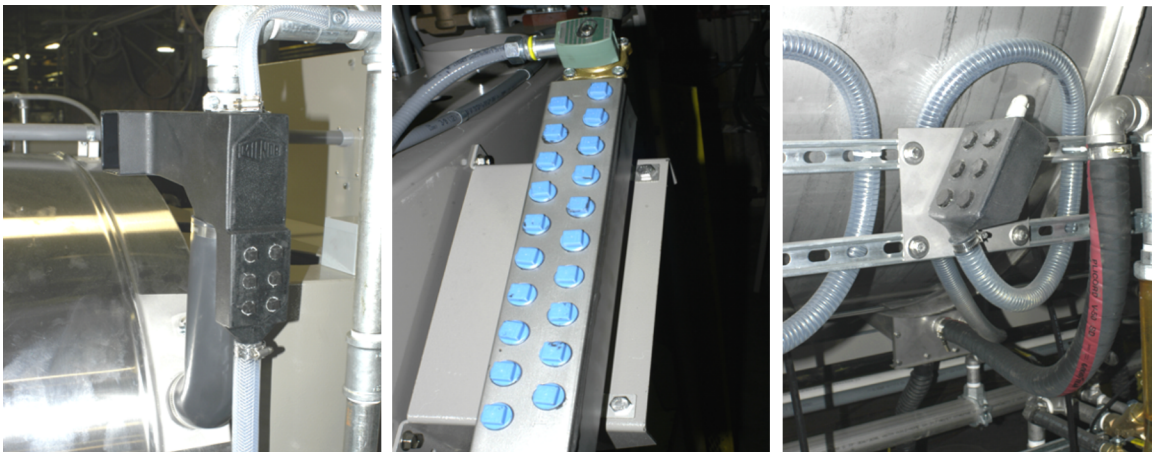

**Close the line.** — If the pump does not always close the line when it is off, use a shutoff valve to do this.

**Do not let a vacuum occur.** — Supply a vacuum breaker in the chemical line that is higher than the full level of the tank.

**Flush the chemical tube with water.** — If the liquid that stays in the tube between the pump and the machine can flow in the machine, flush the tube with water after the pump stops.

**Put the chemical tube fully below the inlet.** — It is also necessary that there is no pressure in the chemical tube or tank when the system is off.

**Figure 9. A Configuration that Prevents Flow in the Machine When the Pump is Off (if the chemical tube and tank have no pressure)**

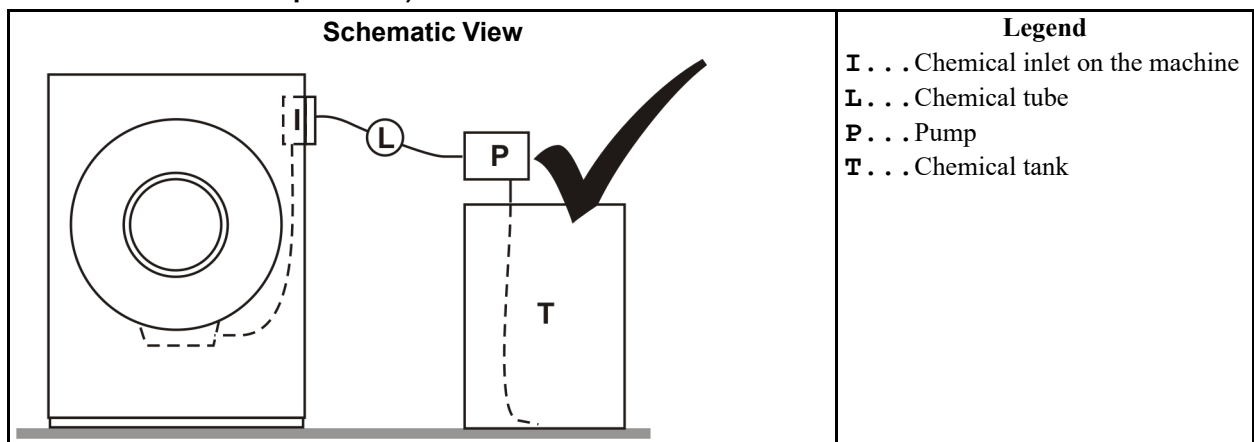

**Prevent leaks.** — When you do maintenance on the chemical pump system:

- Use the correct components.
- Make sure that all connections are the correct fit.
- Make sure that all connections are tight.

# 3 Installation Procedures

BNWUUI03 / 2019426

BNWUUI03 0000254788 B.7 1/2/20, 2:19 PM Released

## 3.1 Handling a Washer-extractor from Delivery to Final Location

BNWUUI03.C01 0000254787 G.2 B.7 C.5 1/2/20, 2:19 PM Released

This document supersedes documents BIIFLI01, BIRUUI01, MSIN0206AE, and MSIN0301AE as of October 1, 2019. It applies to all Milnor® washer-extractor models in production as of October 1, 2019.

**owner/management** the purchaser of the machine or their representative. Usually the consignee.

**transportation company** the person(s) or contractor(s) who transports the machine to the facility where it will be installed. The carrier.

**rigger** the person(s) or contractor(s) responsible to off-load the machine from the delivery vehicle, move it to its final location, and anchor it to the foundation. This can be the dealer but is often another company hired by the dealer.

**technician** a person trained in servicing Milnor® products and responsible to remove shipping restraints. This is usually a dealer employee.

### 3.1.1 Notices

BNWUUI03.R04 0000257899 G.2 B.7 A.4 1/2/20, 2:19 PM Released

**Qualified Personnel Only** — Do not attempt to move, anchor, or remove restraints from the machine unless you are a rigger or technician, as defined above.

**Disclaimer** — Pellerin Milnor Corporation is not responsible for damage to the machine after it leaves the factory. Pellerin Milnor Corporation strongly recommends that the consignee (usually the owner/management) carefully inspect the machine in its protective wrapping before off-loading and inspect the uncovered machine after off-loading. If damage occurred in transit, ensure that the transportation company acknowledges the damage in writing. Submit a damage claim as soon as possible.

**Other Tasks** — This document addresses common tasks that the rigger and technician will perform. Other tasks, not explained here, can be needed. Information about other tasks is usually provided by the dealer, the Milnor® Applications Engineering department, or the Milnor® Service department. Examples are:

- Placement of the machine on a platform, such as for laundry cart clearance or to accommodate unusual drain conditions.
- Partial disassembly and reassembly, possible on some models, for movement through small spaces.

### 3.1.2 Facility Prerequisites

BNWUUI03.R01 0000254786 G.2 B.7 B.4 1/2/20, 2:19 PM Released

Required Condition	Supporting Information
structural support	See document BNUUUI01 “Vital Information About the Forces Imparted to Supporting Structures by Laundering Machines” which can be found in the installation manual and also at <a href="https://milnor.sharefile.com/d-s8408ba617d244d98">https://milnor.sharefile.com/d-s8408ba617d244d98</a> .
protected storage	If the machine must be stored temporarily, it must be protected from dampness and excessive temperatures.
access to the final location	See the machine dimensional drawing, which can be found at the end of the installation manual, for overall dimensions. Partial disassembly is sometimes possible. Contact the Milnor® Service department.
clearances for machine movement and maintenance	See the dimensional drawing.
operational clearances	Adequate clearance around controls and for movement of laundry equipment such as carts. See the dimensional drawing.
available utilities	See the dimensional drawing and the external fuse and wire document.
available drain(s)	See the dimensional drawing. The drain valve(s) must have unrestricted access to a drain trough of sufficient capacity in the foundation.
laundry room ventilation	The machine will contribute heat and vapors to the laundry room, which must provide adequate ventilation.

### 3.1.3 Rigger Precautions

BNWUUI03.R02 0000254785 G.2 B.7 B.6 1/2/20, 2:19 PM Released



**CAUTION: Incorrect rigging** — can cause mishaps and costly machine damage.

- ▶ Know and accommodate the machine shipping weight.
- ▶ Use only lifting eyes for crane lifting.
- ▶ Use long cables or a spreader bar for crane lifting.
- ▶ Leave the machine skidded as long as possible.
- ▶ Protect fragile or sensitive machine components.
- ▶ Prepare the foundation and install anchor bolts correctly.
- ▶ Set the machine at the correct height and level.
- ▶ Apply machinery grout evenly so that support is distributed.
- ▶ Tighten anchors alternately so that the hold-down force is distributed.

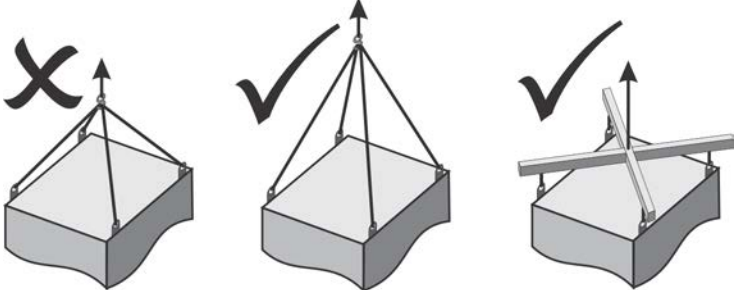
Precaution	Explanation
Know and accommodate the machine shipping weight.	Use lifting and moving equipment appropriate for the machine shipping weight, as shown on the Bill of Lading. To obtain the shipping weight in advance, contact the Milnor® Transportation department.
Use only lifting eyes for crane lifting.	Machines designed for crane lifting are provided with lifting eyes either on the structural frame or on the shell, hidden behind cosmetic panels.
Use long cables or a spreader bar for crane lifting.	
Leave the machine skidded as long as possible.	If the machine is skidded, leave the machine on the skids until the machine is as close as possible to its final location. Use care to avoid contact between the fork lift forks and fragile machine components on the un-skidded machine.
Protect fragile or sensitive machine components.	After the machine is uncovered, carefully find and read all tags on the outside of the machine. White and manila paper tags are installation precautions. See the Installation Tag Guidelines in the installation manual for additional information.
Prepare the foundation and install anchor bolts correctly.	Anchor bolt sizes and locations are shown on the dimensional drawing in the back of the installation manual. However, Milnor® recommends to use the actual machine as a template to accurately locate where the anchor bolts are to be installed in the foundation. See the anchor bolt detail on the dimensional drawing. It is not permissible to omit anchor bolts.

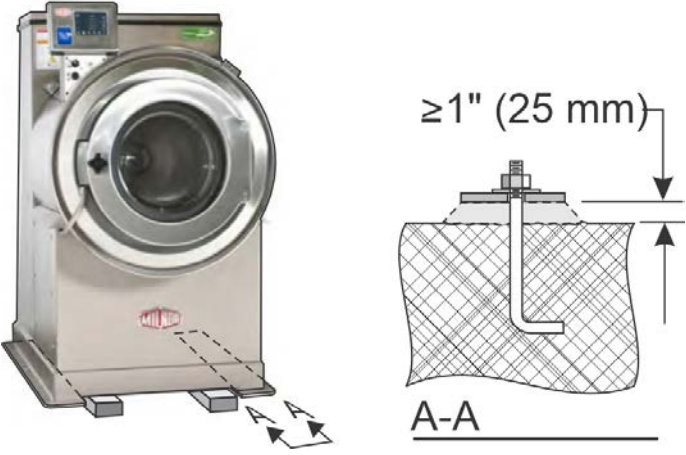

Precaution	Explanation
<p>Set the machine at the correct height and level.</p>	<p>Use blocking to get the machine base level and the base pads a minimum of 1" (25 mm) above the floor. Example:</p> 
<p>Apply machinery grout evenly so that support is distributed.</p>	<p>Fill all voids between the foundation and each base pad with industrial strength, non-shrinking grout. Allow the grout to fully cure per the grout instructions.</p>
<p>Tighten anchors alternately so that the hold-down force is distributed.</p>	<p>Raise the machine slightly and remove the wood blocking. Install a flat washer and nut on each anchor bolt and tighten incrementally in an alternating pattern. After tightening, check each anchor at least twice.</p>

### 3.1.4 Technician Precautions

BNWUUI03.R03 0000257735 G.2 B.7 A.5 1/2/20, 2:19 PM Released



**CAUTION:** Overlooked or mishandled shipping restraints — can cause costly machine damage.

- ▶ Leave all internal shipping restraints in place until the machine is anchored.
- ▶ Check for and remove shipping tie wraps.
- ▶ Check for and remove suspension hold-down hardware, if applicable.
- ▶ Check for and remove red shipping brackets, if applicable.
- ▶ See the “Cylinder inspection” warning and inspect the cylinder for smoothness.

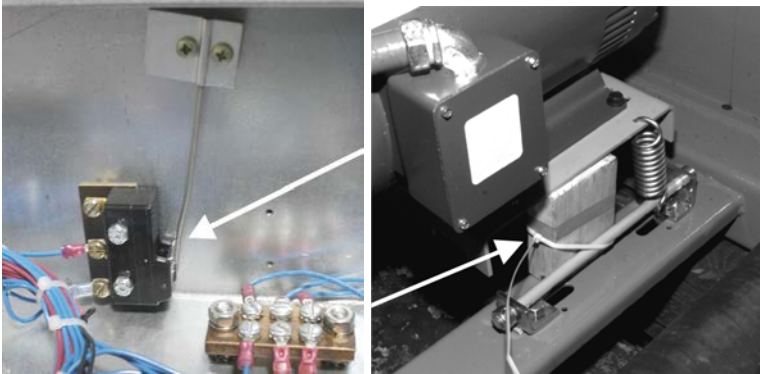
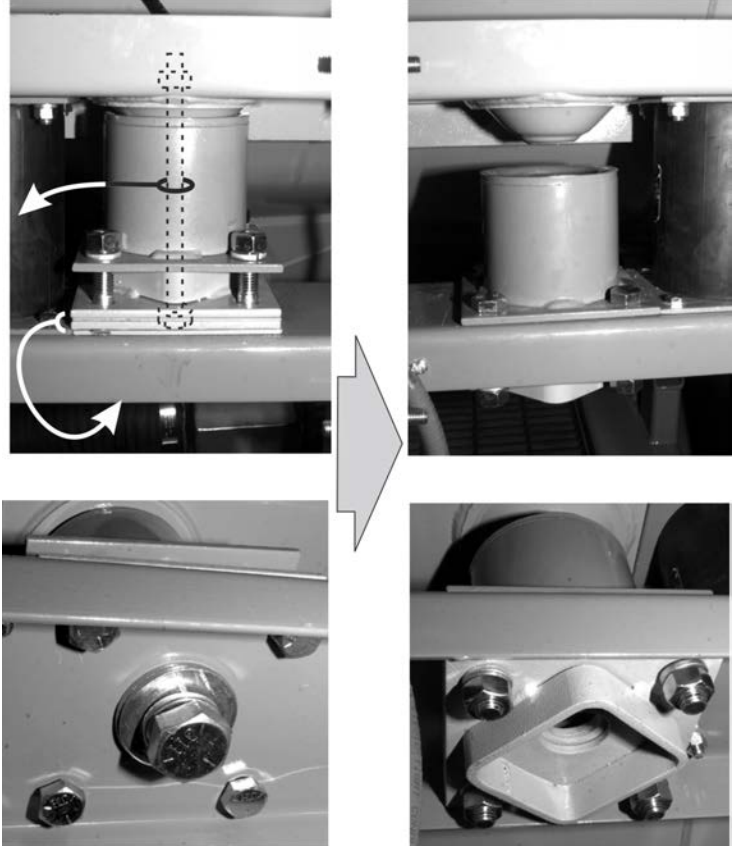
Precaution	Explanation
<p>Leave all internal shipping restraints in place until the machine is anchored.</p>	<p>The machine can have one or more internal shipping restraints to help protect components from damage until the machine is anchored. These are located inside the housing or inside electric cabinets.</p>
<p>Check for and remove shipping tie wraps.</p>	<p>Examples (varies with machine model):</p> 
<p>Check for and remove suspension hold-down hardware, if applicable.</p>	<p>See also the service manual. Example:</p> 
<p>Check for and remove red shipping brackets, if applicable.</p>	<p>Shipping brackets are painted red. See the shipping brackets parts document in the service manual.</p>



Precaution	Explanation
See the “Cylinder inspection” warning and inspect the cylinder for smoothness.	Inspect the cylinder and perforations for smoothness. <b>Pellerin Milnor Corporation cannot accept cylinder finish damage claims after the machine has been placed in service.</b> Machines are shipped with the shell door(s) closed. See the section below for information on how to open the shell door(s).



**WARNING: Cylinder inspection** — can trap you in the cylinder or seriously injure you.

- ▶ Never enter, or place body parts in the cylinder when power is supplied to the machine.
- ▶ If the machine is connected to power, lockout/tag-out power at the external disconnect switch.
- ▶ mechanically restrain the cylinder from turning.
- ▶ Have an assistant present in case of emergency.

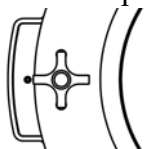
**Can the Door(s) Be Opened Before Utilities are Connected?** — The shell doors on all Milnor® washer-extractors in current production, except for the side-loading, barrier models, have one of two types of door latch: electric-operated or air operated.

Door Type	How To Open
Electric-operated: 	The machine leaves the factory with the door latched closed but not locked. Turn the door knob to open the door even when the machine does not have power. If the door will not open, the door lock mechanism moved to the locked position due to shaking in transit. In this event, wait until the machine is connected to electric power and use the controls to open the door.
Air-operated: 	The machine leaves the factory with the door(s) closed and locked (with the door plunger extended). It is possible to temporarily replace the air line that retracts the door plunger with a source of compressed air to open the door when no other utilities are connected. Otherwise, wait until utilities are connected to the machine and use the controls to open the door.

BNWUUI04 / 2021322

BNUUUF01 0000255072 C.2 8/2/21, 10:05 AM Released

### 3.2 Connection Precautions for Washer-extractors

BNWUUI04.C01 0000255071 G.2 C.2 B.2 8/2/21, 10:05 AM Released

This document supersedes documents BNWBUI01, BNWBUI02, BNWBUI03, BNWBUI04, BIRQVI01, BIMUUI02, and BIIFUI01. It applies to all Milnor® washer-extractor models in production as of October 1, 2019.

**plumber** the person(s) or contractor licensed or otherwise accepted by the local jurisdiction to perform the plumbing work described herein, and qualified to do so.

**electrician** the person(s) or contractor licensed or otherwise accepted by the local jurisdiction to perform the electrical work described herein, and qualified to do so.

**chemical supplier** the person(s) or contractor with detailed knowledge of 1) the machine controller configuration and operation, and 2) the pumped chemical delivery system, if such a system is to be used.

### 3.2.1 Notices

BNWUUI04.R03 0000255231 G.2 C.2 A.7 1/2/20, 2:19 PM Released

**Qualified Personnel Only** — Do not attempt to connect utilities to the machine unless you are a plumber, electrician, or chemical supplier, as defined above.

**Machine Must Be Anchored** — Utility connections are to be made only after the machine has been anchored. See BNWUUI03 “Handling a Washer-extractor from Delivery to Final Location.”

**Other Tasks** — This document and the documents it references address common tasks that the plumber, electrician, and chemical supplier will perform. Other tasks, not explained here, can be needed. Information about these tasks is usually provided by the dealer, the Milnor® Applications Engineering department, or the Milnor® Service department. An example is electrical interfacing with a remote Mildata® data collection system.

### 3.2.2 Utility Requirements and Related Information

BNWUUI04.R05 0000255583 G.2 C.2 A.12 1/2/20, 2:19 PM Released

Type of Information	Value or Where to Find
equipment list showing model and options purchased	For the dealer, see the order acknowledgement.
plumbing connection fitting types, sizes, and locations	See the standard and options dimensional drawings for your model located at the back of the installation manual.
water pressure range	10 – 75 psi (69 – 531 kPa) required
Cv value	See the specification sheet for your model available online at: <a href="https://www.milnor.com/specification-sheets/">https://www.milnor.com/specification-sheets/</a> . The Cv value assists the piping designer in determining flow rates and pressures.
steam pressure range	30 – 115 psi (207 – 793 kPa) required, if applicable
compressed air pressure range	85 – 110 psi (586 – 758 kPa) required, if applicable
specified voltage	See the machine nameplate or the order acknowledgement.

Type of Information	Value or Where to Find
available voltages for this model	See the specification sheet for your model available online at: <a href="https://www.milnor.com/specification-sheets/">https://www.milnor.com/specification-sheets/</a> .
multi-machine conditions that can interrupt utility service to a given machine	See dealer publication B22SL94011 “Sizing and Planning a Laundry” found online at: <a href="https://www.milnor.com/wp-content/uploads/2016/01/Sizing-and-Planning-a-Laundry_18323.pdf">https://www.milnor.com/wp-content/uploads/2016/01/Sizing-and-Planning-a-Laundry_18323.pdf</a>
approved plumbing materials	Plumbing materials must comply with applicable codes. The Milnor® factory makes no recommendations for inlet connection materials due to the many variables such as water conditions, materials cost and availability, and ongoing advances in materials technology. When drains must be piped, as apposed to a simple air drop to a sump, rubber hose and PVC are often used.

### 3.2.3 Plumber Precautions

BNWUUI04.R01 0000255070 G.2 C.2 A.9 1/2/20, 2:19 PM Released



**CAUTION: Machine damage and code violations** — can occur as a result of incorrect plumbing.

- ▶ Confirm the reliability of the piped utilities.
- ▶ Maintain connection point diameter.
- ▶ Flush fluid lines.
- ▶ Do not twist valve bodies.
- ▶ Never interchange water valve electrical connections.
- ▶ Install any vacuum breaker(s) provided or required.
- ▶ Install any water strainer(s) provided or required.
- ▶ Install a union and a shutoff valve at each hard piped connection.
- ▶ Connect a dry supply injector flush inlet to hot water and regulate it.

Precaution	Explanation
Confirm the reliability of the piped utilities.	Water and any other piped fluids (steam, compressed air) needed by the machine must be within the specified pressure range and not prone to frequent interruptions when the machine operates. See <a href="#">Section 3.2.2 : Utility Requirements and Related Information, page 50</a> .
Maintain connection point diameter.	The piping between the utility tap and the fitting on the machine must be as large or larger than the fitting. Drain piping or tubing, if any, must provide an unrestricted flow to the sump.
Flush fluid lines.	Foreign material such as debris in air lines, trapped air in water lines, and condensate in steam lines can damage machine components.
Do not twist valve bodies.	Hold a wrench on the valve side of a pipe connection to prevent the valve from twisting when you tighten the connection.

Precaution	Explanation
Never interchange water valve electrical connections.	On machines with air-operated water valves, it is permissible to exchange the pneumatic control lines, if the cold and hot connections were accidentally plumbed in reverse.
Install any vacuum breaker(s) provided or required.	If vacuum (siphon) breaker(s) are provided for fresh water connection (s), but not already installed, install them as shown on the options dimensional drawing. If vacuum breakers are required by code, but not provided, obtain and install the required hardware.
Install any water strainers provided or required.	If water strainer(s) are provided for fresh water connections, install them between the machine and incoming water. For machines with garden hose type water inlets, use 40-mesh strainers.
Install a union and a shutoff valve at each hard-piped connection.	Obtain and install the necessary hardware to permit hard-piped connections to be shut off and disconnected at the machine for maintenance. For the valve, use a ball valve, not, for example, a globe valve.
Connect a dry supply injector flush inlet to hot water and regulate it.	If the machine has a dry supply injector with an external flush water connection and hot water is available, provide hot water to this inlet. The machine will be supplied with a pressure regulator. Install this hardware at the flush water connection and confirm that the regulator is set to 28 psi (193 kPa). Steam in the hot water line will cause the supply injector to malfunction.

### 3.2.4 Electrician Precautions

BNWUUI04.R02 0000255232 G.2 C.2 A.7 1/2/20, 2:19 PM Released



**CAUTION: Machine damage, machine malfunctions, and code violations** — can occur as a result of incorrect electrical connections.

- ▶ Know the machine electrical specifications.
- ▶ Comply with the published external fuse and wire requirements.
- ▶ Confirm the reliability of the electric service.
- ▶ Confirm the machine is phased in correctly.
- ▶ Confirm the correct line voltage setting on a selectable 240/208 volt machine.
- ▶ Attach the stinger leg, if any, only to L3.

Precaution	Explanation
Know the machine electrical specifications.	Refer to the nameplate affixed to the machine.
Comply with the published external fuse and wire requirements.	These requirements are given in document BGUUUF01 “External Fuse/Breaker, Wiring, and Disconnect Requirements” and the external fuse and wire document for your machine. These documents are found at the back of the installation manual. BGUUUF01 is also available at: <a href="https://milnor.sharefile.com/d-s5e1bad2885a447e8">https://milnor.sharefile.com/d-s5e1bad2885a447e8</a>
Confirm the reliability of the electric service.	Voltage fluctuations of more than 10% above or below the specified voltage can damage electrical components, especially motors. The Milnor® factory strongly recommends that unreliable electric service is improved before the machine is put in use.
Confirm the machine is phased in correctly.	An installation tag on the machine shows the correct cylinder rotation at distribution (drain) or extract speed. If the cylinder turns in the wrong direction, reverse the wires connected to L1 and L2. Never move L3. Individual motors were phased in at the factory. Never reconnect individual motors or motor control devices.
Confirm the correct line voltage setting on a selectable 240/208 volt machine.	This precaution applies only if the nameplate voltage says 208/240V. It does not, for example, apply if the nameplate says 208V <b>or</b> 240V. The switch is near the incoming power transformer and must be in the position that matches the service voltage: 240 VAC or 208 VAC.
Attach the stinger leg, if any, only to terminal L3.	Never attach a stinger leg to terminal L1 or terminal L2.

### 3.2.5 Chemical Supplier Precautions

BNWUUI04.R04 0000255482 G.2 C.2 A.5 1/2/20, 2:19 PM Released

**Injury and severe machine damage** can occur as a result of incorrect chemical system installation.

- ▶ Understand and comply with the published connection precautions.
- ▶ Understand the machine controller.

Precaution	Explanation
Understand and comply with the published connection precautions.	The connection precautions are given in document BIWUUI03 “Prevent Damage from Chemical Supplies and Chemical Systems” in the installation manual. BIWUUI03 is also available at: <a href="https://milnor.sharefile.com/d-s79f12e8f11f42a9b">https://milnor.sharefile.com/d-s79f12e8f11f42a9b</a>
Understand the machine controller.	The machine controller is explained in detail in the reference manual for your machine, which is available from the Milnor® Parts department.

# 4 Drive Assemblies



BPWMC101 / 2022173

BPWMC101.1 0000418175 G.2 A.3 4/20/22, 8:19 AM Released

**Drive**

1 Sheet

MWF63J7, MWF63Z7, MWF77J7, MWF77Z7, MWF63C7, MWF63Y7, MWF77C7, MWF77Y7

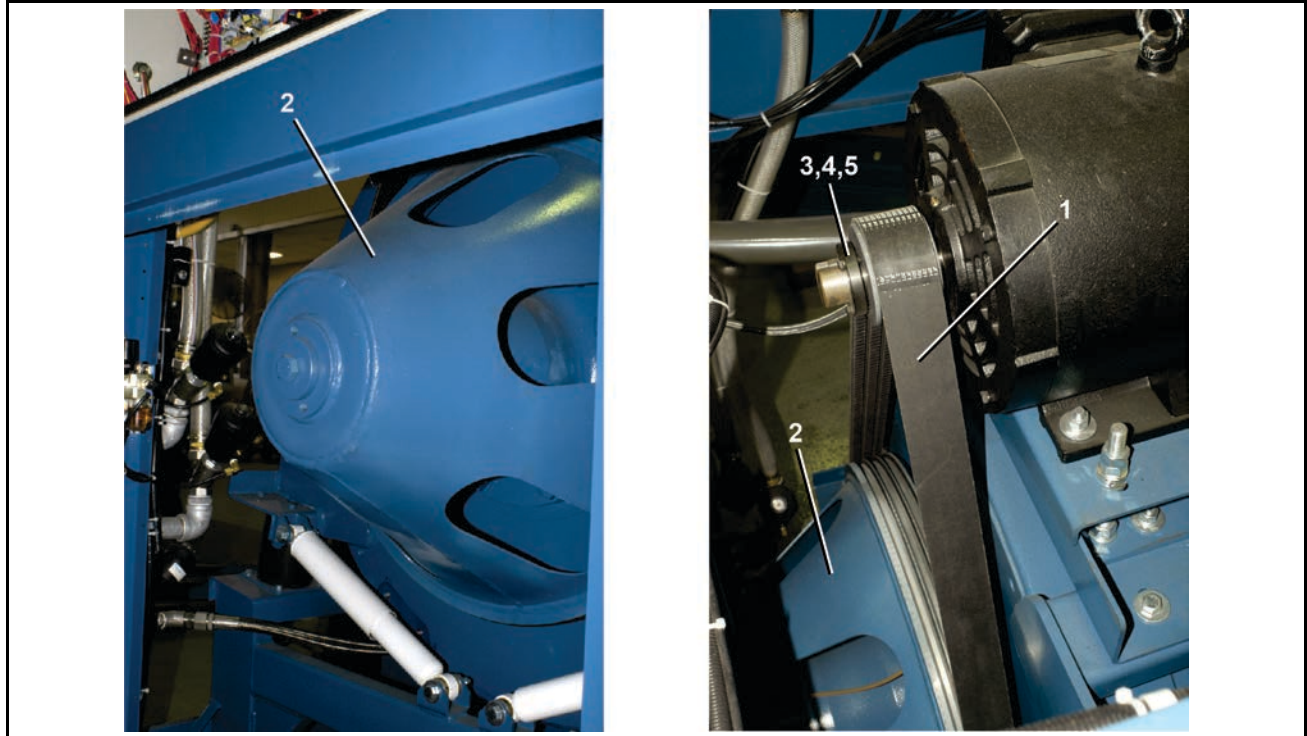
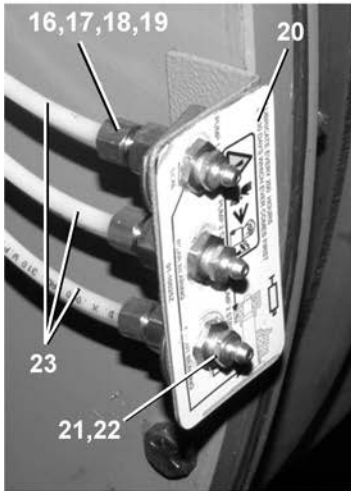
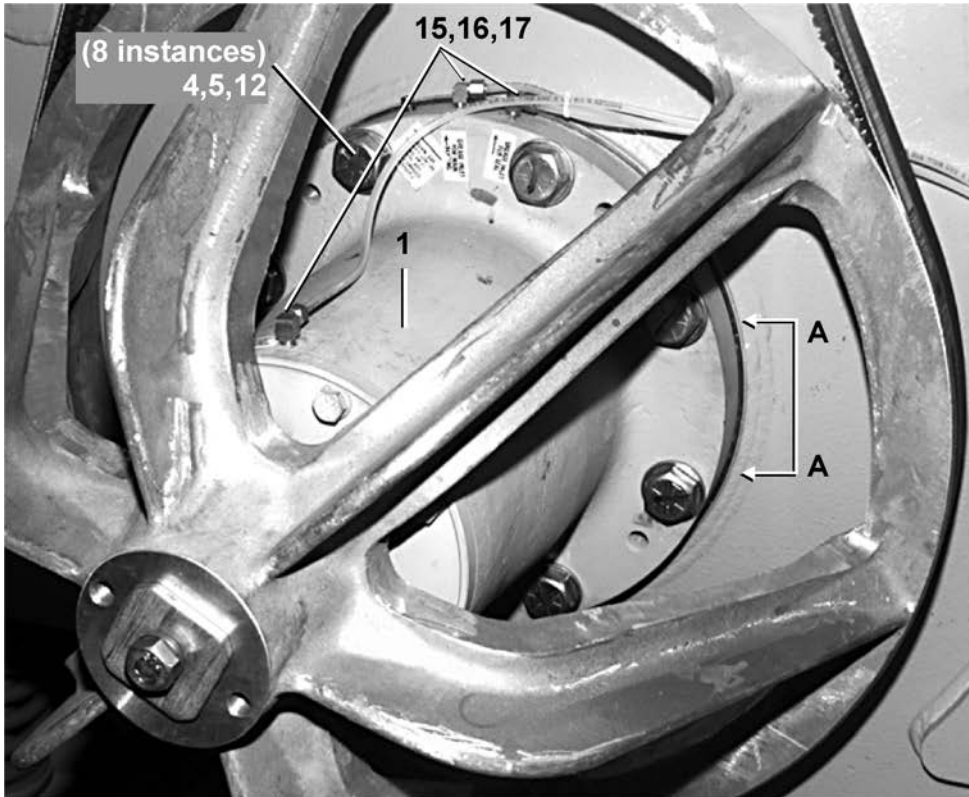

**Table 18. Parts List—Drive**

Find the assembly for your machine and the letter shown in the "Item" column. The components for your machine will show this letter or the word "all" in the "Used In" column. The numbers shown in the "Item" column are those shown in the illustrations.

Used In	Item	Part Number	Description/Nomenclature	Comments
Components				
all	1	56VB124XB3	VBAND 3RBX124 EACH=1	
all	2	98CX21931	MACH=PULLEY, FAB, 3626	
all	3	98CX034B3S	VPUL 3B3.4/A3.0 (SH) 36X, CSM	
all	4	98CXQ1MSH	BUSH=1+5/8" VPUL TAPER LOCK	
all	5	98CXE230CM	STRMACHKEY 3/8SQX2+1/2	

**Bearing MWF36, MWF45, MWF63, MWF77**



**Lubrication site**

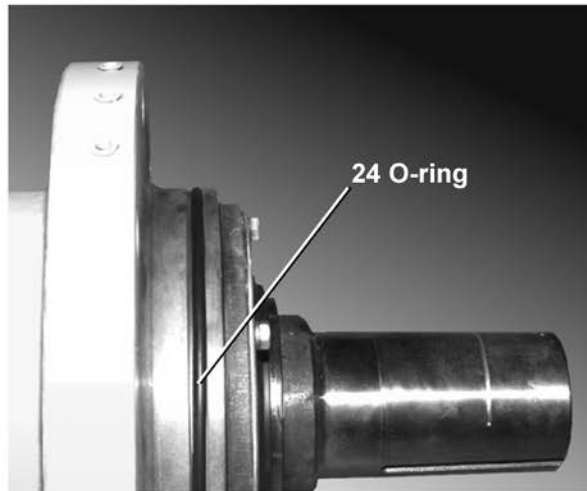

**View A-A (shell back not shown)**

**Bearing MWF36, MWF45, MWF63, MWF77**

4 Sheet

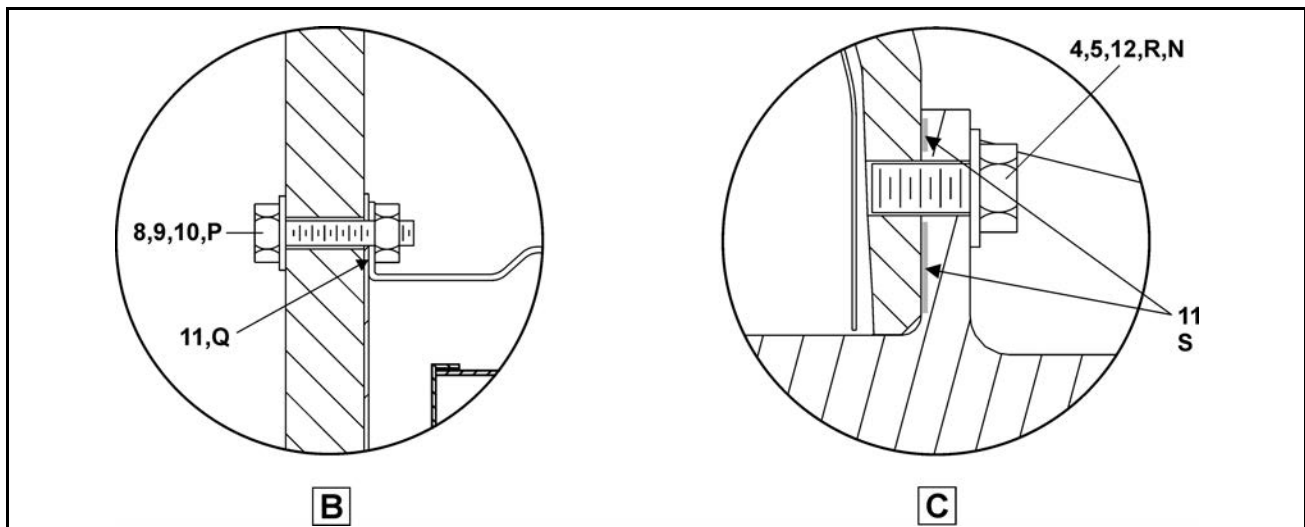
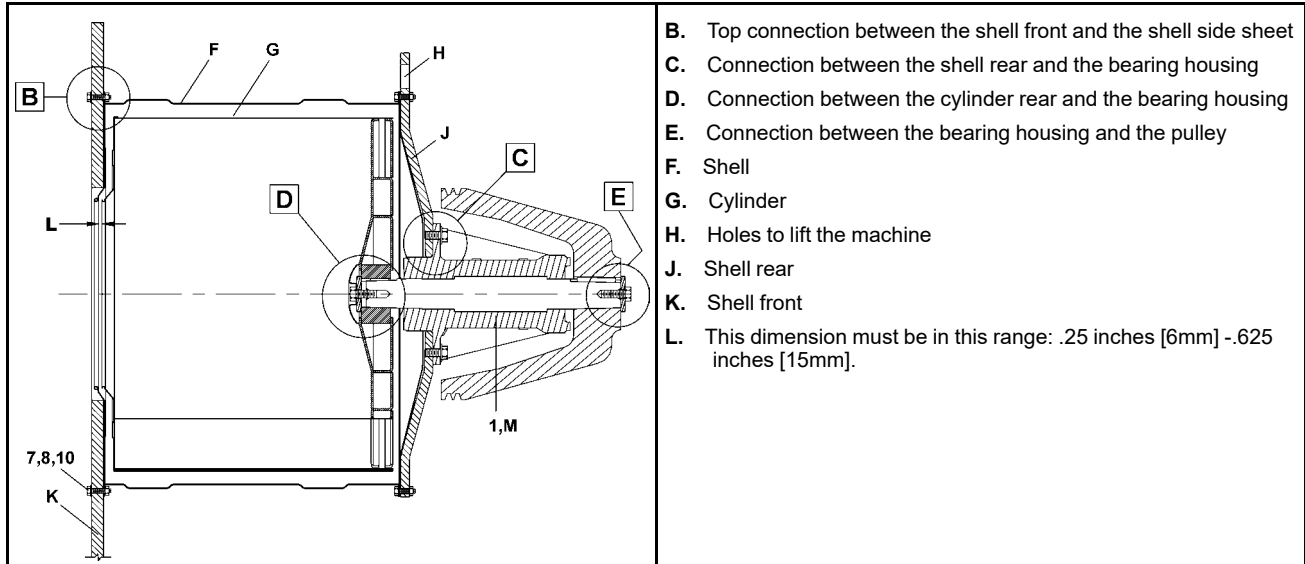

- B.** Connection between the shellfront and the shell
- C.** Connection between the shell rear and the bearing housing
- N.** 8 instances
- P.** 24 instances
- Q.** Apply silicone between the inner shell front and the shell, fully around the hole pattern.
- R.** Apply adhesive to the bolt, torque to 909 FT. LBS.
- S.** Apply silicone between the bearing housing and the shell rear, fully around the hole pattern.

**Bearing MWF36, MWF45, MWF63, MWF77**

4 Sheet

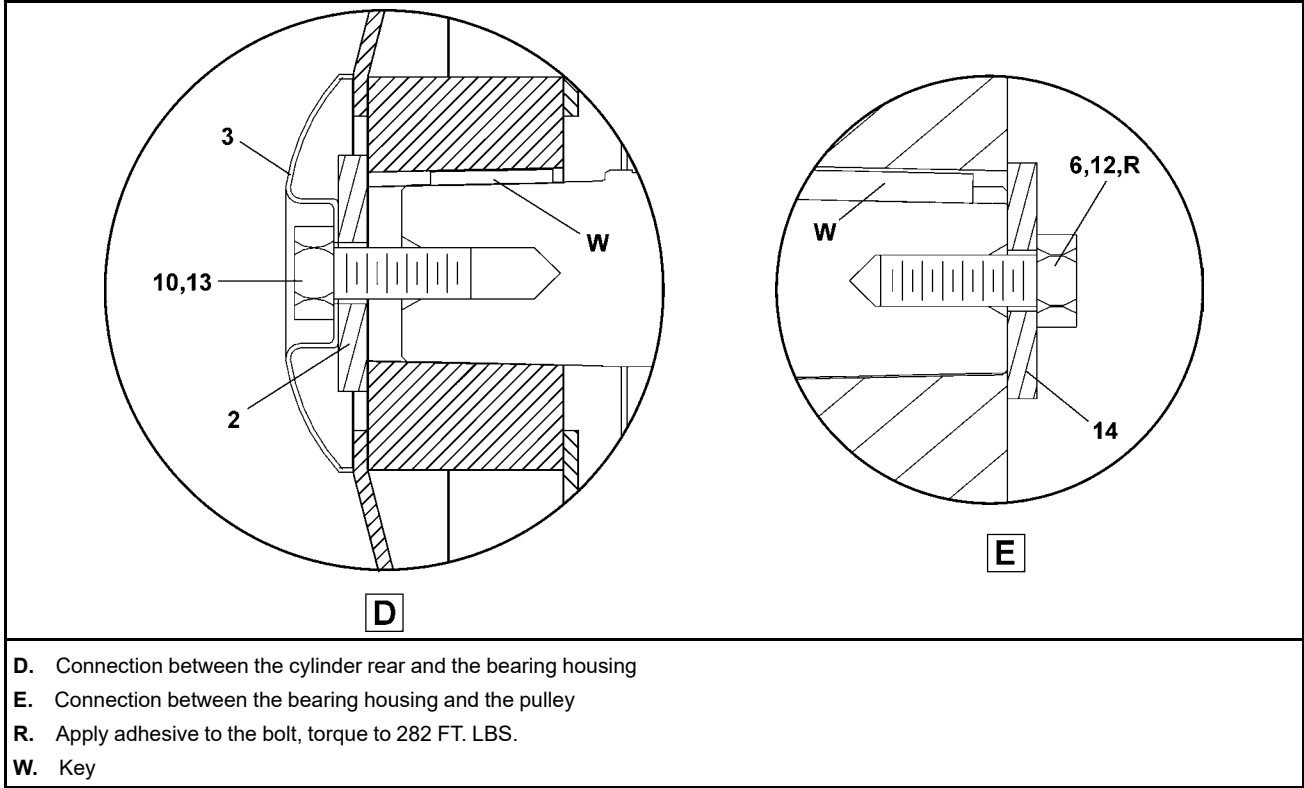

Bearing MWF36, MWF45, MWF63, MWF77

4 Sheet

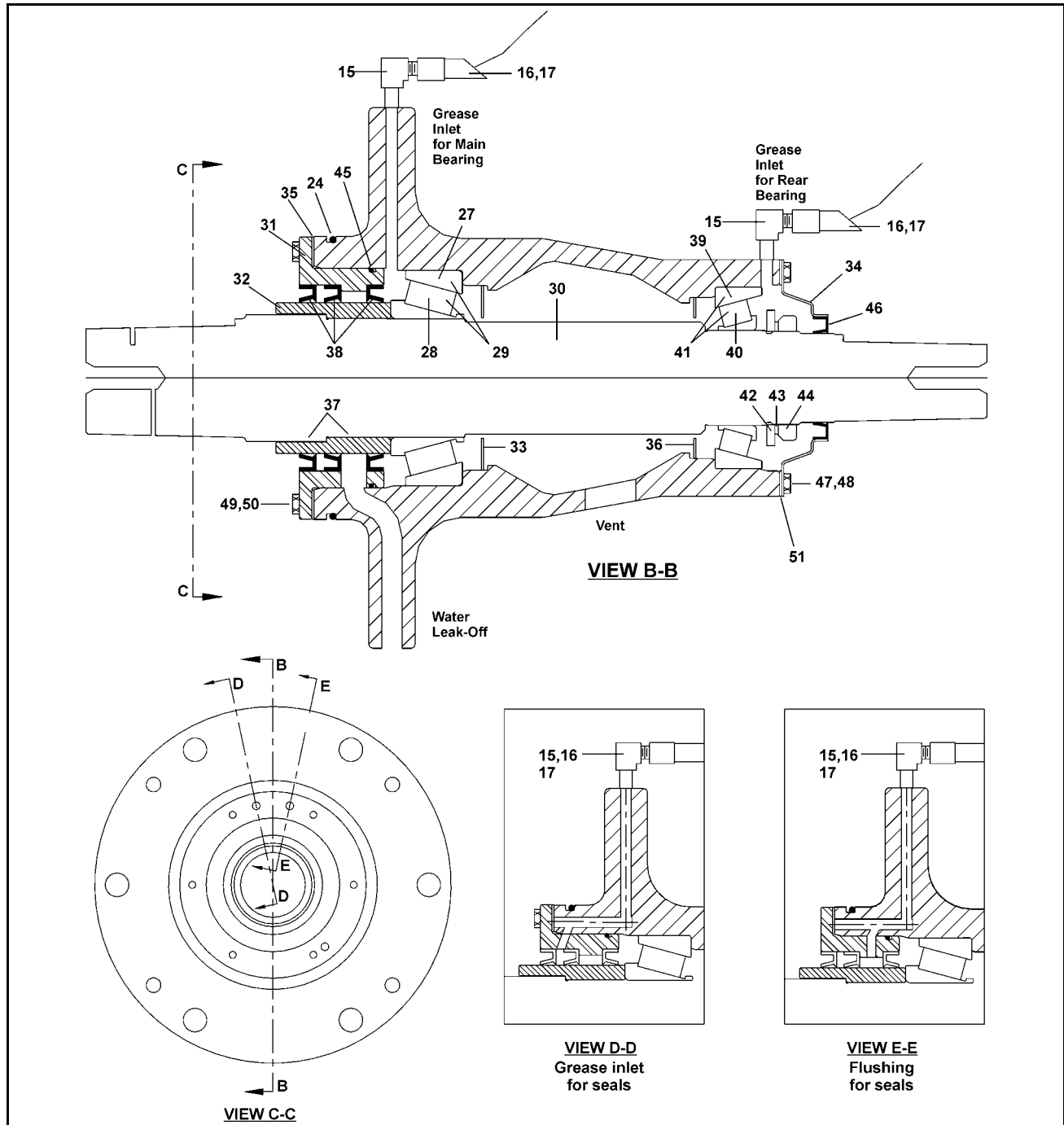

**Bearing MWF36, MWF45, MWF63, MWF77**

**Table 19. Bearing Assembly & Installation MWF45, MWF63, MWF77**

Find the assembly for your machine and the letter shown in the "Item" column. The components for your machine will show this letter or the word "All" in the "Used In" column. The numbers shown in the "Item" column are those shown in the illustrations.				
Used In	Item	Part Number	Description/Nomenclature	Comments
<b>Assemblies</b>				
A	1	98MW3601	MAIN BEARING ASSY=MWF45	MWF45, Assembly, contains items 30-55
B	1	98MW4201	MAIN BEARING ASSY=MWF77	MWF63 & MWF77, Assembly, contains items 30-55
<b>Components</b>				
A	1	98MW3601	MAIN BEARING ASSY=MWF45	Assembly, contains items 30-55
B	1	98MW4201	MAIN BEARING ASSY=MWF77	Assembly, contains items 30-55
A	2	98CMCR0950	SHAFT RETNR SPACER METRIC	
B	2	98CMCR4216	RESISTOR 42X 225W 5% 10 OHM	
all	3	98CMCR0949	COVER SHAFT RETAINER METRIC	
B	4	15K253M	HEXCAPSCR M24-3.0X75CLS10.9 Z	
A	5	15U316M	FLTWASH D16 HARD HV200 D16 Z	
B	5	15U393	FLTWASH 1" HARD ASTM F436	
all	6	15K232M	HEXCAPSCR M20X50 10.9 ZINC	
A	7	15K127M	HEXFLGSCR 3/8-16 X2.5 GR8 ZINC	
B	7	15K191HM	HEXCAPSCR M12*90 GR10.9 CS	
A	8	15G206M	HEX NUT M10 ZINC	
B	8	15G230M	HEXNUT M12 GRADE 10.9 CS	
A	9	15K180M	M10-1.5X50HX HD CAP SCR DIN931	
B	9	15K191CM	HEXCAPSCR M12*65 GR10.9 CS	
A	10	15U266	FLATWASHER 1"0DX7/16"IDX3/16"	
B	10	15U283	12MM WASHER HARD DIN 6916 ZINC	
A	11	20C040B	SUPERFLEX CLR RTV SIL 10.1OZ	
B	12	20C007G	THDLOCKSEAL LCT24231 RMUBL50CC	
all	13	15B201	HEXCAPSCR M20-2.5 X 50M 18-8	
all	14	98CMCR3023	SHAFT RETNR SPACER=3022X CSM	
all	15	98CX932503	PIPE FITTING, 90 DEGREE, .25X1/8 BSP	
all	16	98CX961460A	SLEEVE DELRIN 6MM	
all	17	98CX961460	TUBE INSERT 4MM	
all	18	98CX932801	PIPE FITTING, 6.5X1/4 BSP	
all	19	15U281A	WASHER=CLIPPED 1/2 ID .06THK	
all	20	01 10025Z	NPLT:BEARING&SEAL LUB-42" & 36"	
all	21	98CX931701	HEXBUSH, 1/4X1/8 BRASS BSP	
all	22	98CX961708	GREASE FITTING, 1/8BSP ZINC	
all	23	98CX910823	FLEXIBLE TUBING, 4X6MM OD	

## Bearing MWF36, MWF45, MWF63, MWF77

4 Sheet

Table 19 Bearing Assembly &amp; Installation MWF45, MWF63, MWF77 (cont'd.)

Find the assembly for your machine and the letter shown in the "Item" column. The components for your machine will show this letter or the word "All" in the "Used In" column. The numbers shown in the "Item" column are those shown in the illustrations.				
Used In	Item	Part Number	Description/Nomenclature	Comments
A	24	60C170	ORING 8"IDX3/16CS BUNA70 #369	
B	24	60C176	ORING 10 IDX1/4"CS BUNA-N#449	
A	27	54A337	CUP 6535 SKF 1/BOX	
A	28	54A336	CONE 6580 S-ROW S-BORE SKF1/BX	
B	29	54AT101190	TIMK HH221449/HH221410=4"BORE	
A	30	98MW3611	MACH=MAIN SHAFT MWF45	
B	30	98MW4211	MACH=MAIN SHAFT MWF77	
A	31	98CMCR3612	MACH=FRONT SEAL HOLDER 36X	
B	31	98CMCR4214	MACH=FRONT SEAL HOLDER 42X	
A	32	98CMCR3613	SEAL SLEEVE=BRG ASSY 36X	
B	32	98CMCR4215	SEAL SLEEVE=BRG ASSY 42X	
A	33	02 21542	FRONT GREASE SHIELD 3630F	
B	33	98MW25007	FRONT GREASE SHIELD MWF77	
A	34	02 21545	REAR SEAL HOLDER 3630F8	
B	34	98MW25005	REAR SEAL HOLDER MWF77	
A	35	02 21547	GASKET=FRNT SEAL HOLDR 3630F	
B	35	02 21048	GASKET=EXCLUDR SEAL 4232F	
A	36	02 21550	REAR GREASE SHIELD 3630F	
B	36	98MW25008	REAR GREASE SHIELD MWF77	
A	37	20C011C	RETAINCMPD PRESSFIT LOC#60941	
B	37	20C012DA	RETAINCMPD ADH LCT#68060 250ML	
A	38	24S114	SEAL 4.5X5.5X.50 JM# 9170 LUP	
B	38	24S135	SEAL5.188X6.5X.5 #05187336LPDN	
B	39	54A337	CUP 6535 SKF 1/BOX	
B	40	54A336	CONE 6580 S-ROW S-BORE SKF1/BX	
A	41	54A335465	TIM H414210/H414249=2.8125"BORE	
A	42	56ATW14	TONGUE WASH TIM K91514 FOR N14	
B	42	56ATW16	TONGUE WASH T#K91516 FOR AN16	
A	43	56AHW114	TW114 BEARING LOCWASHER	
B	43	56AHW116	TW116 BEARING LOCKWASHER	
A	44	56AHN14	N14 BEARING LOCKNUT	
B	44	56AHN16CM	AN16 BEARING LOCKNUT, MWF77	
A	45	60C169	ORING 7+3/4ID1/8 BUNA70 #265	
B	45	60C160J	ORING 6+1/4ID1/8CS BUNA70 #259	

## Bearing MWF36, MWF45, MWF63, MWF77

4 Sheet

Table 19 Bearing Assembly &amp; Installation MWF45, MWF63, MWF77 (cont'd.)

Find the assembly for your machine and the letter shown in the "Item" column. The components for your machine will show this letter or the word "All" in the "Used In" column. The numbers shown in the "Item" column are those shown in the illustrations.				
Used In	Item	Part Number	Description/Nomenclature	Comments
all	46	24S053	SEAL 2.625X3.625X.437#10051L5 03Z/A	
all	47	15K039M	HXCAPSCR M6X20, 8.8,ZINC	
all	48	15U180	LOCKWASHER MEDIUM 1/4 ZINCPL	
all	49	15K117MS	HXCAPSCR M10X35 SS 18-8	
X	50	15U266MS	FLTWSHR METRIC D10 SS18-8	
A	51	02 21546	EXCLUDER SEAL GASKET	
B	51	02 21047	GASKET=FRNT SEAL HOLDR 4232F	



# 5 Suspension

Suspension

MWF63J7, MWF63Z7, MWF77J7, MWF77Z7, MWF63C7, MWF63Y7, MWF77C7, MWF77Y7

MWF77J7, MWF77Z7, MWF77C7, MWF77Y7

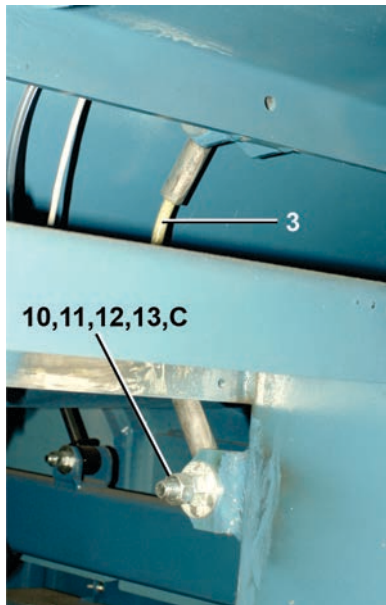
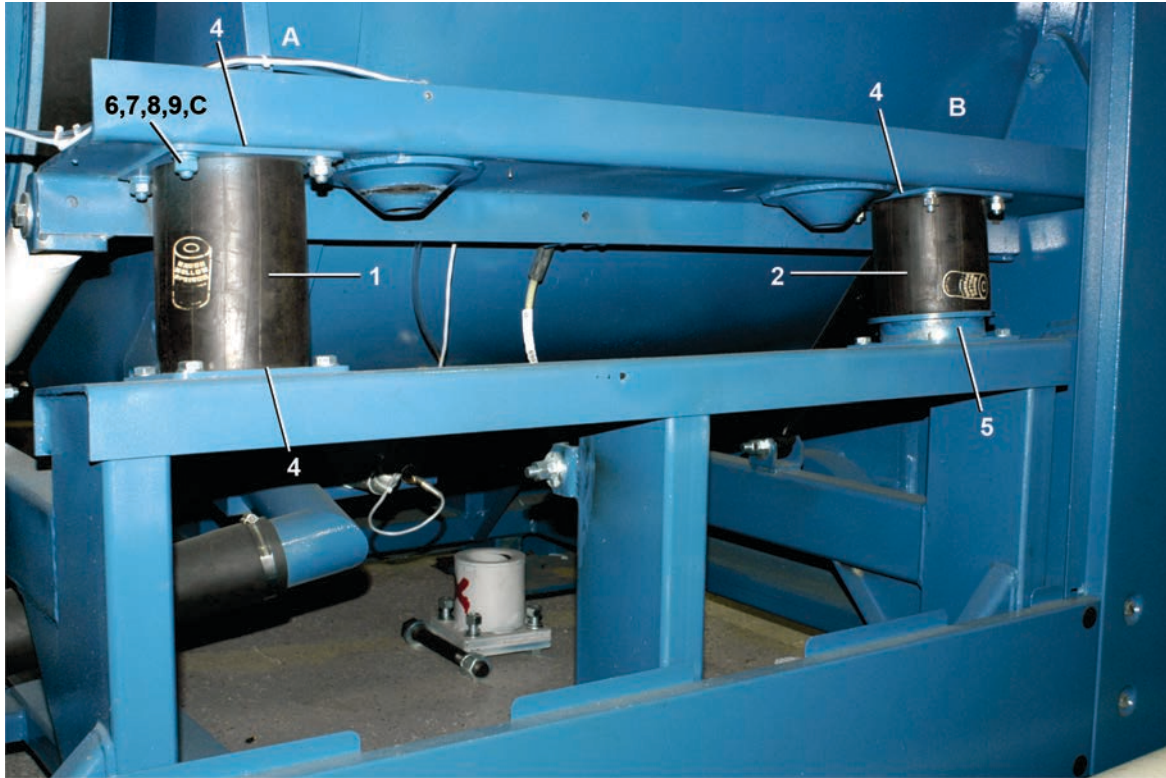

MWF63J7, MWF63Z7, MWF63C7, MWF63Y7



Legend

- A . . . Rear
- B . . . Front
- C . . . Typical

**Suspension**

2 Sheets

MWF63J7, MWF63Z7, MWF77J7, MWF77Z7, MWF63C7, MWF63Y7, MWF77C7, MWF77Y7

**Table 20. Parts List—Suspension**

Find the assembly for your machine and the letter shown in the "Item" column. The components for your machine will show this letter or the word "all" in the "Used In" column. The numbers shown in the "Item" column are those shown in the illustrations.				
Used In	Item	Part Number	Description/Nomenclature	Comments
Reference Assemblies				
	A		REFERENCE	MWF77_
	B		REFERENCE	MWF63_
Components				
A	1	60B134	MM SPRG 4.5X1X7	
B	1	60B127	MM SPRG 4X2X6	
all	2	60B136	MM SPRG 4.5X2X6	
all	3	27A969	CABLE ASSY SAVA#205801	
all	4	98MW21170A	SUPPORT=MM SPRG FRONT UPPER	
all	5	98MW21174	SUPPORT=MM SPRG FRONT LOWER	
all	6	15K100M	HXCAPSCREW M10X30 8.8 ZINC	
all	7	15G206M	HEX NUT M10 ZINC	
all	8	15U266M	FLTWSHR D10 ZINC	
all	9	15U275M	LOCKWSHR D10 ZINC	
all	10	15K191HM	HEXCAPSCR M12*90 GR10.9 CS	
all	11	98CX773113	HEXNUTM12, ZINC	
all	12	98CX773513	FLATWASHER, D12 ZINC	
all	13	15U283M	LOCKWSHR D12 ZINC	

# Shocks

2 Sheets

MWF63J8, MWF63Z8, MWF77J8, MWF77Z8

Rear Shocks

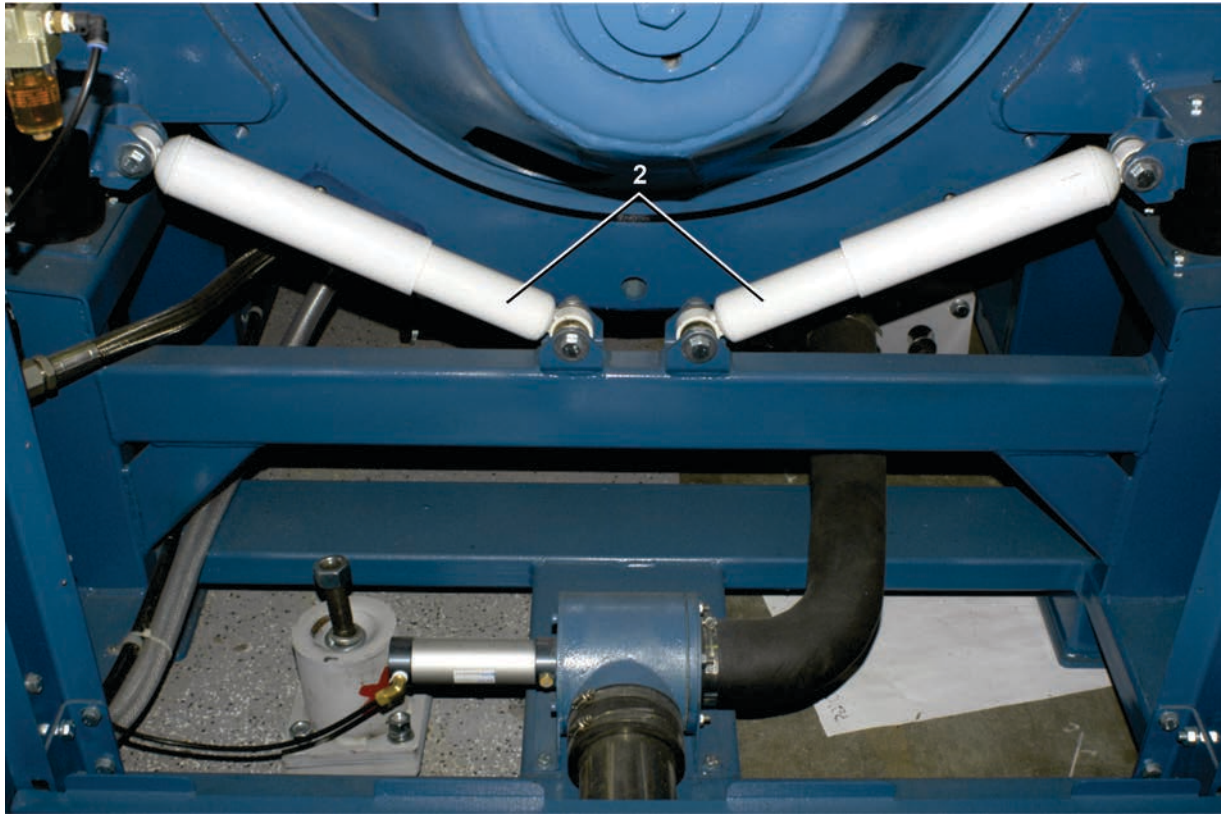

Front Shocks

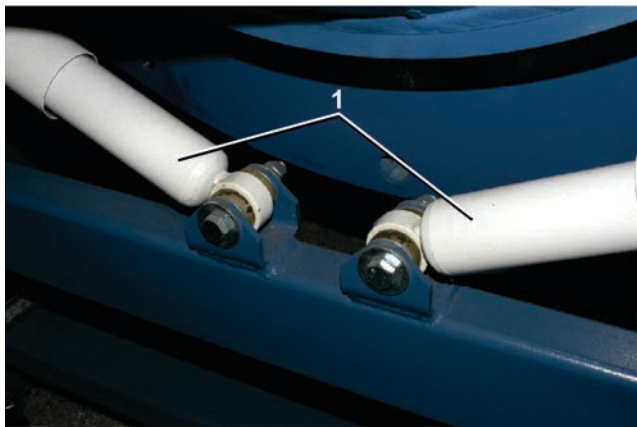

# Shocks

2 Sheets

MWF63J8, MWF63Z8, MWF77J8, MWF77Z8

**Table 21. Parts List—Shocks**

Find the assembly for your machine and the letter shown in the "Item" column. The components for your machine will show this letter or the word "all" in the "Used In" column. The numbers shown in the "Item" column are those shown in the illustrations.				
Used In	Item	Part Number	Description/Nomenclature	Comments
Components				
all	1	60BS6838	SHOCK ABSORBER = ARVIN #65907340E	
all	2	60BS6832	SHOCK ABSORBR GABRIEL #65488440X	

# 6 Door Assemblies

This page intentionally blank

BPWMCD02 / 2023092

BPWMCD02.1 0000418850 G.2 B.2 2/27/23, 4:50 PM Released

## 26" Door

4 Sheets

MWF63J7, MWF63Z7, MWF77J7, MWF77Z7, MWF63C7, MWF63Y7, MWF77C7, MWF77Y7





## 26" Door

4 Sheets

MWF63J7, MWF63Z7, MWF77J7, MWF77Z7, MWF63C7, MWF63Y7, MWF77C7, MWF77Y7

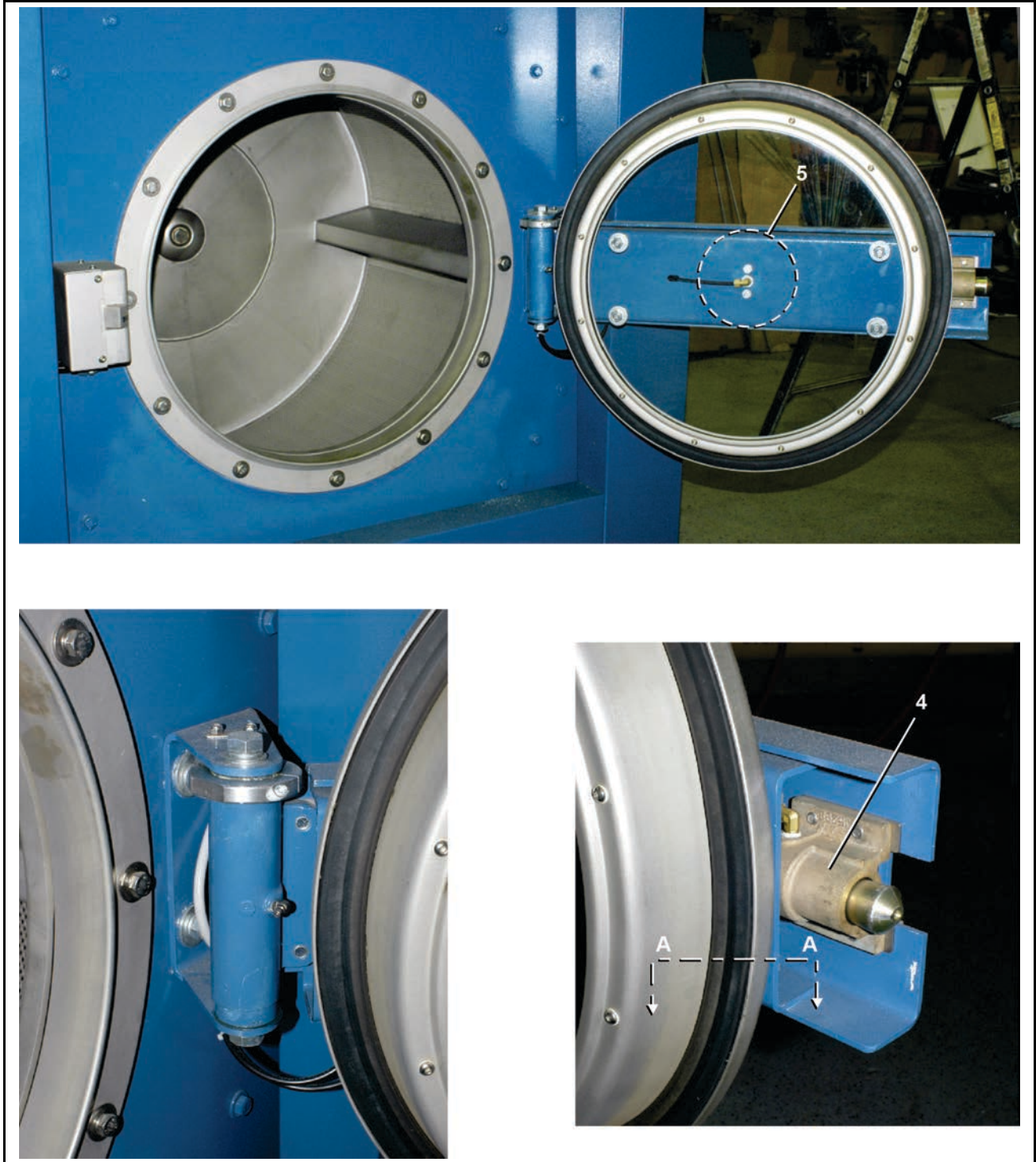

## 26" Door

4 Sheets

MWF63J7, MWF63Z7, MWF77J7, MWF77Z7, MWF63C7, MWF63Y7, MWF77C7, MWF77Y7

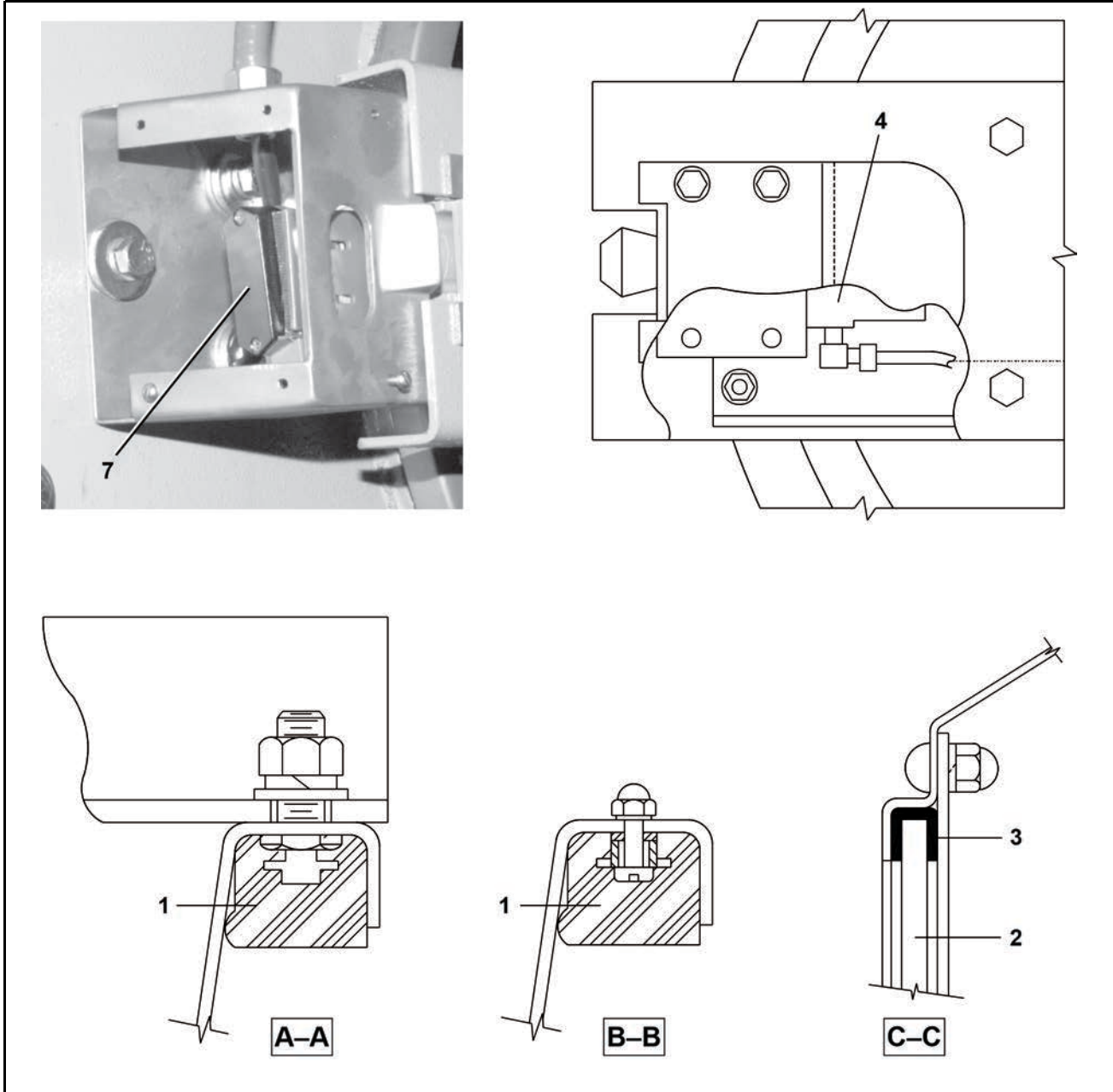

**26" Door**

4 Sheets

MWF63J7, MWF63Z7, MWF77J7, MWF77Z7, MWF63C7, MWF63Y7, MWF77C7, MWF77Y7

**Table 22. Parts List—Installation 26" Door**

Find the assembly for your machine and the letter shown in the "Item" column. The components for your machine will show this letter or the word "all" in the "Used In" column. The numbers shown in the "Item" column are those shown in the illustrations.				
Used In	Item	Part Number	Description/Nomenclature	Comments
Components				
all	1	03 48152	DOOR GASKET RING 26" DOOR	
all	2	98CX48050	DOOR GLASS=26" OPENING, X/MWF	
all	3	98CX48052	GASKET=DR GLASS 26" OPENING	
all	4	98CX15028	DOOR LATCH ASSY-DIVCYLS	
all	5	60B090	AIRMT S-131 1CONV	
all	6	09RM01212S	CAPSW 12' 180DEG ROLLER SILVER	
all	7	98CX965312	TEND TZ-6101	

BPWMBD02 / 2022354

BPWMBD02.1 0000410502 G.2 B.2 8/24/22, 6:26 PM Released

**Door Latch**

1 Sheet

MWF36J8, MWF36Z8; MWF45J8, MWF45Z8; MWF63J7, MWF63Z7; MWF77J7, MWF77Z7; MWF63C7, MWF63Y7; MWF77C7, MWF77Y7

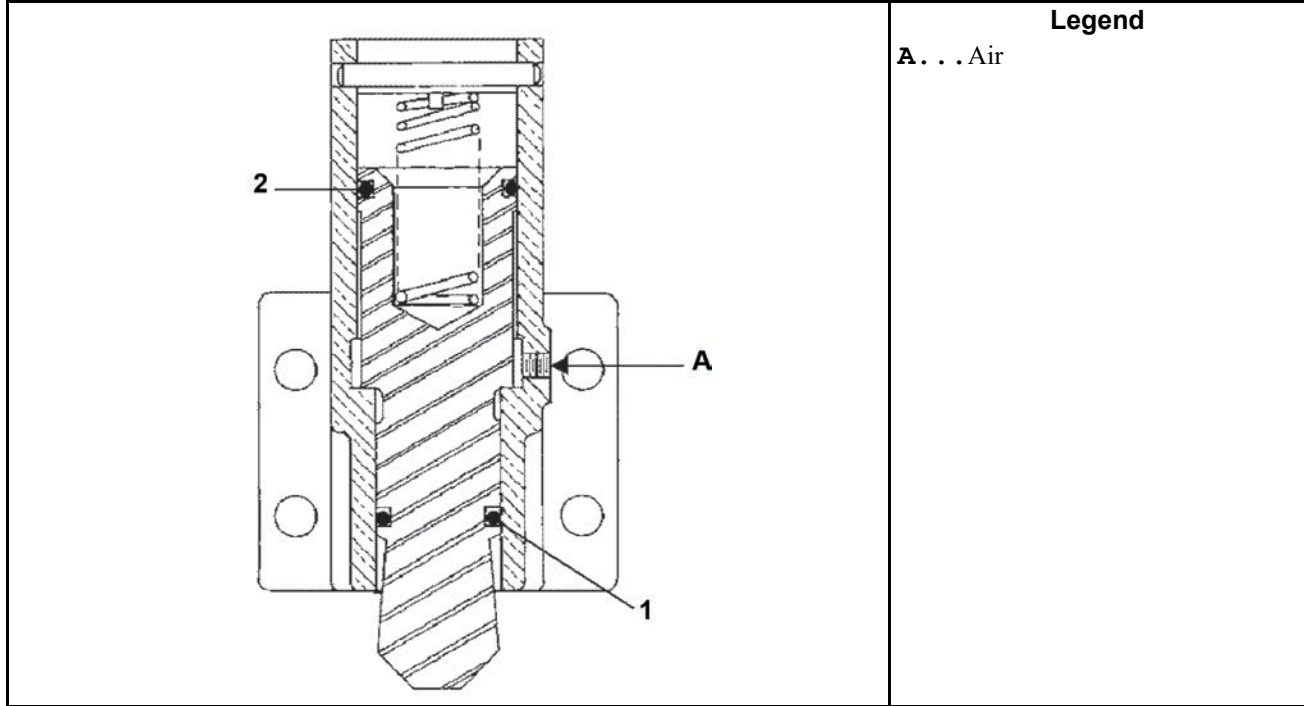

**Legend**

A . . . Air

**Table 23. Parts List—Door Latch**

Find the assembly for your machine and the letter shown in the "Item" column. The components for your machine will show this letter or the word "all" in the "Used In" column. The numbers shown in the "Item" column are those shown in the illustrations.

Used In	Item	Part Number	Description/Nomenclature	Comments
Components				
all	1	60C122	ORING 1"IDX1/8CS BUNA70 #214	
all	2	60C128	ORING 1+3/8IDX1/8CS BUNA70#220	

# 7 Chemical Supply

BPWMB01 / 2022354

BPWMB01.1 0000410689 G.2 B.2 8/24/22, 6:45 PM Released

# Soap Chute

2 Sheets

MWF36J8, MWF36Z8; MWF45J8, MWF45Z8; MWF63J7, MWF63Z7; MWF77J7, MWF77Z7; MWF63C7, MWF63Y7; MWF77C7, MWF77Y7

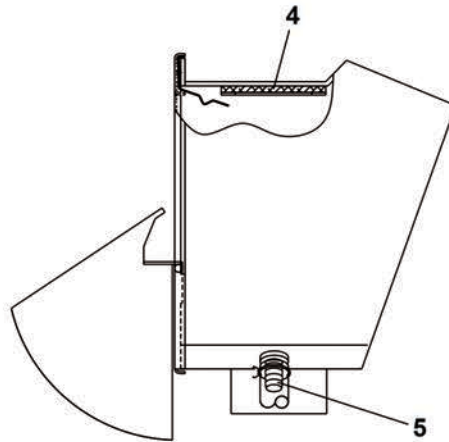

**Soap Chute**

2 Sheets

MWF36J8, MWF36Z8; MWF45J8, MWF45Z8; MWF63J7, MWF63Z7; MWF77J7, MWF77Z7; MWF63C7, MWF63Y7; MWF77C7, MWF77Y7

**Table 24. Parts List—Soap Chute**

Find the assembly for your machine and the letter shown in the "Item" column. The components for your machine will show this letter or the word "all" in the "Used In" column. The numbers shown in the "Item" column are those shown in the illustrations.				
Used In	Item	Part Number	Description/Nomenclature	Comments
Components				
all	1	AWS30211A	PLASTIC SOAP ASSY	
all	2	02 03870D	FLEXTUBE=2"ID X 14"LG W/CUFFS	
all	0	98CX873160	FLEXIBLE HOSE ID13XOD20X44M	
all	4	98CX972828	PAD=PLASTIC SOAPCHUTE	
all	5	51BB0KN00B	BULKHD FITT 1/2"BARBED,POLYPRO	





# Peristaltic Supply

2 Sheets

MWF36J8, MWF36Z8; MWF45J8, MWF45Z8; MWF63J7, MWF63Z7; MWF77J7, MWF77Z7; MWF63C7, MWF63Y7; MWF77C7, MWF77Y7.

Figure 11. Peristaltic Inlet

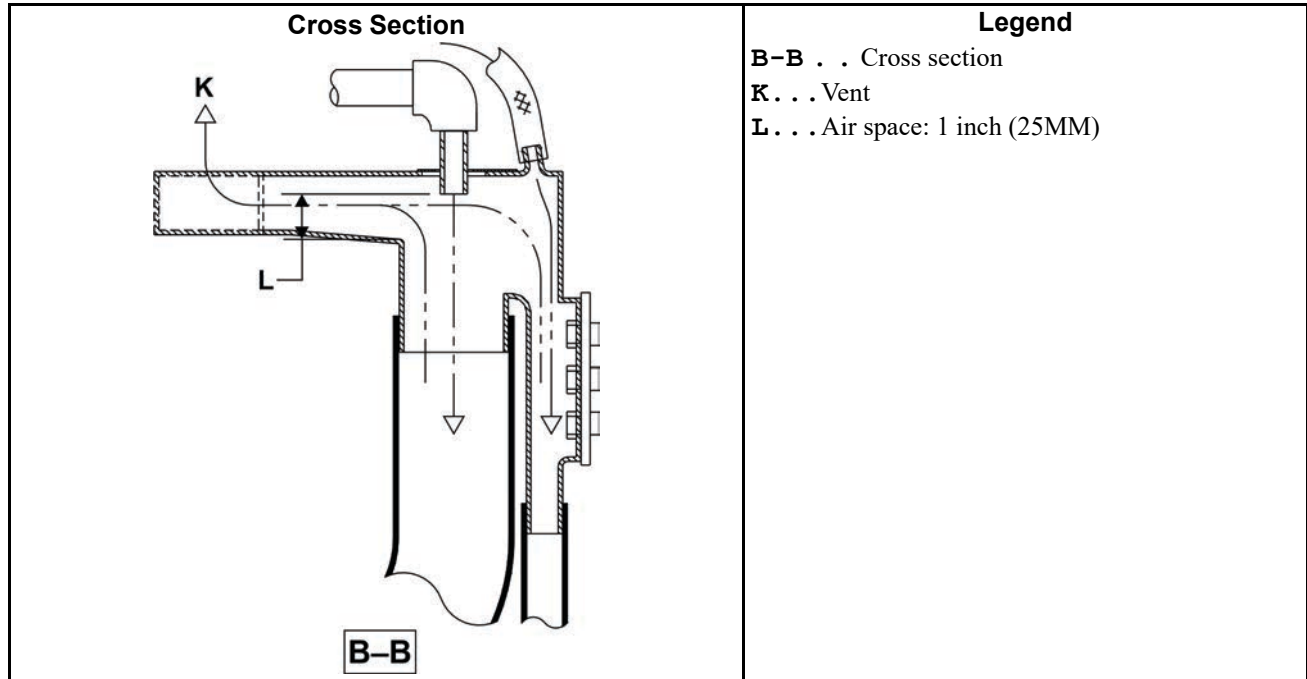

Table 25. Parts List—Peristaltic Supply

Find the assembly for your machine and the letter shown in the "Item" column. The components for your machine will show this letter or the word "all" in the "Used In" column. The numbers shown in the "Item" column are those shown in the illustrations.				
Used In	Item	Part Number	Description/Nomenclature	Comments
Components				
all	1	02 03588M	PERISTALTIC/WATER INLET 3022H	
all	2	98CX489021	NPT PLASTIC PLUG,3/8	
all	3	98CX03588X	WATER INLET/PERISTALTIC HOSE,30X/36X/42X	
all	4	27A088S	HOSECLAMP 3+1/16-4"SSSCR#HSS56	
all	5	98CX873160	FLEXIBLE HOSE ID13XOD20X44M	
all	6	98CX910816	FLEXIBLE HOSE ID25XOD34X44M	

BPWMBC03 / 2022354

BPWMBC03.1 0000410771 G.2 B.2 8/24/22, 6:53 PM Released

## 5 Compartment Supply

2 Sheets

MWF36J8, MWF36Z8; MWF45J8, MWF45Z8; MWF63J7, MWF63Z7; MWF77J7, MWF77Z7; MWF63C7, MWF63Y7; MWF77C7, MWF77Y7

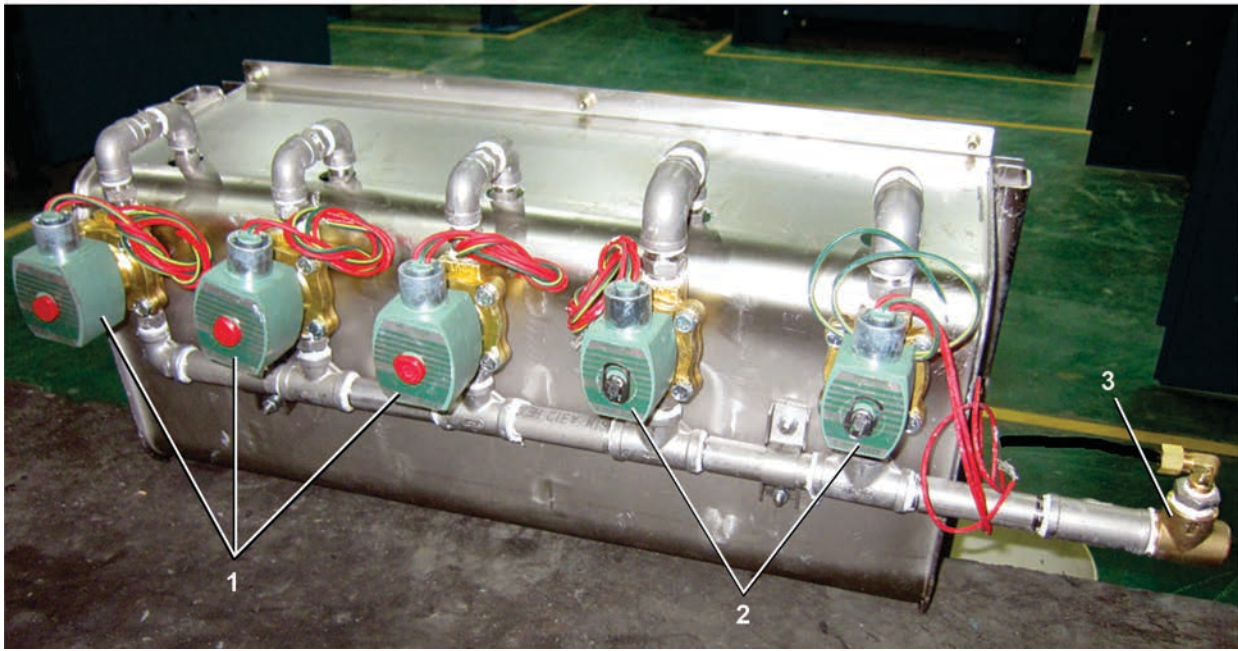
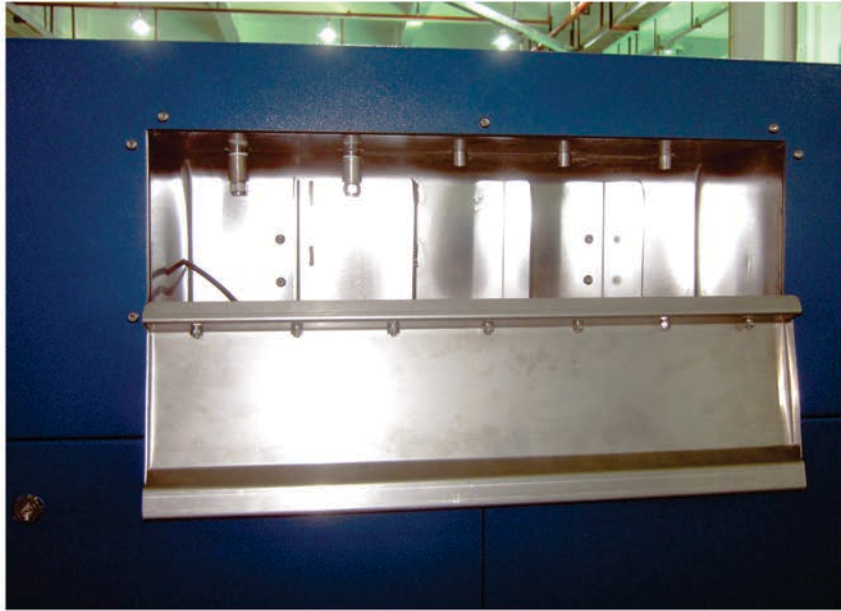

## 5 Compartment Supply

2 Sheets

MWF36J8, MWF36Z8; MWF45J8, MWF45Z8; MWF63J7, MWF63Z7; MWF77J7, MWF77Z7; MWF63C7, MWF63Y7; MWF77C7, MWF77Y7



**Table 26. Parts List—5 Compartment Supply**

Find the assembly for your machine and the letter shown in the "Item" column. The components for your machine will show this letter or the word "all" in the "Used In" column. The numbers shown in the "Item" column are those shown in the illustrations.				
Used In	Item	Part Number	Description/Nomenclature	Comments
Components				
all	1	96TCC2AA71	3/8" N/C 2WAY 240V50/60C VALVE	
all	2	96TDC2AA71	1/2"N/C2WY240V50/60C VLV(DRYVC)	
all	3	96M001	1/2X3/8" RELIEF VALVE SET31#	
all	4	02 03870D	FLEXTUBE=2"ID X 14"LG W/CUFFS	

# 8 Water and Steam

BPWMCW01 / 2023194A

BPWMCW01.1 0000420008 G.2 C.2 5/11/23, 3:05 PM Released

**Water and Steam**

3 Sheets

MWF63J7, MWF63Z7, MWF63C7, MWF63Y7, MWF77J7, MWF77Z7, MWF77C7, MWF77Y7

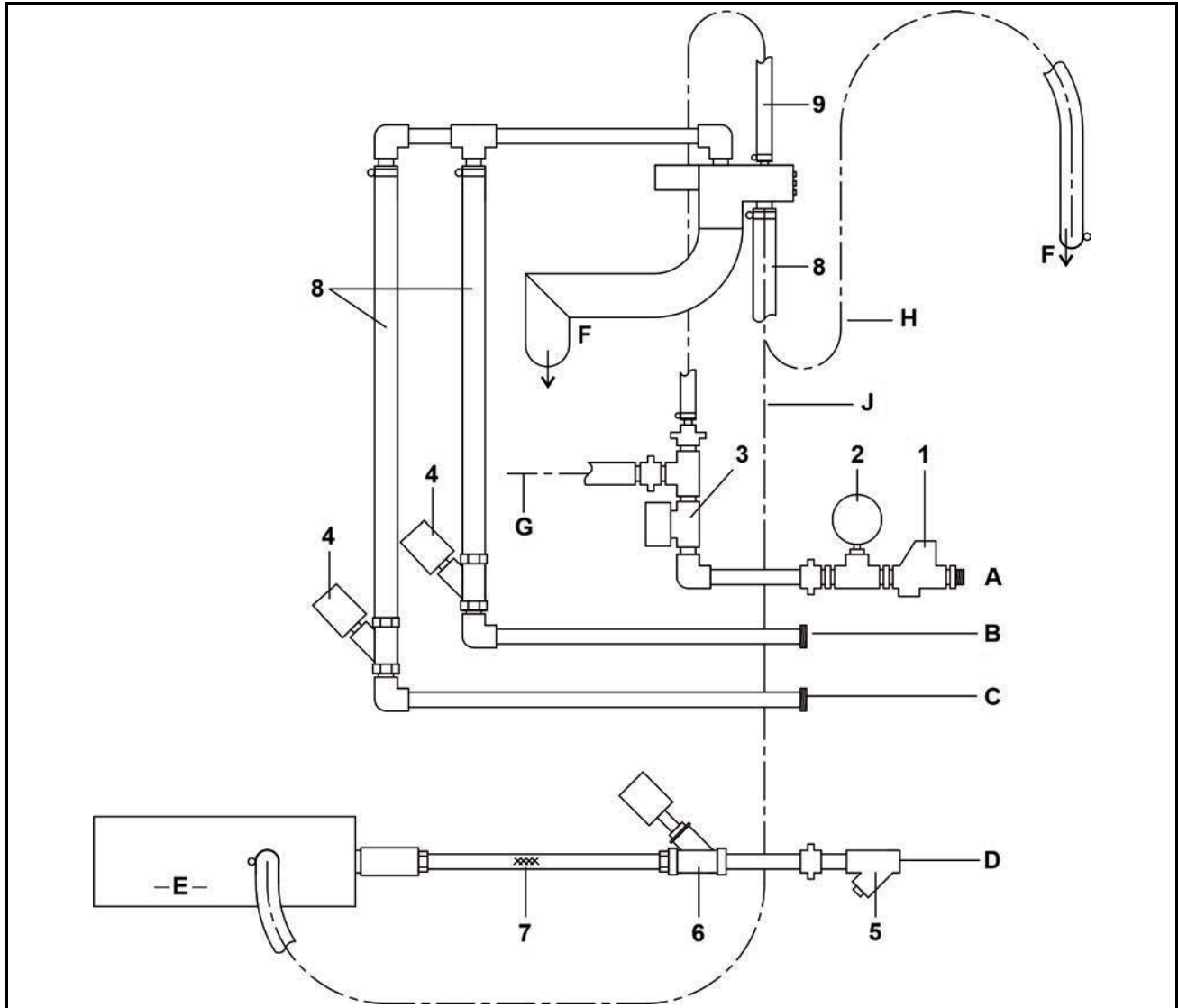

**Legend**

- A . . . Hot water for supply
- B . . . Hot
- C . . . Cold
- D . . . Steam
- E . . . Drain trough
- F . . . To shell
- G . . . To soap chute or 5 compartment supply
- H . . . Tilt models
- J . . . Non-tilt models

## Water and Steam

3 Sheets

MWF63J7, MWF63Z7, MWF63C7, MWF63Y7, MWF77J7, MWF77Z7, MWF77C7, MWF77Y7

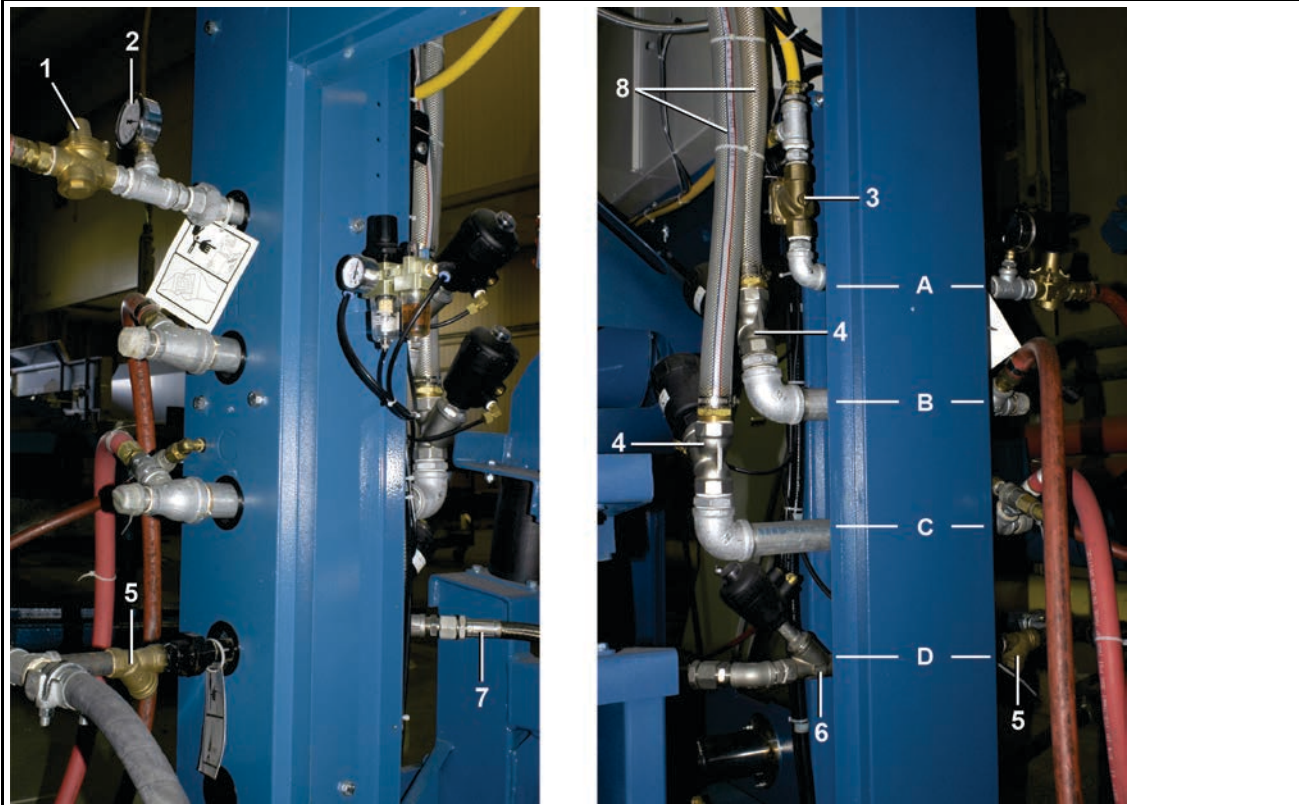

### Legend

- A . . . Hot water for supply
- B . . . Hot
- C . . . Cold
- D . . . Steam

**Water and Steam**

3 Sheets

MWF63J7, MWF63Z7, MWF63C7, MWF63Y7, MWF77J7, MWF77Z7, MWF77C7, MWF77Y7

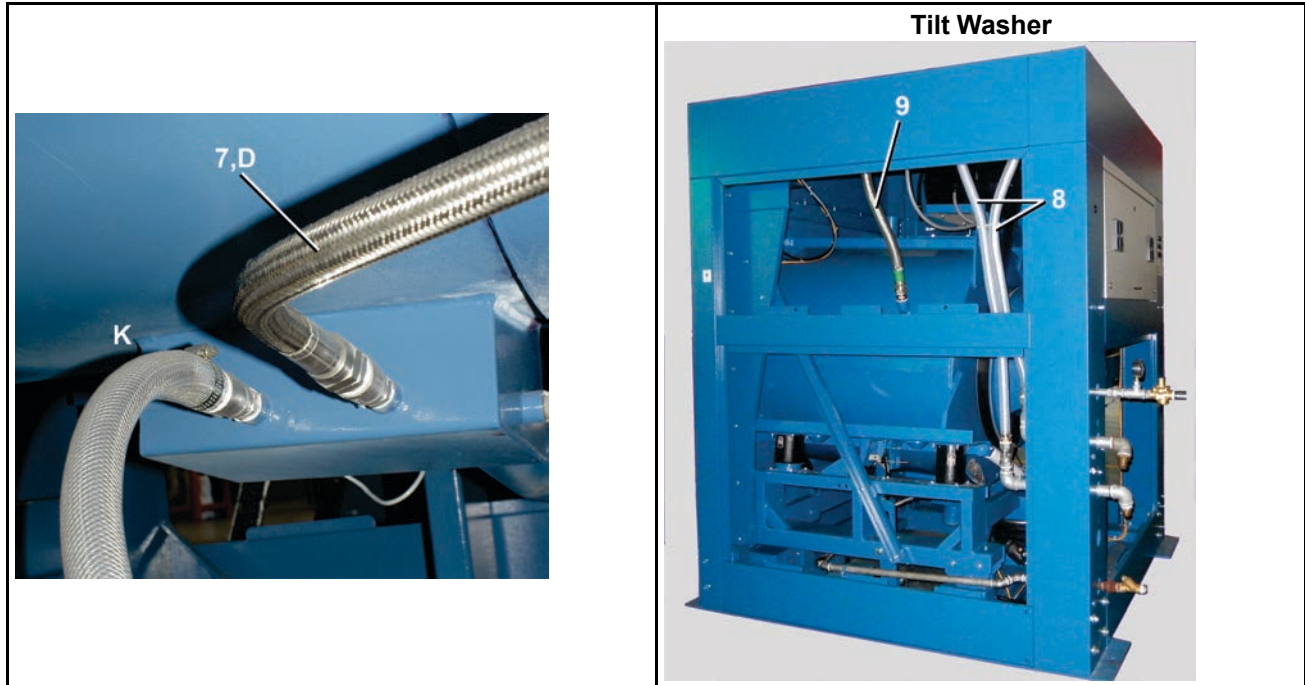

**Legend**

- D . . . Steam
- K . . . Water from peristaltic

**Table 27. Parts List—Water & Steam**

Find the assembly for your machine and the letter shown in the "Item" column. The components for your machine will show this letter or the word "all" in the "Used In" column. The numbers shown in the "Item" column are those shown in the illustrations.

Used In	Item	Part Number	Description/Nomenclature	Comments
Reference Assemblies				
	A		NON-TILT MODELS	MWF63J7, MWF63Z7 MWF77J7, MWF77Z7
	B		TILT MODELS	MWF63C7, MWF63Y7 MWF77C7, MWF77Y7
Components				
all	1	98CX820820	PRESSURE REGULATOR, 3/4 28PSI	
all	2	98CX902450	PRESSGAUGE R1/4",0-28PSI	
all	3	96P063B71	3/4"NC 230V 50/60 W/DIN CON PARKER 12F24C2248AAFPH15	
all	4	96D086WE	ANGBODVLV 1.25"NC H20 BRZ	
all	5	98CX820606	Y-STRAINER, 3/4"	
all	6	96D0009E	3/4"NPTBRZ N/C STEAMVAL ANGBOD	
all	7	98MW800406	STEAM HOSE, 3/4X730	
all	8	98CX910816	FLEXIBLE HOSE ID25XOD34X44M	
all	9	98MW489317	WATER INLET HOSE 1.25X39.37", MWF77C7	

BPWM2W01 / 2022354

BPWM2W01.1 0000410578 G.2 B.2 8/24/22, 6:36 PM Released

## Drain Valve to Rear

1 Sheet

MWF36J8, MWF36Z8; MWF45J8, MWF45Z8; MWF63J7, MWF63Z7; MWF77J7, MWF77Z7

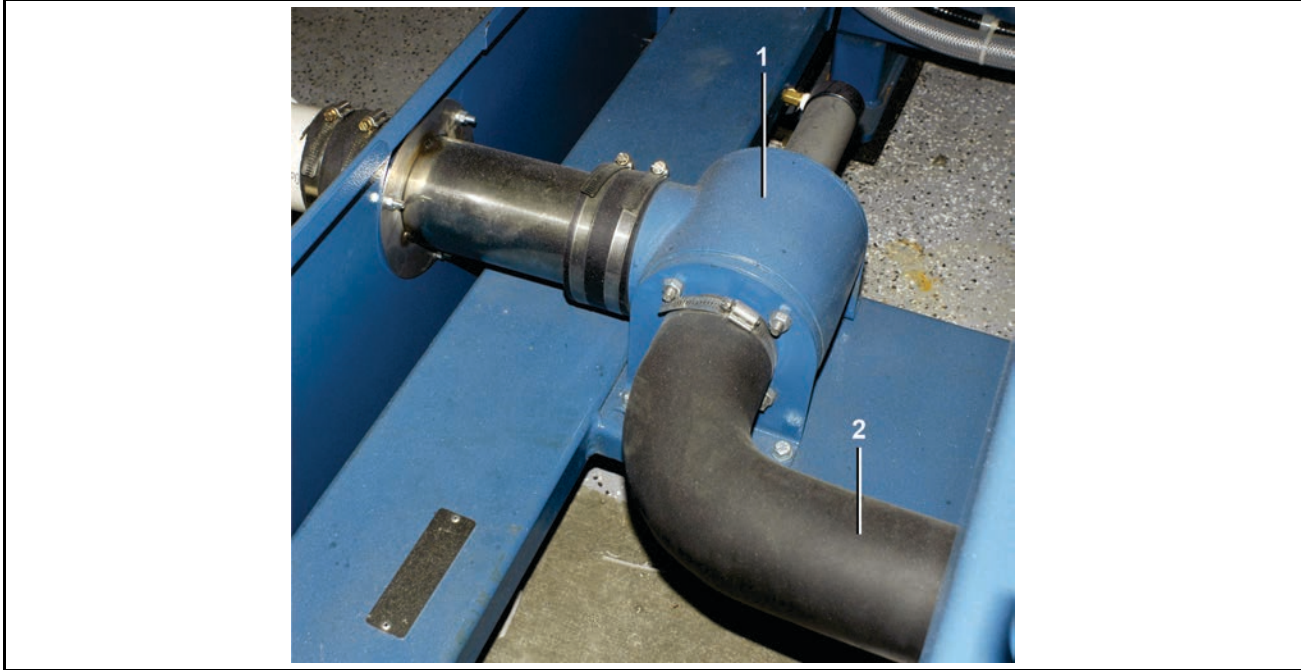

**Table 28. Parts List—Drain Valve to Rear**

Find the assembly for your machine and the letter shown in the "Item" column. The components for your machine will show this letter or the word "all" in the "Used In" column. The numbers shown in the "Item" column are those shown in the illustrations.				
Used In	Item	Part Number	Description/Nomenclature	Comments
Components				
all	1	98MW3604	PNEUMATIC DRAIN VALVE WMF	
all	2	98CX03588C	DRAIN HOSE 3.06IDX.13WALL, 42X CSM	



# 9 Pneumatic Assemblies

**Pneumatic Schematic**

MWF63J7, MWF63Z7, MWF77J7, MWF77Z7

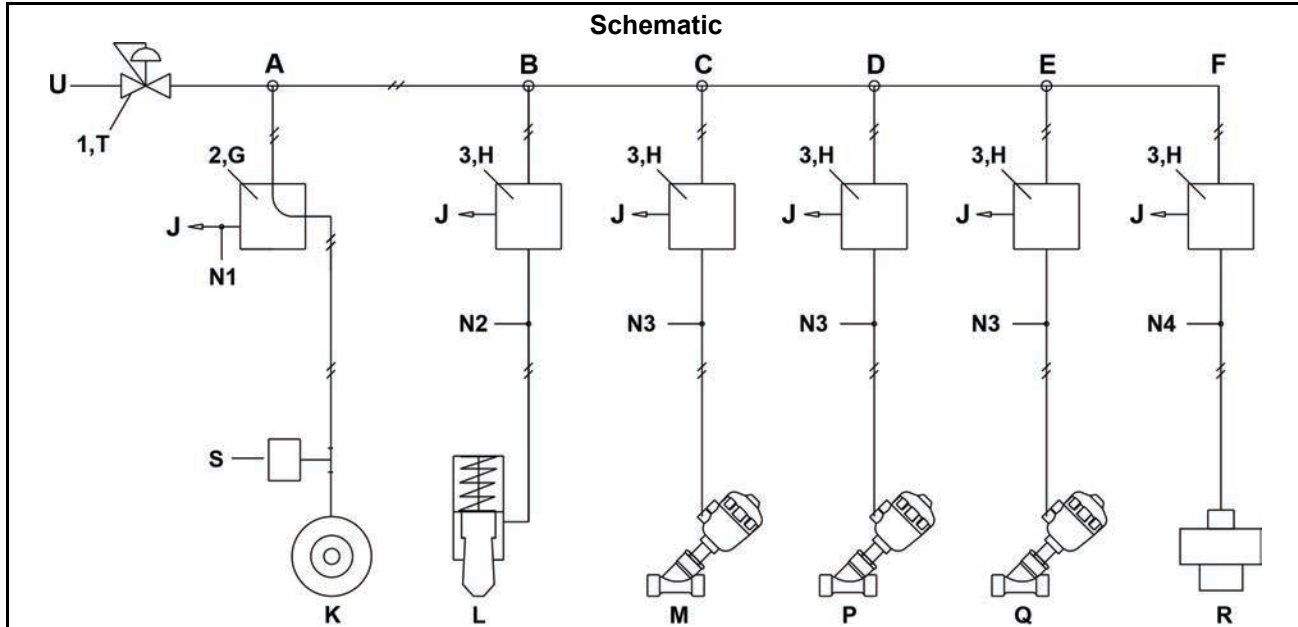

**Legend**

- A . . . Door seal
- B . . . Door latch
- C . . . Hot water line
- D . . . Cold water line
- E . . . Steam line
- F . . . Drain line
- G . . . Usually open
- H . . . Usually closed
- J . . . Exhaust
- K . . . Pneumatic bellows actuator
- L . . . Door latch
- M . . . Hot water valve, air operated
- N1 . . The door seals are deflated when the pilot valve is energized.
- N2 . . The spring locks the door closed latch. The door closed latch is opened when the pilot valve is energized.
- N3 . . The steam valve is opened when the pilot valve is energized.
- N4 . . The drain valve is opened when the pilot valve is energized.
- P . . . Cold water valve, air operated
- Q . . . Steam valve, air operator
- R . . . Drain valve, air operated
- S . . . Pressure switch
- T . . . Air regulator
- U . . . Compressed air, 85-125PSI (5.8-8.5 ATU)

**Pneumatic Schematic**

2 Sheets

MWF63J7, MWF63Z7, MWF77J7, MWF77Z7

**Table 29. Parts List—Pneumatic Schematic**

Find the assembly for your machine and the letter shown in the "Item" column. The components for your machine will show this letter or the word "all" in the "Used In" column. The numbers shown in the "Item" column are those shown in the illustrations.				
Used In	Item	Part Number	Description/Nomenclature	Comments
Components				
all	1	98CX880511	CSM AIR REGULATOR G1/4 W/O GAGE	
all	2	96R301B71	1/8" AIRPILOT 3W NC 240V50/60	
all	3	96R302B71	1/8" AIRPILOT 3W NO 240V50/60	

# 10 Control and Sensing

BPWMBZ01 / 2022062

BPWMBZ01.1 0000407434 G.2 A.3 1/31/22, 1:43 PM Released

# Water Level & Temperature Sensor

1 Sheet

MWF45J8/Z8, MWF63J7/Z7, MWF77J7/Z7, MWF100J7/Z7, MWF125J7/Z7; MWF45C8/Y8, MWF63C7/Y7, MWF77C7/Y7, MWF100C7/Y7, MWF125C7/Y7

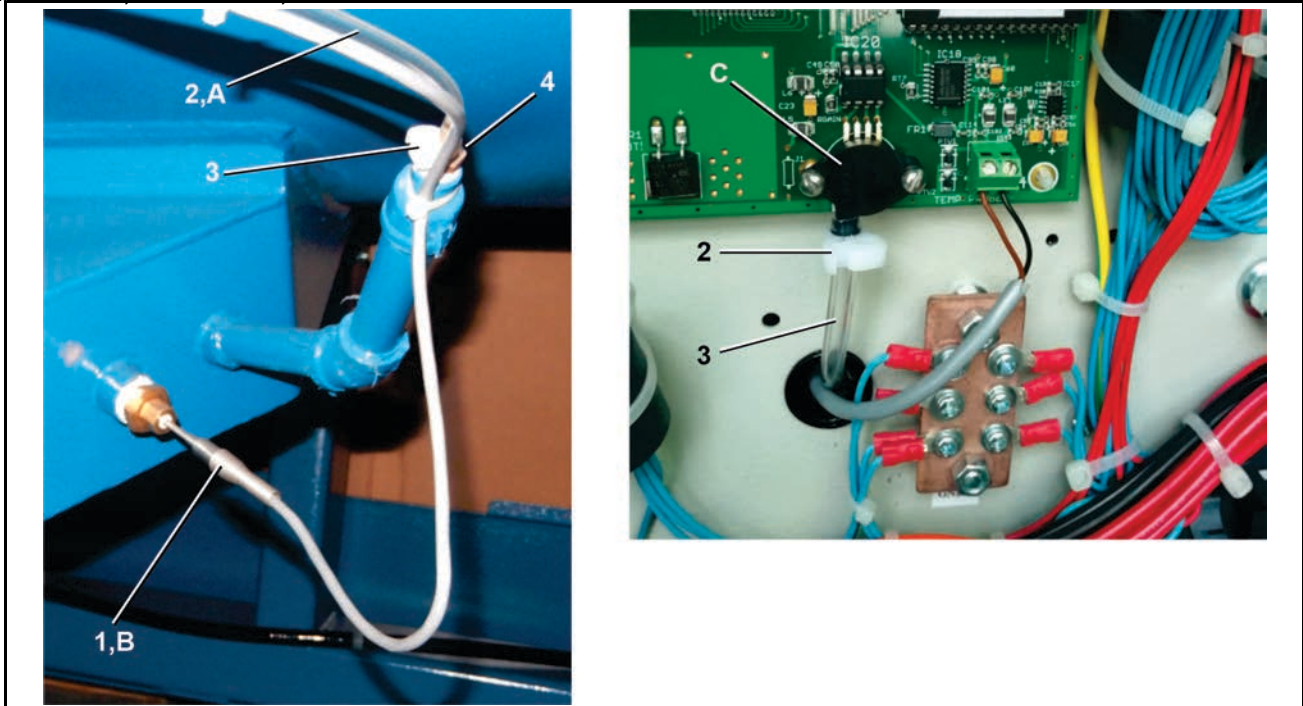

### Legend

- A . . . To transducer
- B . . . Temperature probe
- C . . . Transducer

**Table 30. Parts List—Water Level & Temperature Sensor**

Find the assembly for your machine and the letter shown in the "Item" column. The components for your machine will show this letter or the word "all" in the "Used In" column. The numbers shown in the "Item" column are those shown in the illustrations.				
Used In	Item	Part Number	Description/Nomenclature	Comments
Reference Assemblies				
	A		REFERENCE	E-P Plus® MODELS, MWF45J8/C8, MWF63J7/C7, MWF77J7/C7, MWF100J7/C7, MWF125J7/C7
	B		REFERENCE	MilTouch™ MODELS, MWF45Z8/Y8, MWF63Z7/Y7, MWF77Z7/Y7, MWF100Z7/Y7, MWF125Z7/Y7
Components				
all	1	30R0043PB	TEMPERATURE PROBE ASSY=BRASS	
A	2	60E004NT	TUBING (NYL.)CLR.1/4"ODX1/8"	
B	2	60E004NA	TUBING CLEAR PVC 3/16"IDX5/16"OD	
A	3	27A047	HOSECLMP 1/8HOSEID CLIP#5000-2	
B	3	27A047A	HOSE CLAMP 5/16" NOMINIAL MIN .256", MFG#5700149	

**Water Level & Temperature Sensor**

1 Sheet

MWF45J8/Z8, MWF63J7/Z7, MWF77J7/Z7, MWF100J7/Z7, MWF125J7/Z7; MWF45C8/Y8, MWF63C7/Y7,  
MWF77C7/Y7, MWF100C7/Y7, MWF125C7/Y7

**Table 30 Parts List—Water Level & Temperature Sensor (cont'd.)**

Find the assembly for your machine and the letter shown in the "Item" column. The components for your machine will show this letter or the word "all" in the "Used In" column. The numbers shown in the "Item" column are those shown in the illustrations.				
Used In	Item	Part Number	Description/Nomenclature	Comments
A	4	98CX932420	HOSESTEM BRASS 1/4"BSP X 1/8"HOSE ID	
B	4	98CX932420A	HOSESTEM BRASS 1/4"BSP X 3/16"HOSE ID	

# 11 Dimensional Drawings

This page intentionally blank



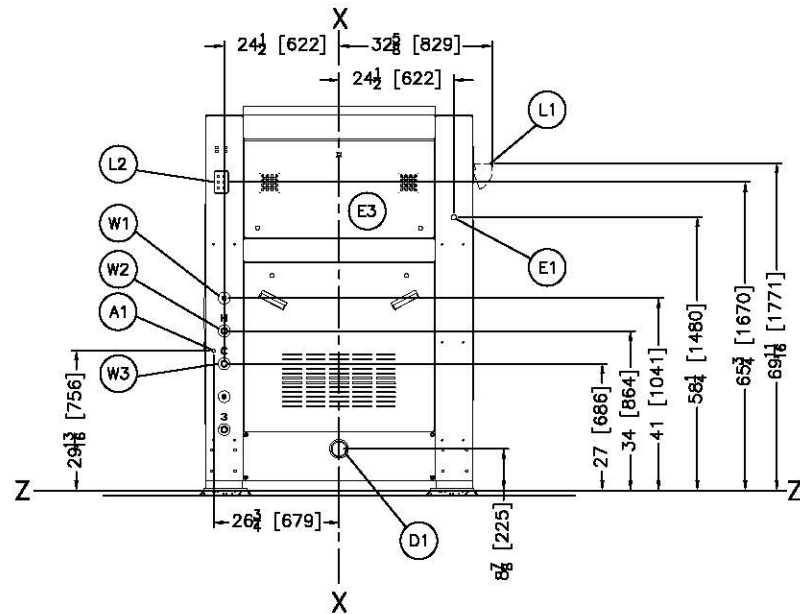
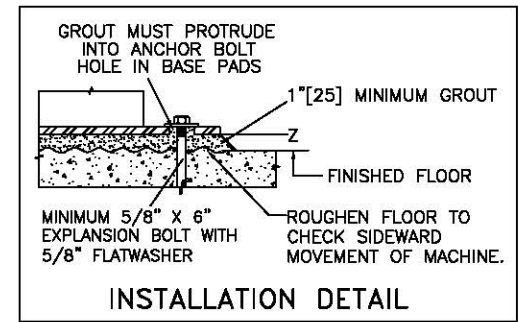

REAR VIEW

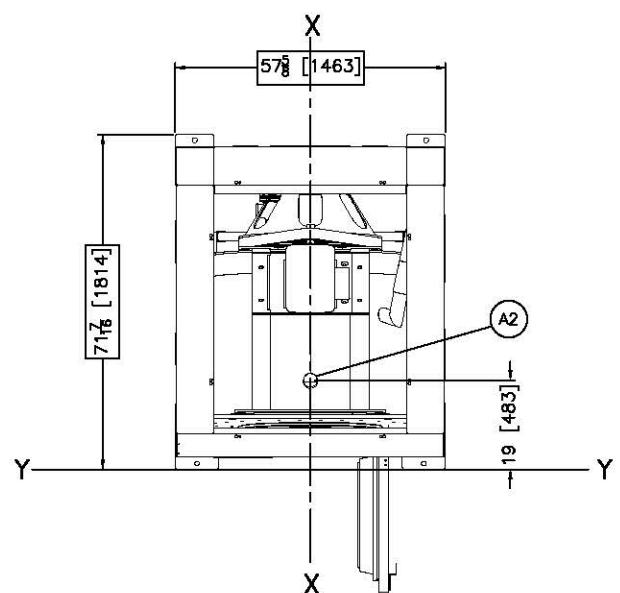

PLAN VIEW

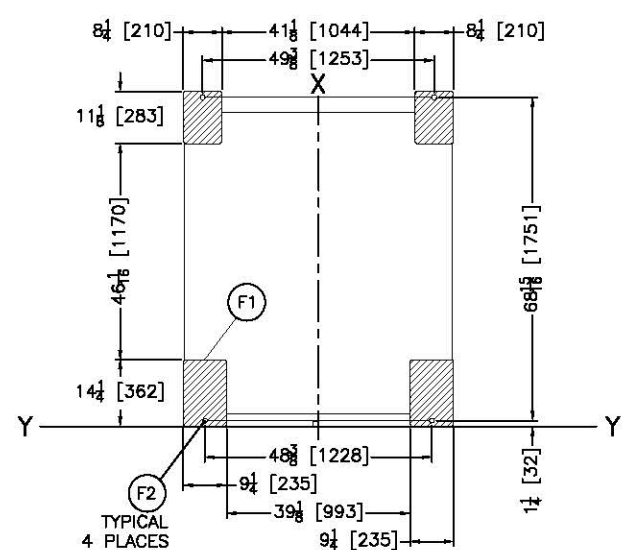

FOUNDATION PLAN

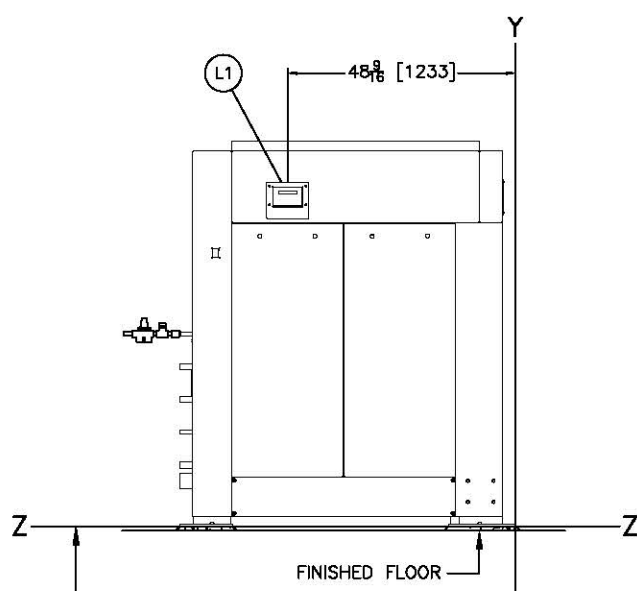

LEFT VIEW

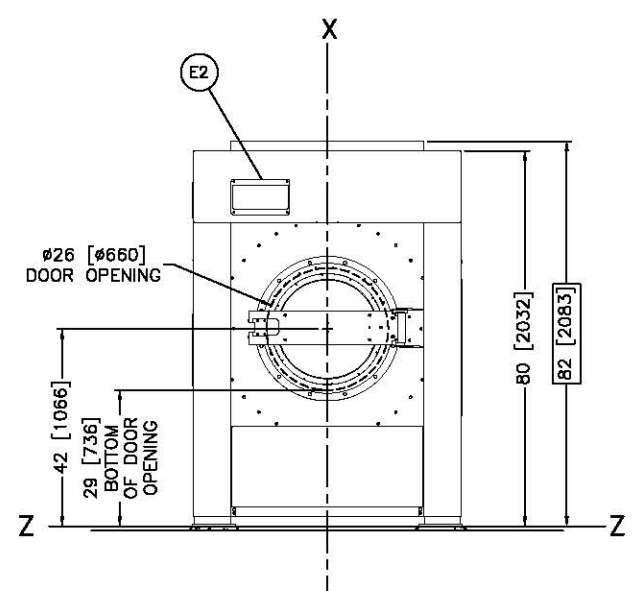

FRONT VIEW

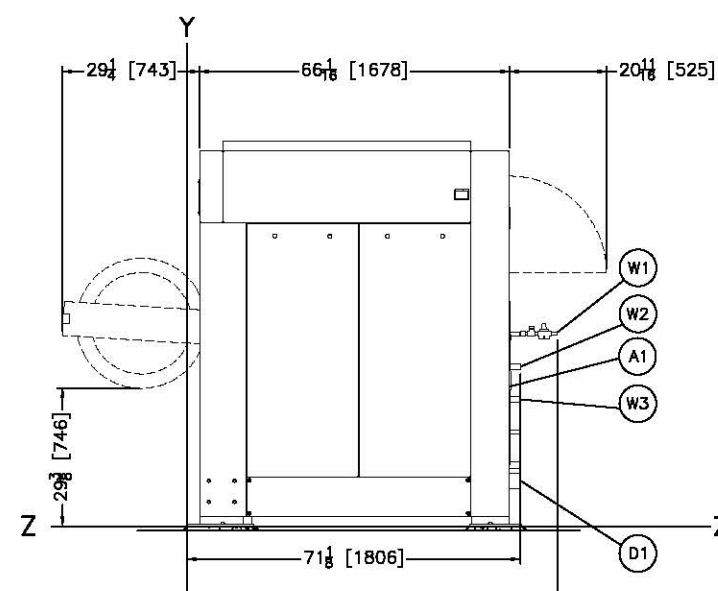

RIGHT VIEW

ITEM	LEGEND
W3	COLD WATER INLET, 1-1/4" NPT CONNECTION
W2	HOT WATER INLET, 1-1/4" NPT CONNECTION
W1	HOT WATER FOR SUPPLY, 3/4" NPT CONNECTION, PRESSURE REGULATOR ASSEMBLY, REMOVED FOR SHIPPING, MUST BE ADDED AT INSTALLATION.
L3	ADDITIONAL LIQUID SUPPLY INLETS FOR 15 PORT PERISTALTIC MWF63Z7 MODELS ONLY.
L2	STANDARD LIQUID SUPPLY INLETS, SEE NOTE 10.
L1	STANDARD SOAP CHUTE
F2	(4) 1-1/16" DIAMETER ANCHOR BOLT HOLES, USE 5/8" X 6" BOLTS MINIMUM.
F1	BASEPADS, SEE NOTE 8.
E3	MICROPROCESSOR CONTROL BOX
E2	E-P Plus® Controller - MWF63J7 MODELS, MiiTouch™ Controller - MWF63Z7 MODELS
E1	MAIN ELECTRICAL CONNECTION
D1	DRAIN TO REAR, AIR OPERATED, 3" PIPE SOCKET JOINT
A3	CHEMICAL SUPPLY VENT
A2	VENT, 3" O.D. DIAMETER
A1	MAIN AIR, 1/4" NPT CONNECTION, CUSTOMER MUST SUPPLY AIR STRAINER.

- NOTES**
- 11 12" [305] MINIMUM CLEARANCE IS RECOMMENDED FOR SERVICE TO MACHINE ON SIDES NOT REQUIRING OPERATOR ACCESS. 18" [468] MINIMUM IS RECOMMENDED FOR OPERATOR ACCESS TO SOAP SUPPLY. SEE LOCAL ELECTRIC CODES FOR REQUIRED CLEARANCES.
  - 10 STANDARD LIQUID SUPPLY INLETS COMES WITH THREE SETS OF FIVE FITTINGS, ONE SET OF 3/8" FITTINGS, ONE SET OF 1/2" FITTINGS, AND ONE SET OF PLUGS WHICH ARE SHIPPED ON MACHINE.
  - 9 SHIM TO LEVEL THE MACHINE AND ALLOW FOR 1" [25] MINIMUM GROUT. ANCHOR ALL LABELED ANCHOR BOLT HOLES. USE 5/8" X 6" BOLTS, MINIMUM. SEE INSTALLATION MAINTENANCE MANUAL FOR FURTHER INSTRUCTIONS.
  - 8 SHADED AREA DENOTES BASE PADS WHICH MUST BE CONTINUOUSLY SUPPORT.
  - 7 DO NOT PRE-PIPE ANY CLOSER THAN 60 [1524].
  - 6 AS OF THIS WRITING, THE MINIMUM CLEARANCE REQUIRED BY U.S. NATIONAL ELECTRIC CODES, FROM ELECTRIC BOX TO ANY OBJECT IS:  
36 [914] IF OBJECT IS AN UNGROUNDED (INSULATED) WALL.  
42 [1067] IF OBJECT IS A GROUNDED WALL (e.g. BARE CONCRETE, BRICK, ETC.)  
48 [1219] IF OBJECT IS ANY LIVE PART.  
CHECK LOCAL ELECTRIC CODES FOR FURTHER RESTRICTIONS.
  - 5 CUSTOMER TO SUPPLY CIRCUIT BREAKER OR FUSED BRANCH CIRCUIT DISCONNECT (SAFETY) SWITCHES WITH LAG TYPE FUSES FROM POWER SOURCE TO MACHINE. A SEPARATE GROUND WIRE MUST BE CONNECTED FROM DISCONNECT TO EQUIPMENT.
  - 4 BASELINE "Z" IS THE SAME FOR ALL MILNOR MACHINES AND IS SHOWN ON ALL DIMENSIONAL DRAWINGS. THE DISTANCE BETWEEN BASELINE "Z" AND THE FINISHED FLOOR MAY VARY (WITH CHANGES IN FLOOR HEIGHT) AS REQUIRED TO INSURE THAT BASELINE "Z" IS HORIZONTAL AND ALL COMPONENTS REQUIRING GROUT ARE SET ON A MINIMUM 1" [25] THICK GROUT BED.
  - 3 USE REFERENCE LINES "X", "Y", AND "Z" TO LOCATE ALL SERVICE CONNECTIONS.
  - 2 NUMBERS IN BRACKETS [ ] DENOTE DIMENSIONS IN MILLIMETERS.
  - 1 ALL DIMENSIONS SHOWN ARE APPROXIMATE, SUBJECT TO NORMAL MANUFACTURING TOLERANCES, AND TO OCCASIONAL CHANGES WITHOUT NOTICE THROUGH REDESIGN AND/OR RELOCATION OF COMPONENTS, ETC. DO NOT USE FOR CONSTRUCTION UNLESS CERTIFIED, AND IN NO EVENT PRE-PIPE CLOSER THAN FIVE FEET FROM MACHINE. FACTORY MUST BE CONSULTED FOR DIMENSIONS IF MACHINE IS TO BE MOVED THROUGH NARROW OR LOW CORRIDORS OR OPENINGS.
- ATTENTION**  
MOST REGULATORY AUTHORITIES (INCLUDING OSHA IN THE USA) HOLD THE OWNER/USER ULTIMATELY RESPONSIBLE TO MAINTAIN A SAFE WORKING ENVIRONMENT. ACCORDINGLY, THE OWNER/USER MUST RECOGNIZE ALL FORESEEABLE SAFETY HAZARDS, FURNISH SAFETY INSTRUCTIONS AND GUIDANCE TO ALL PERSONNEL WHO MAY COME IN CONTACT WITH THE INSTALLATION, AND PROVIDE ALL NECESSARY ADDITIONAL SAFETY GUARDS, FENCES, RESTRAINTS, DEVICES, ETC., NOT FURNISHED BY THE EQUIPMENT MANUFACTURER OR VENDOR.
- ATTENTION**  
THE FLOOR AND/OR OTHER SUPPORT COMPONENTS MUST HAVE SUFFICIENT STRENGTH (AND RIGIDITY WITH DUE CONSIDERATION FOR NATURAL OR RESONANT FREQUENCY THEREOF) TO WITHSTAND THE FULLY LOADED WEIGHT OF THE MACHINE INCLUDING THE GOODS, THE WATER, AND ANY REPEATED SINUSOIDAL (ROTATING) FORCES GENERATED DURING ITS OPERATION. WRITE THE FACTORY FOR ADDITIONAL MACHINE DATA FOR USE BY A COMPETENT SOIL AND/OR STRUCTURAL ENGINEER.

BASELINE "Z" (REFERENCE FOR VERTICAL DIMENSIONS) CORRESPONDS TO TOP OF GROUT. SEE NOTE 3 AND 4.

REFERENCE LINE "Y" (REFERENCE FOR FRONT/REAR DIMENSIONS). SEE NOTE 3.

CENTERLINE "X" (REFERENCE FOR LEFT/RIGHT DIMENSIONS). SEE NOTE 3.

MWF63J7, MWF63Z7

P.O. Box 400 Kenner, LA 70063, USA, Phone 504/487-8981, FAX 504/488-3084, Email: milnorinfo@milnor.com

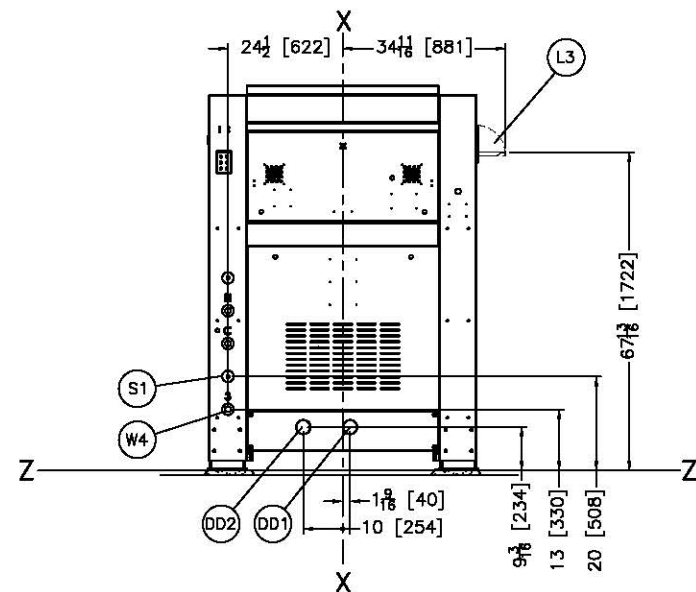

REAR VIEW

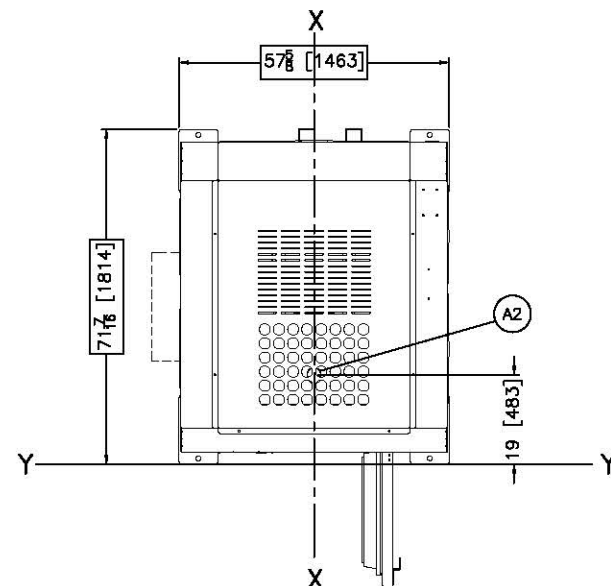

PLAN VIEW

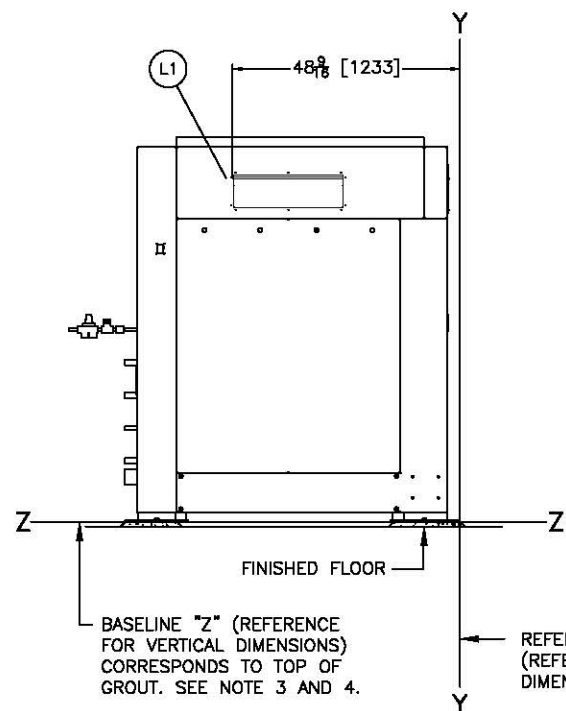

LEFT VIEW

BASELINE "Z" (REFERENCE FOR VERTICAL DIMENSIONS) CORRESPONDS TO TOP OF GROUT. SEE NOTE 3 AND 4.

REFERENCE LINE "Y" (REFERENCE FOR FRONT/REAR DIMENSIONS). SEE NOTE 3.

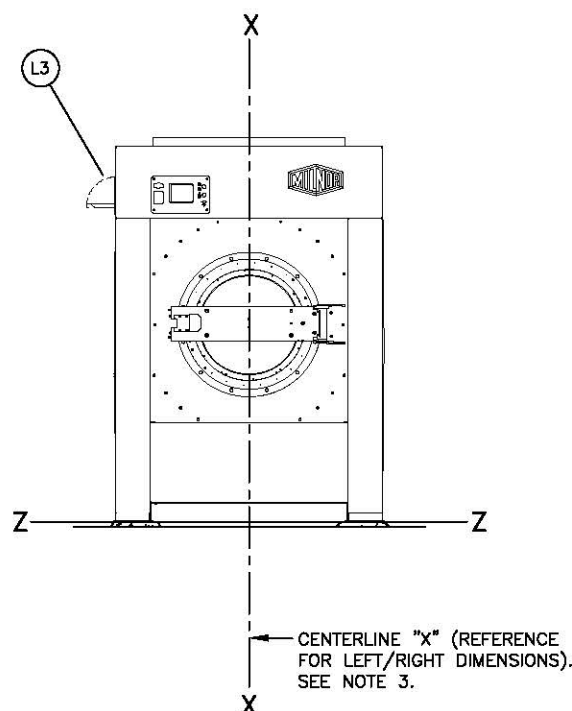

FRONT VIEW

CENTERLINE "X" (REFERENCE FOR LEFT/RIGHT DIMENSIONS). SEE NOTE 3.

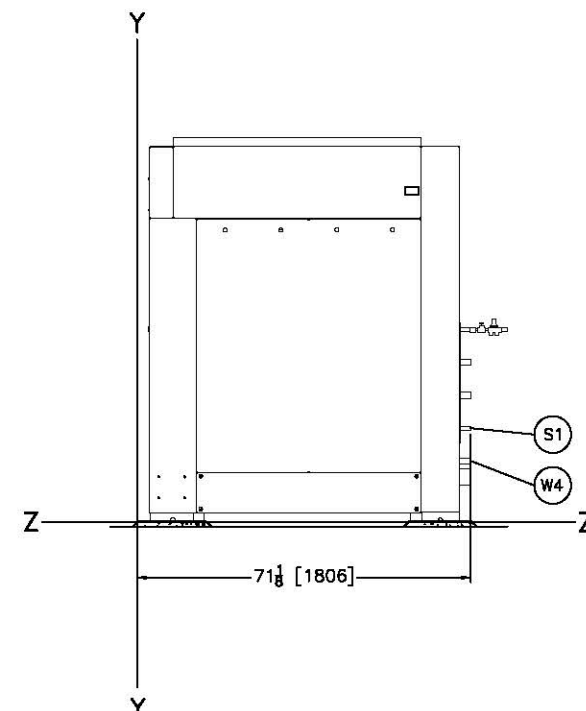

RIGHT VIEW

W4	OPTIONAL THIRD (REUSE) WATER INLET, 1-1/4" NPT CONNECTION
S1	OPTIONAL AIR-OPERATED STEAM INLET 3/4"NPT
L3	5 COMPARTMENT SUPPLY
DD2	DUAL DRAIN TO REUSE 3"[76] HOSE CONNECTION
DD1	DUAL DRAIN TO SEWER 3"[76] HOSE CONNECTION
ITEM	LEGEND

**NOTES**

6 AS OF THIS WRITING, THE MINIMUM CLEARANCE REQUIRED BY U.S. NATIONAL ELECTRIC CODES, FROM ELECTRIC BOX TO ANY OBJECT IS:  
 36 [914] IF OBJECT IS AN UNGROUNDED (INSULATED) WALL.  
 42 [1067] IF OBJECT IS A GROUNDED WALL (i.e. BARE CONCRETE, BRICK, ETC.).  
 48 [1219] IF OBJECT IS ANY LIVE PART.  
 CHECK LOCAL ELECTRIC CODES FOR FURTHER RESTRICTIONS.

5 CUSTOMER TO SUPPLY CIRCUIT BREAKER OR FUSED BRANCH CIRCUIT DISCONNECT (SAFETY) SWITCHES WITH LAG TYPE FUSES FROM POWER SOURCE TO MACHINE. A SEPARATE GROUND WIRE MUST BE CONNECTED FROM DISCONNECT TO EQUIPMENT.

4 BASELINE "Z" IS THE SAME FOR ALL MILNOR MACHINES AND IS SHOWN ON ALL DIMENSIONAL DRAWINGS. THE DISTANCE BETWEEN BASELINE "Z" AND THE FINISHED FLOOR MAY VARY (WITH CHANGES IN FLOOR HEIGHT) AS REQUIRED TO INSURE THAT BASELINE "Z" IS HORIZONTAL AND ALL COMPONENTS REQUIRING GROUT ARE SET ON A MINIMUM 1" [25] THICK GROUT BED.

3 USE REFERENCE LINES "X", "Y", AND "Z" TO LOCATE ALL SERVICE CONNECTIONS.

2 NUMBERS IN BRACKETS [ ] DENOTE DIMENSIONS IN MILLIMETERS.

1 ALL DIMENSIONS SHOWN ARE APPROXIMATE, SUBJECT TO NORMAL MANUFACTURING TOLERANCES, AND TO OCCASIONAL CHANGES WITHOUT NOTICE THROUGH REDESIGN AND/OR RELOCATION OF COMPONENTS, ETC. DO NOT USE FOR CONSTRUCTION UNLESS CERTIFIED, AND IN NO EVENT PRE-PIPE CLOSER THAN FIVE FEET FROM MACHINE. FACTORY MUST BE CONSULTED FOR DIMENSIONS IF MACHINE IS TO BE MOVED THROUGH NARROW OR LOW CORRIDORS OR OPENINGS.

**ATTENTION**  
 MOST REGULATORY AUTHORITIES (INCLUDING OSHA IN THE USA) HOLD THE OWNER/USER ULTIMATELY RESPONSIBLE TO MAINTAIN A SAFE WORKING ENVIRONMENT. ACCORDINGLY, THE OWNER/USER MUST RECOGNIZE ALL FORESEEABLE SAFETY HAZARDS, FURNISH SAFETY INSTRUCTIONS AND GUIDANCE TO ALL PERSONNEL WHO MAY COME IN CONTACT WITH THE INSTALLATION, AND PROVIDE ALL NECESSARY ADDITIONAL SAFETY GUARDS, FENCES, RESTRAINTS, DEVICES, ETC., NOT FURNISHED BY THE EQUIPMENT MANUFACTURER OR VENDOR.

**ATTENTION**  
 THE FLOOR AND/OR OTHER SUPPORT COMPONENTS MUST HAVE SUFFICIENT STRENGTH (AND RIGIDITY WITH DUE CONSIDERATION FOR NATURAL OR RESONANT FREQUENCY THEREOF) TO WITHSTAND THE FULLY LOADED WEIGHT OF THE MACHINE INCLUDING THE GOODS, THE WATER, AND ANY REPEATED SINUSOIDAL (ROTATING) FORCES GENERATED DURING ITS OPERATION. WRITE THE FACTORY FOR ADDITIONAL MACHINE DATA FOR USE BY A COMPETENT SOIL AND/OR STRUCTURAL ENGINEER.

MWF63J7, MWF63Z7 OPTIONS



BDMWF63JAB  
2020302D

**MILNOR** PELLERIN MILNOR CORPORATION  
 P.O. Box 400 Kenner, LA 70063, USA, Phone 504/467-3591,  
 FAX 504/468-3084, Email: milnorinfo@milnor.com

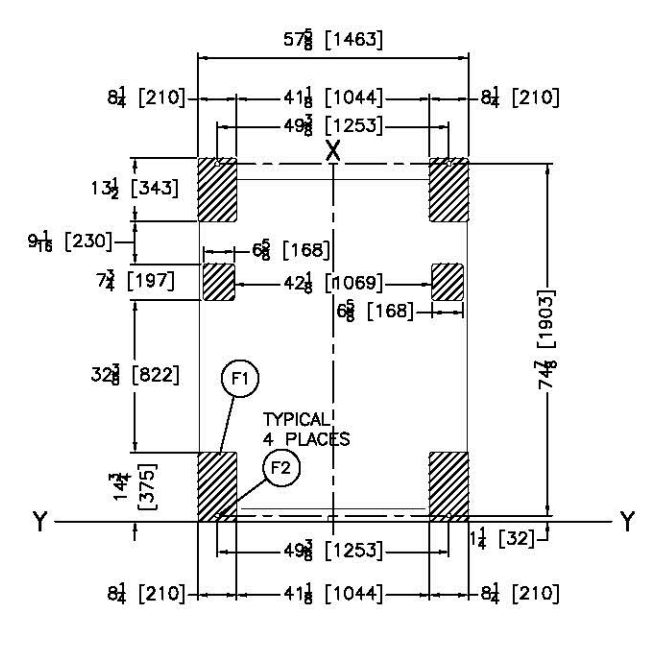
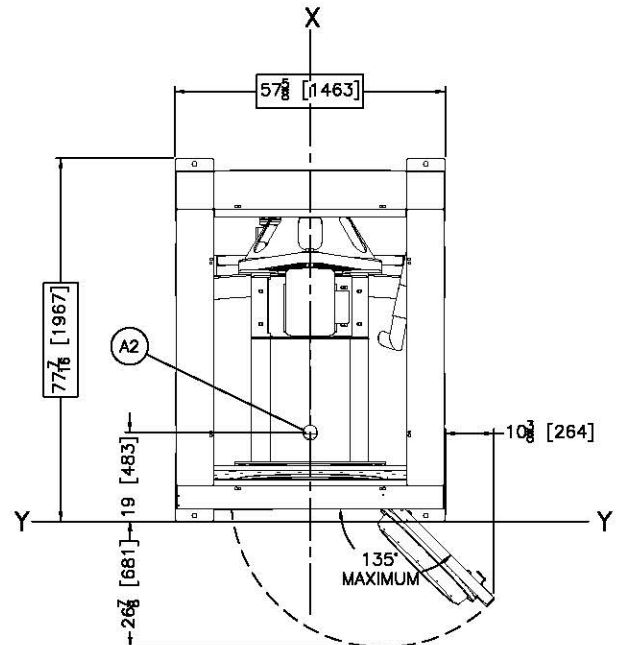
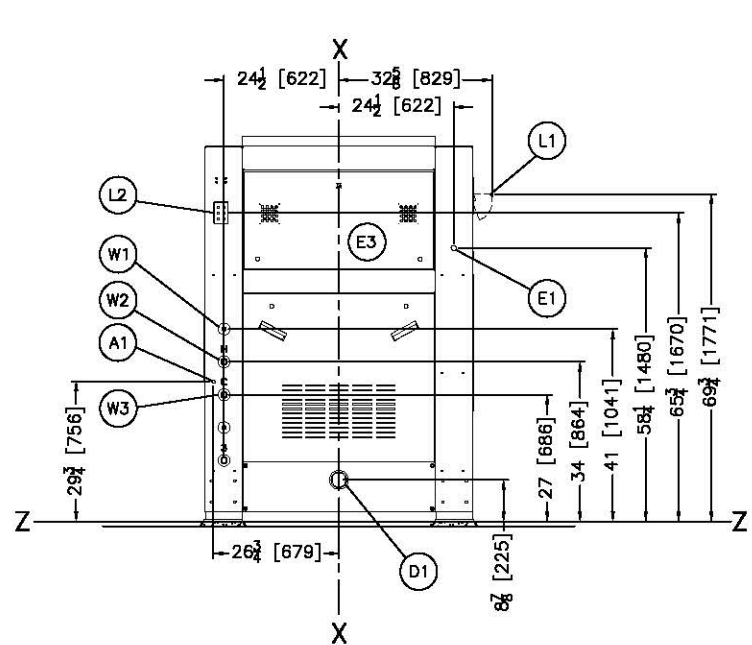
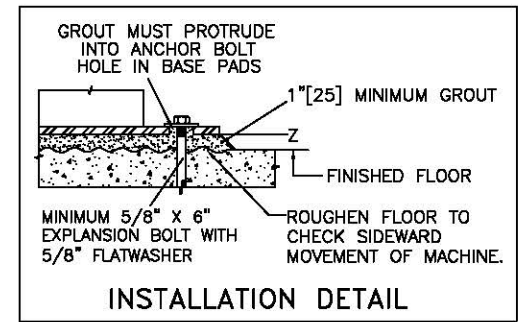

W3	COLD WATER INLET, 1-1/4" NPT CONNECTION
W2	HOT WATER FOR SUPPLY, 1-1/4" NPT CONNECTION
W1	HOT WATER FOR SUPPLY, 3/4" NPT CONNECTION, PRESSURE REGULATOR ASSEMBLY, REMOVED FOR SHIPPING, MUST BE ADDED AT INSTALLATION.
L3	ADDITIONAL LIQUID SUPPLY INLETS 15 PORT PERISTALTIC MWF77Z7 MODELS
L2	STANDARD LIQUID SUPPLY INLETS, SEE NOTE 10.
L1	STANDARD SOAP CHUTE
F4	DRAIN HOLES
F3	GROUT HOLES
F2	(4) 1-1/16" DIAMETER ANCHOR BOLT HOLES, USE 5/8" X 6" BOLTS MINIMUM.
F1	BASEPADS, 6 PLACES, SEE NOTE 8.
E3	MICROPROCESSOR CONTROL BOX
E2	E-P Plus® Controller - MWF77J7 MODELS
E1	MilTouch™ Controller - MWF77Z7 MODELS
D1	DRAIN TO REAR, AIR OPERATED, 3-1/2" OD CONNECTION
A3	CHEMICAL SUPPLY VENT
A2	VENT, 3" O.D. DIAMETER
A1	MAIN AIR, 1/4" NPT CONNECTION, CUSTOMER MUST SUPPLY AIR STRAINER

ITEM	LEGEND
------	--------

- NOTES**
- 12" [305] MINIMUM CLEARANCE IS RECOMMENDED FOR SERVICE TO MACHINE ON SIDES NOT REQUIRING OPERATOR ACCESS. 18" [457] MINIMUM IS RECOMMENDED FOR OPERATOR ACCESS TO SOAP SUPPLY. SEE LOCAL ELECTRIC CODES FOR REQUIRED CLEARANCES.
  - SHIM TO LEVEL THE MACHINE AND ALLOW FOR 1" [25] MINIMUM GROUT. ANCHOR ALL LABELED ANCHOR BOLT HOLES. USE 5/8" X 6" BOLTS, MINIMUM. SEE INSTALLATION MAINTENANCE MANUAL FOR FURTHER INSTRUCTIONS.
  - SHADED AREA DENOTES BASE PADS WHICH MUST BE CONTINUOUSLY SUPPORT.
  - DO NOT PRE-PIPE ANY CLOSER THAN 80 [1924].
  - AS OF THIS WRITING, THE MINIMUM CLEARANCE REQUIRED BY U.S. NATIONAL ELECTRIC CODES, FROM ELECTRIC BOX TO ANY OBJECT IS:
    - 36 [914] IF OBJECT IS AN UNGROUNDED (INSULATED) WALL
    - 42 [1067] IF OBJECT IS A GROUNDED WALL (i.e. BARE CONCRETE, BRICK, ETC.)
    - 48 [1219] IF OBJECT IS ANY LIVE PART.
 CHECK LOCAL ELECTRIC CODES FOR FURTHER RESTRICTIONS.
  - CUSTOMER TO SUPPLY CIRCUIT BREAKER OR FUSED BRANCH CIRCUIT DISCONNECT (SAFETY) SWITCHES WITH LAG TYPE FUSES FROM POWER SOURCE TO MACHINE. A SEPARATE GROUND WIRE MUST BE CONNECTED FROM DISCONNECT TO EQUIPMENT.
  - BASELINE "Z" IS THE SAME FOR ALL MILNOR MACHINES AND IS SHOWN ON ALL DIMENSIONAL DRAWINGS. THE DISTANCE BETWEEN BASELINE "Z" AND THE FINISHED FLOOR MAY VARY (WITH CHANGES IN FLOOR HEIGHT) AS REQUIRED TO INSURE THAT BASELINE "Z" IS HORIZONTAL AND ALL COMPONENTS REQUIRING GROUT ARE SET ON A MINIMUM 1" [25] THICK GROUT BED.
  - USE REFERENCE LINES "X", "Y", AND "Z" TO LOCATE ALL SERVICE CONNECTIONS.
  - NUMBERS IN BRACKETS [ ] DENOTE DIMENSIONS IN MILLIMETERS.
  - ALL DIMENSIONS SHOWN ARE APPROXIMATE, SUBJECT TO NORMAL MANUFACTURING TOLERANCES, AND TO OCCASIONAL CHANGES WITHOUT NOTICE THROUGH REDESIGN AND/OR RELOCATION OF COMPONENTS, ETC. DO NOT USE FOR CONSTRUCTION UNLESS CERTIFIED, AND IN NO EVENT PRE-PIPE CLOSER THAN FIVE FEET FROM MACHINE. FACTORY MUST BE CONSULTED FOR DIMENSIONS IF MACHINE IS TO BE MOVED THROUGH NARROW OR LOW CORRIDORS OR OPENINGS.

**ATTENTION**

MOST REGULATORY AUTHORITIES (INCLUDING OSHA IN THE USA) HOLD THE OWNER/USER ULTIMATELY RESPONSIBLE TO MAINTAIN A SAFE WORKING ENVIRONMENT. ACCORDINGLY, THE OWNER/USER MUST RECOGNIZE ALL FORESEEABLE SAFETY HAZARDS, FURNISH SAFETY INSTRUCTIONS AND GUIDANCE TO ALL PERSONNEL WHO MAY COME IN CONTACT WITH THE INSTALLATION, AND PROVIDE ALL NECESSARY ADDITIONAL SAFETY GUARDS, FENCES, RESTRAINTS, DEVICES, ETC., NOT FURNISHED BY THE EQUIPMENT MANUFACTURER OR VENDOR.

**ATTENTION**

THE FLOOR AND/OR OTHER SUPPORT COMPONENTS MUST HAVE SUFFICIENT STRENGTH (AND RIGIDITY WITH DUE CONSIDERATION FOR NATURAL OR RESONANT FREQUENCY THEREOF) TO WITHSTAND THE FULLY LOADED WEIGHT OF THE MACHINE INCLUDING THE GOODS, THE WATER, AND ANY REPEATED SINUSOIDAL (ROTATING) FORCES GENERATED DURING ITS OPERATION. WRITE THE FACTORY FOR ADDITIONAL MACHINE DATA FOR USE BY A COMPETENT SOIL AND/OR STRUCTURAL ENGINEER.

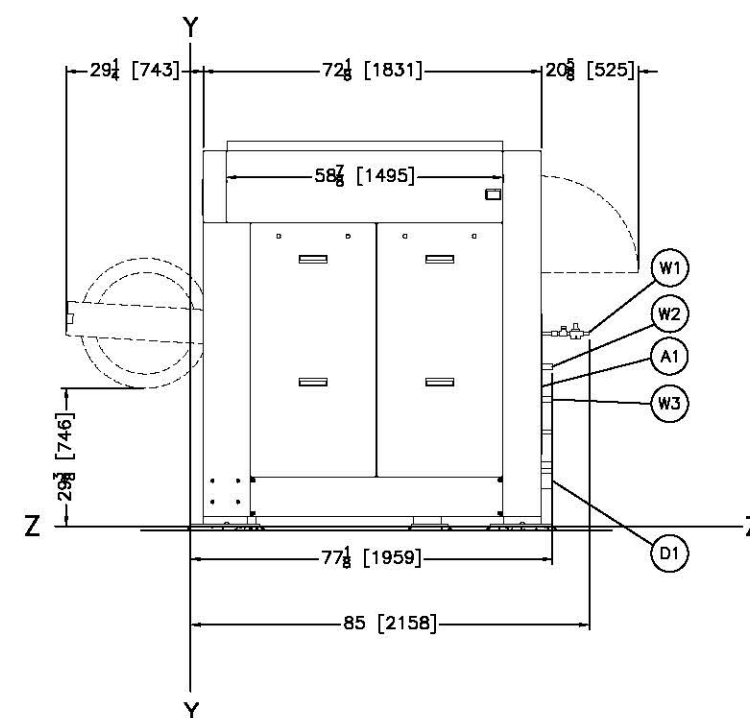
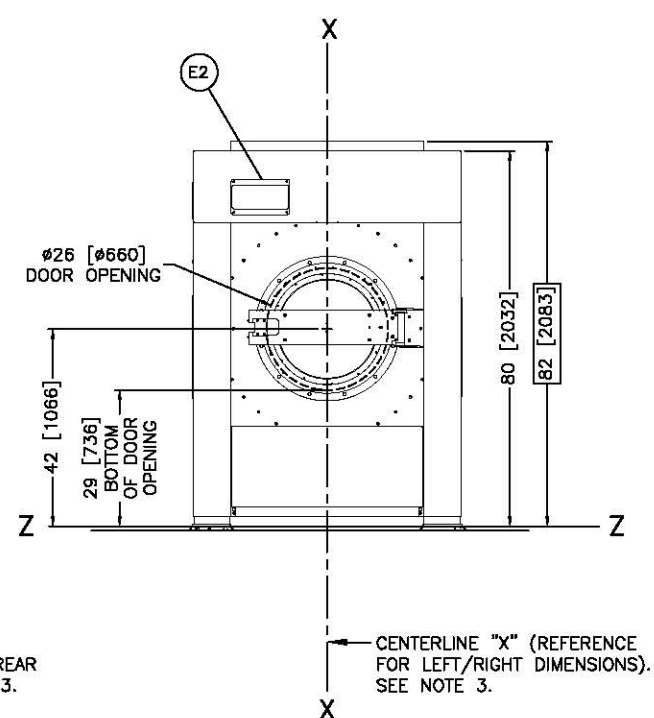
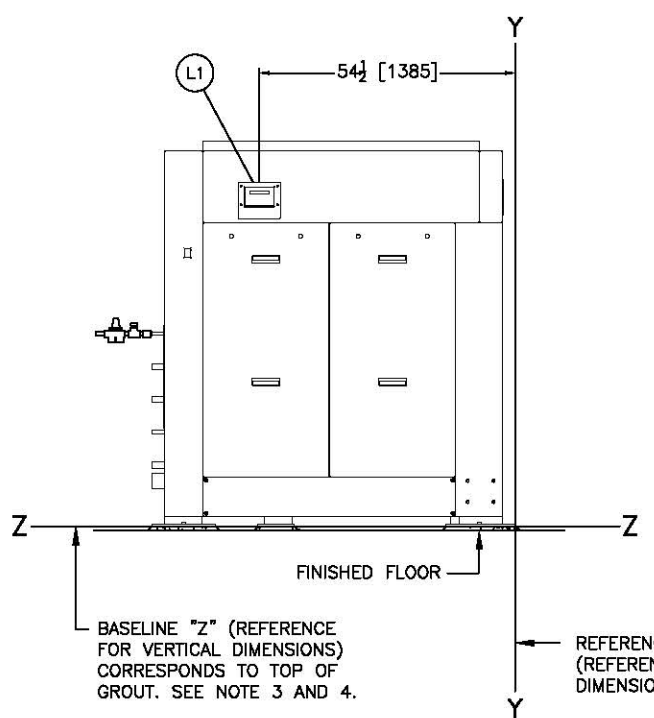

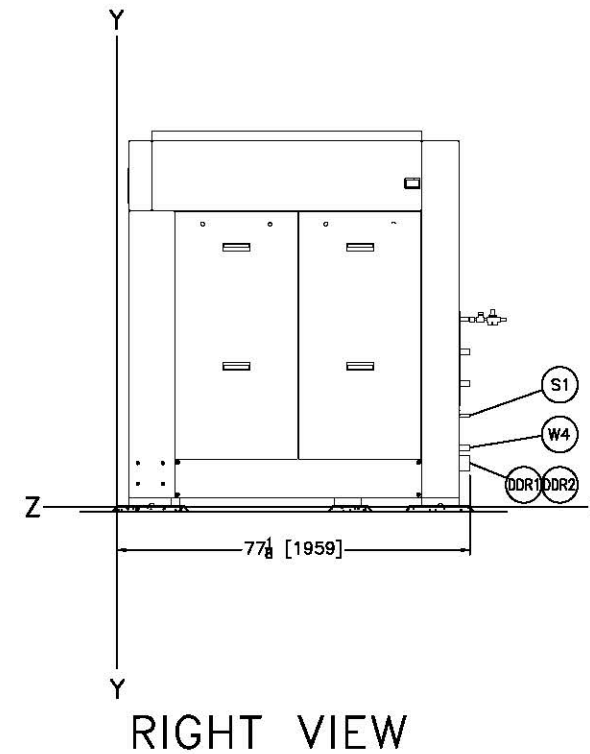
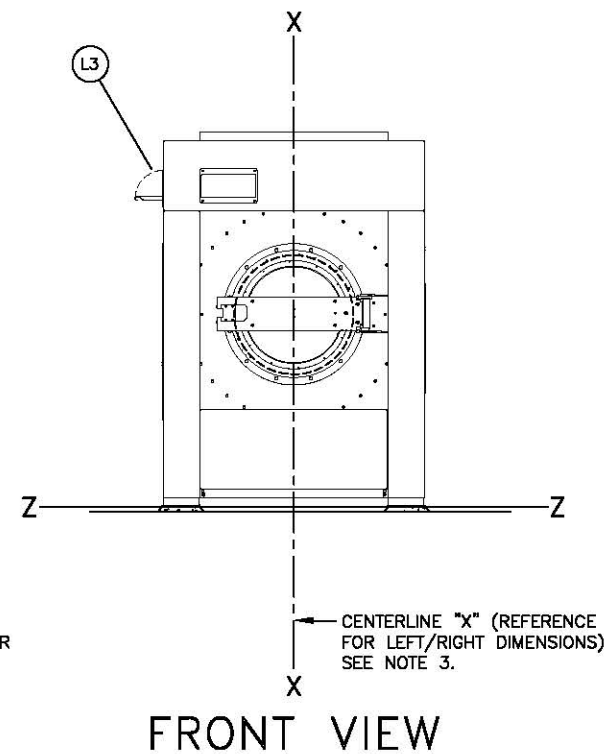
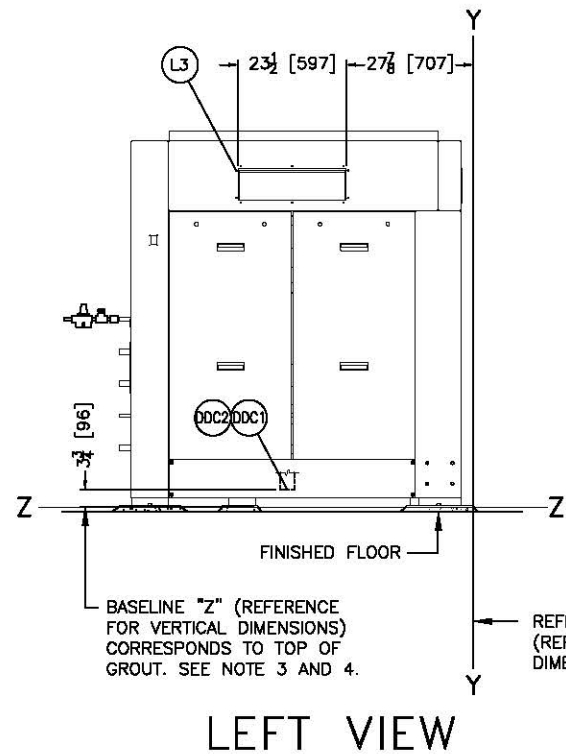
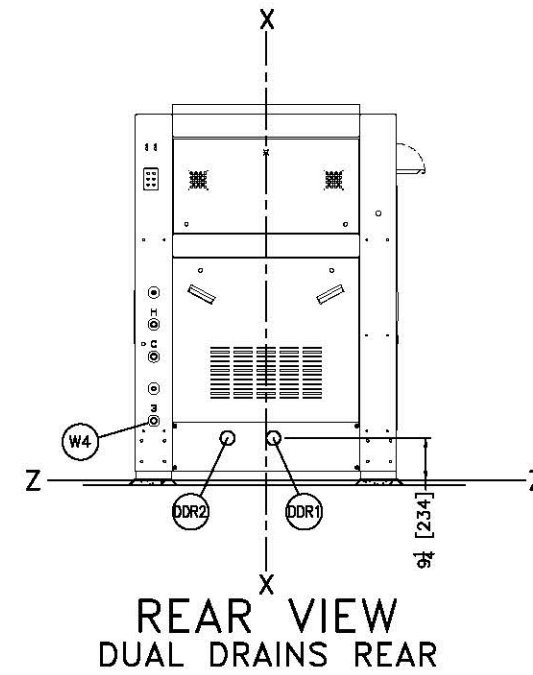
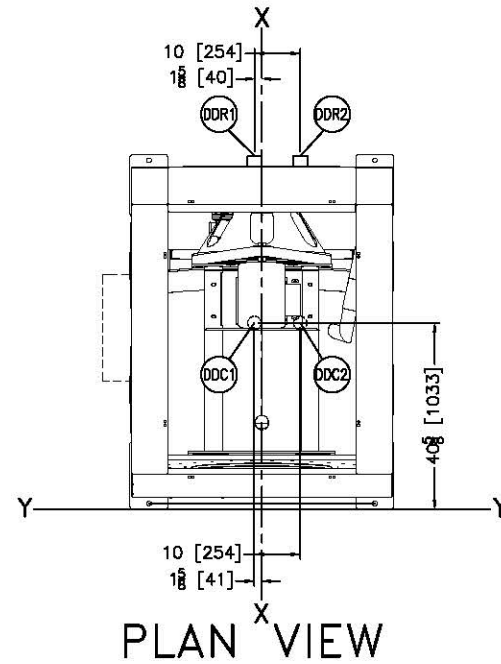
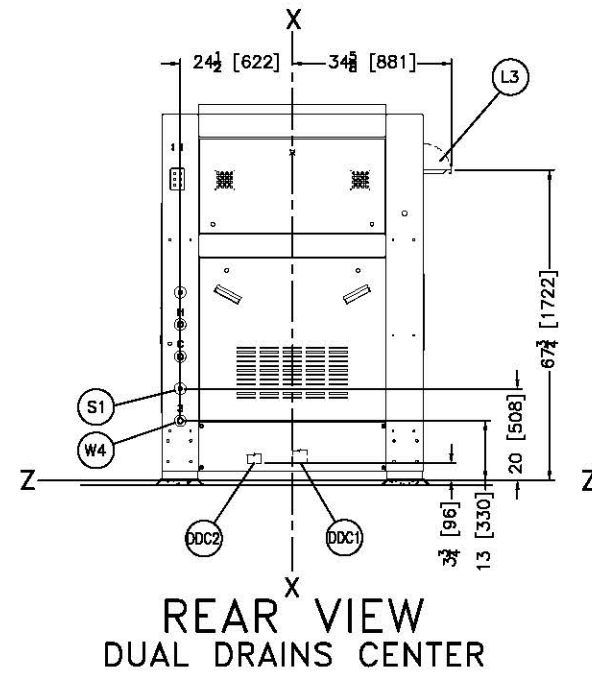

W4	AIR OPERATED REUSE WATER INLET, 1-1/4"NPT CONNECTION, PART OF DUAL DRAIN OPTION.
S1	AIR-OPERATED STEAM INLET, 1/2" NPT
L3	5 COMPARTMENT SUPPLY
DDR2	ELECTRICALLY OPERATED, DUAL DRAIN TO REAR, REUSE, 3"[76] OD. SEE W4.
DDR1	ELECTRICALLY OPERATED, DUAL DRAIN TO REAR, SEWER, 3"[76] OD.
DDC2	ELECTRICALLY OPERATED, DUAL DRAIN TO CENTER, REUSE, 3"[76] OD. SEE W4.
DDC1	ELECTRICALLY OPERATED, DUAL DRAIN TO CENTER, SEWER, 3"[76] OD.
ITEM	LEGEND

**NOTES**

6 AS OF THIS WRITING, THE MINIMUM CLEARANCE REQUIRED BY U.S. NATIONAL ELECTRIC CODES, FROM ELECTRIC BOX TO ANY OBJECT IS:  
 36 [914] IF OBJECT IS AN UNGROUNDED (INSULATED) WALL  
 42 [1067] IF OBJECT IS A GROUNDED WALL (e.g. BARE CONCRETE, BRICK, ETC.)  
 48 [1219] IF OBJECT IS ANY LIVE PART.  
 CHECK LOCAL ELECTRIC CODES FOR FURTHER RESTRICTIONS.

5 CUSTOMER TO SUPPLY CIRCUIT BREAKER OR FUSED BRANCH CIRCUIT DISCONNECT (SAFETY) SWITCHES WITH LAG TYPE FUSES FROM POWER SOURCE TO MACHINE. A SEPARATE GROUND WIRE MUST BE CONNECTED FROM DISCONNECT TO EQUIPMENT.

4 BASELINE "Z" IS THE SAME FOR ALL MILNOR MACHINES AND IS SHOWN ON ALL DIMENSIONAL DRAWINGS. THE DISTANCE BETWEEN BASELINE "Z" AND THE FINISHED FLOOR MAY VARY (WITH CHANGES IN FLOOR HEIGHT) AS REQUIRED TO INSURE THAT BASELINE "Z" IS HORIZONTAL AND ALL COMPONENTS REQUIRING GROUT ARE SET ON A MINIMUM 1" [25] THICK GROUT BED.

3 USE REFERENCE LINES "X", "Y", AND "Z" TO LOCATE ALL SERVICE CONNECTIONS.

2 NUMBERS IN BRACKETS [ ] DENOTE DIMENSIONS IN MILLIMETERS.

1 ALL DIMENSIONS SHOWN ARE APPROXIMATE, SUBJECT TO NORMAL MANUFACTURING TOLERANCES, AND TO OCCASIONAL CHANGES WITHOUT NOTICE THROUGH REDESIGN AND/OR RELOCATION OF COMPONENTS, ETC. DO NOT USE FOR CONSTRUCTION UNLESS CERTIFIED, AND IN NO EVENT PRE-PIPE CLOSER THAN FIVE FEET FROM MACHINE. FACTORY MUST BE CONSULTED FOR DIMENSIONS IF MACHINE IS TO BE MOVED THROUGH NARROW OR LOW CORRIDORS OR OPENINGS.

**ATTENTION**  
 MOST REGULATORY AUTHORITIES (INCLUDING OSHA IN THE USA) HOLD THE OWNER/USER ULTIMATELY RESPONSIBLE TO MAINTAIN A SAFE WORKING ENVIRONMENT. ACCORDINGLY, THE OWNER/USER MUST RECOGNIZE ALL FORESEEABLE SAFETY HAZARDS, FURNISH SAFETY INSTRUCTIONS AND GUIDANCE TO ALL PERSONNEL WHO MAY COME IN CONTACT WITH THE INSTALLATION, AND PROVIDE ALL NECESSARY ADDITIONAL SAFETY GUARDS, FENCES, RESTRAINTS, DEVICES, ETC., NOT FURNISHED BY THE EQUIPMENT MANUFACTURER OR VENDOR.

**ATTENTION**  
 THE FLOOR AND/OR OTHER SUPPORT COMPONENTS MUST HAVE SUFFICIENT STRENGTH (AND RIGIDITY WITH DUE CONSIDERATION FOR NATURAL OR RESONANT FREQUENCY THEREOF) TO WITHSTAND THE FULLY LOADED WEIGHT OF THE MACHINE INCLUDING THE GOODS, THE WATER, AND ANY REPEATED SINUSOIDAL (ROTATING) FORCES GENERATED DURING ITS OPERATION. WRITE THE FACTORY FOR ADDITIONAL MACHINE DATA FOR USE BY A COMPETENT SOIL AND/OR STRUCTURAL ENGINEER.

MWF77J7, MWF77Z7 OPTIONS



BDMWF77JBB  
2023072D

**MILNOR PELLERIN MILNOR CORPORATION**  
 P.O. Box 400 Kenner, LA 70063, USA, Phone 504/467-8981,  
 FAX 504/468-3084, Email: milnorinfo@milnor.com