

Published Manual Number/ECN: MPI92G4PAE/2024444A

- Publishing System: TPAS2
- Access date: 11/08/2024
- Document ECNs: NOT latest



Installation and Service

92048G4 PulseFlow®

Continuous Batch Washers

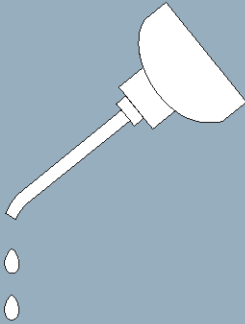

**Read the
separate
safety
manual
before
installing,
operating,
or servicing**

Table of Contents

MPI92G4PAE/24444A

Page	Description	Document
1	Limited Standard Warranty	BMP720097/2019036
2	How to Get the Necessary Repair Components	BIUUUD19/20081231
3	Trademarks	BNUUUU02/2023296A
5	1. Safety and Maintenance	
6	Safety—Continuous Batch Washer	BIUUUS27PC/20051111
11	Proximity Safeguarding for Automatic Shuttle Conveyors	BISUUI01/20171205
15	Cosmetic Covers - 92048G4 Tunnel	BMP110072/2011494A
17	Safety Placard Use and Placement 76028,76039G3 CBW & 9248G4 CBW	BMP040038/2004313V
19	Safety Placard Use and Placement ISO 76028,76039 G3 CBW & 9248 G4 CBW	BMP040039/2004313V
21	Safety Placard Use and Placement Mentor Controller for CBW	BMP040040/2004313V
23	Safety Placard Use and Placement ISO Mentor Controller for CBW	BMP040041/2004313V
25	Safety Placard Use and Placement Inverter Box for CBW	BMP040042/2004313V
27	Safety Placard Use and Placement ISO Inverter Box for CBW	BMP040043/2004313V
29	Safety Placard Use and Placement Typical All CBW Auxiliary Tanks	BMP040046/2004313V
31	Safety Placard Use and Placement ISO Typical All CBW Auxiliary Tanks	BMP040047/2004313V
33	Tag Guidelines	BIUUUI02P9/20170824
37	Prevent Damage from Chemical Supplies and Chemical Systems	BIWUUI03/2019296A
41	Torque Requirements for Fasteners	BIUUUM04/20180109
49	2. Parts and Assemblies	
51	2.1. Drive Assemblies	
52	Drive Chart - 92048G4 Tunnel	BMP110065/2011484A
55	Gear Reducer with Chain Coupling - 76028 & 76039 G3 Tunnels	BMP000033/2010052B
57	Replacing G3 Drive Chain Couplings	BIPCLM01/2000162N
61	Drive Connections - 92048G4 Tunnel	BMP110066/2011512A
64	Support Roller Assembly - 76028 & 76039G3; 92048G4 Tunnels	BMP000030/2011474B
66	Guide Roller Assembly - 76028 & 76039G3; 92048G4 Tunnels	BMP000031/2011474B
68	Tension Seal Assembly - 76028 & 76039G2 & G3; 92048G4 Tunnels	BMP840026/2011474B

Table of Contents, continued

MPI92G4PAE/24444A

Page	Description	Document
70	Shell & Cylinders - 92048G4 Tunnel	BMP110069/2011475A
72	Proximity Switch & Target Installation - 92048G4 Tunnel	BMP110070/2011492B
75	Chain Oiler	BMP110071/2013102A
77	2.2. Load Chute and Seals	
78	Load Chute and Seal Installation - 76028 & 76039G3; 92048G4 Tunnel	BMP110060/2011483B
82	Water Collectors - 76028G3, 76039G3, & 92048G4	BMP000035/2011444B
85	2.3. Water, Steam and Peristaltic	
86	PulseFlow® Water Options:Schematic and Piping	BMP170012/2023103A
99	Standard Large Split PulseFlow® Tank	BMP180011/2023103A
106	Pulse Flow Tank Fresh Water Piping 76028G3, 76039G3, 92048G4	BMP110063/2017302A
109	Steam to PulseFlow® Tank	BPTPUS01/2017302A
110	Magmeter	BMP110014/2011085B
111	Level Switch	BMP180012/2018224A
112	Level Box Lid & Latches	BMP180013/2018224A
114	Level Box & Flow Options	BMP110073/2023103A
117	Air Cylinder Fow-Not Valve 76039PF2, 92048PF	BPTP3P01/2022142A
119	Drain Stops - 76028 & 76039G3; 92048G4 Tunnel	BMP100024/2011494B
120	Drain Stop Bonnet, 4" Double Acting - 76028G3, 76039G3, & 9248G4	BMP100025/2010203B
121	Dump Valve Installation 76032, 76028, 76039, 92048 Tunnels	BMP000072/2018013A
123	Dump Valve Bonnet - 76028 & 76039G3; 92048G4 Tunnel	BMP000073/2011494B
125	Temperature Probe	BMP110077/2020355A
126	Steam Components	BMP110074/2024444A
131	Steam Components with No-Air Sparger	BMP180015/2023103A
135	Peristaltic Chemical Inlets 76028G3, 76039G3, 92048G4 Tunnels	BMP180016/2019416A
137	2.4. Pneumatics	
138	Pneumatic Shuttle Valve	BMP080032/2008462B
139	3. Installation	
140	Attention Installers! Press, Tunnel Installation	B2T2010023/2019193A
141	Shipping and Lifting Brackets - 92048G4 Tunnel	BMP110068/2011514A
143	Tunnel Feet - 92048G4 Tunnel	BMP110067/2011476A
144	Connecting Ancillary Equipment and Services	BIPCUI02/20160113
149	3.1. Dimensional Drawings	
151	Dimensional Drawing - 9248G4 PF Tunnel	BDPF92G4MXDDE/2018315D

Table of Contents, continued
MPI92G4PAE/24444A

Page	Description	Document
152	Dimensional Drawing - 9248G4 PF Tunnel Options	BDPF92G4OPDDE/2018125D
153	Dimensional Drawing - 9248G4 PF Foundation Plan	BDPF92G4FBDDE/2018125D
154	Dimensional Drawing - Drain Trough 9248G4 PF Tunnel	BDPF92G4DTDDE/2018125D
155	Dimensional Drawing - 9248G4 PF Venting	BDPF92G4VTDDE/2018125D
156	Dimensional Drawing - 9248G4 PF & MP1A56CL	BDPF92G4INDDE/2018125D
157	Dimensional Drawing - 9248G4 PF & M9T4840	BDPF92G4INDDB/2018125D

PELLERIN MILNOR CORPORATION LIMITED STANDARD WARRANTY

We warrant to the original purchaser that MILNOR machines including electronic hardware/software (hereafter referred to as "equipment"), will be free from defects in material and workmanship for a period of one year from the date of shipment (unless the time period is specifically extended for certain parts pursuant to a specific MILNOR published extended warranty) from our factory with no operating hour limitation. This warranty is contingent upon the equipment being installed, operated and serviced as specified in the operating manual supplied with the equipment, and operated under normal conditions by competent operators.

Providing we receive written notification of a warranted defect within 30 days of its discovery, we will—at our option—repair or replace the defective part or parts, EX Factory (labor and freight specifically NOT included). We retain the right to require inspection of the parts claimed defective in our factory prior to repairing or replacing same. We will not be responsible, or in any way liable, for unauthorized repairs or service to our equipment, and this warranty shall be void if the equipment is tampered with, modified, or abused, used for purposes not intended in the design and construction of the machine, or is repaired or altered in any way without MILNOR's written consent.

Parts damaged by exposure to weather, to aggressive water, or to chemical attack are not covered by this warranty. For parts which require routine replacement due to normal wear—such as gaskets, contact points, brake and clutch linings, belts, hoses, and similar parts—the warranty time period is 90 days.

We reserve the right to make changes in the design and/or construction of our equipment (including purchased components) without obligation to change any equipment previously supplied.

ANY SALE OR FURNISHING OF ANY EQUIPMENT BY MILNOR IS MADE ONLY UPON THE EXPRESS UNDERSTANDING THAT MILNOR MAKES NO EXPRESSED OR IMPLIED WARRANTIES OF MERCHANTABILITY OR FITNESS FOR ANY PARTICULAR USE OR PURPOSE OR ANY OTHER WARRANTY IMPLIED BY LAW INCLUDING BUT NOT LIMITED TO REDHIBITION. MILNOR WILL NOT BE RESPONSIBLE FOR ANY COSTS OR DAMAGES ACTUALLY INCURRED OR REQUIRED AS A RESULT OF: THE FAILURE OF ANY OTHER PERSON OR ENTITY TO PERFORM ITS RESPONSIBILITIES, FIRE OR OTHER HAZARD, ACCIDENT, IMPROPER STORAGE, MIS-USE, NEGLIGENCE, POWER OR ENVIRONMENTAL CONTROL MALFUNCTIONS, DAMAGE FROM LIQUIDS, OR ANY OTHER CAUSE BEYOND THE NORMAL RANGE OF USE. REGARDLESS OF HOW CAUSED, IN NO EVENT SHALL MILNOR BE LIABLE FOR SPECIAL, INDIRECT, PUNITIVE, LIQUIDATED, OR CONSEQUENTIAL COSTS OR DAMAGES, OR ANY COSTS OR DAMAGES WHATSOEVER WHICH EXCEED THE PRICE PAID TO MILNOR FOR THE EQUIPMENT IT SELLS OR FURNISHES.

THE PROVISIONS ON THIS PAGE REPRESENT THE ONLY WARRANTY FROM MILNOR AND NO OTHER WARRANTY OR CONDITIONS, STATUTORY OR OTHERWISE, SHALL BE IMPLIED.

WE NEITHER ASSUME, NOR AUTHORIZE ANY EMPLOYEE OR OTHER PERSON TO ASSUME FOR US, ANY OTHER RESPONSIBILITY AND/OR LIABILITY IN CONNECTION WITH THE SALE OR FURNISHING OF OUR EQUIPMENT TO ANY BUYER.

BMP720097/19036

How to Get the Necessary Repair Components



This document uses Simplified Technical English.
Learn more at <http://www.asd-ste100.org>.

You can get components to repair your machine from the approved supplier where you got this machine. Your supplier will usually have the necessary components in stock. You can also get components from the Milnor® factory.

Tell the supplier the machine model and serial number and this data for each necessary component:

- The component number from this manual
- The component name if known
- The necessary quantity
- The necessary transportation requirements
- If the component is an electrical component, give the schematic number if known.
- If the component is a motor or an electrical control, give the nameplate data from the used component.

To write to the Milnor factory:

Pellerin Milnor Corporation
Post Office Box 400
Kenner, LA 70063-0400
UNITED STATES

Telephone: 504-467-2787
Fax: 504-469-9777
Email: parts@milnor.com

— End of BIUUUD19 —

Trademarks

These words are trademarks of Pellerin Milnor® Corporation and other entities:

Table 1. Trademarks

AutoSpot™	GreenFlex™	MilMetrix®	PulseFlow®
CBW®	GearTrace™	MilTouch™	RAM Command™
Drynet™	GreenTurn™	MilTouch-EX™	RecircONE®
E-P Express®	Hydro-cushion™	MilRAIL®	RinSave®
E-P OneTouch®	Mentor®	Miltrac™	SmoothCoil™
E-P Plus®	Mildata®	MilVision™	Staph Guard®
Gear Guardian®	Milnor®	PBW™	

End of document: BNUUUU02

Safety and Maintenance

1

Safety—Continuous Batch Washer

1. General Safety Requirements—Vital Information for Management Personnel [Document BIUUUS04]

Incorrect installation, neglected preventive maintenance, abuse, and/or improper repairs, or changes to the machine can cause unsafe operation and personal injuries, such as multiple fractures, amputations, or death. The owner or his selected representative (owner/user) is responsible for understanding and ensuring the proper operation and maintenance of the machine. The owner/user must familiarize himself with the contents of all machine instruction manuals. The owner/user should direct any questions about these instructions to a Milnor® dealer or the Milnor® Service department.

Most regulatory authorities (including OSHA in the USA and CE in Europe) hold the owner/user ultimately responsible for maintaining a safe working environment. Therefore, the owner/user must do or ensure the following:

- recognize all foreseeable safety hazards within his facility and take actions to protect his personnel, equipment, and facility;
- work equipment is suitable, properly adapted, can be used without risks to health or safety, and is adequately maintained;
- where specific hazards are likely to be involved, access to the equipment is restricted to those employees given the task of using it;
- only specifically designated workers carry out repairs, modifications, maintenance, or servicing;
- information, instruction, and training is provided;
- workers and/or their representatives are consulted.

Work equipment must comply with the requirements listed below. The owner/user must verify that installation and maintenance of equipment is performed in such a way as to support these requirements:

- control devices must be visible, identifiable, and marked; be located outside dangerous zones; and not give rise to a hazard due to unintentional operation;
- control systems must be safe and breakdown/damage must not result in danger;
- work equipment is to be stabilized;
- protection against rupture or disintegration of work equipment;
- guarding, to prevent access to danger zones or to stop movements of dangerous parts before the danger zones are reached. Guards to be robust; not give rise to any additional hazards; not be easily removed or rendered inoperative; situated at a sufficient distance from the danger zone; not restrict view of operating cycle; allow fitting, replacing, or maintenance by restricting access to relevant area and without removal of guard/protection device;
- suitable lighting for working and maintenance areas;
- maintenance to be possible when work equipment is shut down. If not possible, then protection measures to be carried out outside danger zones;
- work equipment must be appropriate for preventing the risk of fire or overheating; discharges of gas, dust, liquid, vapor, other substances; explosion of the equipment or substances in it.

- 1.1. **Laundry Facility**—Provide a supporting floor that is strong and rigid enough to support—with a reasonable safety factor and without undue or objectionable deflection—the weight of the fully loaded machine and the forces transmitted by it during operation. Provide sufficient clearance for machine movement. Provide any safety guards, fences, restraints, devices, and verbal and/or posted restrictions necessary to prevent personnel, machines, or other moving machinery from accessing the machine or its path. Provide adequate ventilation to carry away heat and vapors. Ensure service connections to installed machines meet local and national safety standards, especially regarding the electrical disconnect (see the National Electric Code). Prominently post safety information, including signs showing the source of electrical disconnect.
- 1.2. **Personnel**—Inform personnel about hazard avoidance and the importance of care and common sense. Provide personnel with the safety and operating instructions that apply to them. Verify that personnel use proper safety and operating procedures. Verify that personnel understand and abide by the warnings on the machine and precautions in the instruction manuals.
- 1.3. **Safety Devices**—Ensure that no one eliminates or disables any safety device on the machine or in the facility. Do not allow machine to be used with any missing guard, cover, panel or door. Service any failing or malfunctioning device before operating the machine.
- 1.4. **Hazard Information**—Important information on hazards is provided on the machine safety placards, in the Safety Guide, and throughout the other machine manuals. **Placards must be kept clean so that the information is not obscured. They must be replaced immediately if lost or damaged. The Safety Guide and other machine manuals must be available at all times to the appropriate personnel.** See the machine service manual for safety placard part numbers. Contact the Milnor Parts department for replacement placards or manuals.
- 1.5. **Maintenance**—Ensure the machine is inspected and serviced in accordance with the norms of good practice and with the preventive maintenance schedule. Replace belts, pulleys, brake shoes/disks, clutch plates/tires, rollers, seals, alignment guides, etc. before they are severely worn. Immediately investigate any evidence of impending failure and make needed repairs (e.g., cylinder, shell, or frame cracks; drive components such as motors, gear boxes, bearings, etc., whining, grinding, smoking, or becoming abnormally hot; bending or cracking of cylinder, shell, frame, etc.; leaking seals, hoses, valves, etc.) Do not permit service or maintenance by unqualified personnel.

2. Safety Alert Messages—Internal Electrical and Mechanical Hazards [Document BIUUUS11]

The following are instructions about hazards inside the machine and in electrical enclosures.



WARNING 1: Electrocution and Electrical Burn Hazards—Contact with electric power can kill or seriously injure you. Electric power is present inside the cabinetry unless the main machine power disconnect is off.

- Do not unlock or open electric box doors.
- Do not remove guards, covers, or panels.
- Do not reach into the machine housing or frame.
- Keep yourself and others off of machine.
- Know the location of the main machine disconnect and use it in an emergency to remove all electric power from the machine.



WARNING 2: Entangle and Crush Hazards—Contact with moving components normally isolated by guards, covers, and panels, can entangle and crush your limbs. These components move automatically.

- Do not remove guards, covers, or panels.
- Do not reach into the machine housing or frame.
- Keep yourself and others off of machine.
- Know the location of all emergency stop switches, pull cords, and/or kick plates and use them in an emergency to stop machine motion. These may not stop certain devices such as pumps on some machines.



CAUTION 3: Burn Hazards—Contact with hot goods or machine components can burn you.

- Do not remove guards, covers, or panels.
- Do not reach into the machine housing or frame.

3. Safety Alert Messages—External Mechanical Hazards [Document BIUUUS12]

The following are instructions about hazards around the front, sides, rear or top of the machine.

4. Safety Alert Messages—Cylinder and Processing Hazards

[Document BIUUUS13]

The following are instructions about hazards related to the cylinder and laundering process.



WARNING 4: Confined Space Hazards—Confinement in the cylinder can kill or injure you. Hazards include but are not limited to panic, burns, poisoning, suffocation, heat prostration, biological contamination, electrocution, and crushing.

- Do not attempt unauthorized servicing, repairs, or modification.



WARNING 5: Explosion and Fire Hazards—Flammable substances can explode or ignite in the cylinder, drain trough, or sewer. The machine is designed for washing with water, not any other solvent. Processing can cause solvent-containing goods to give off flammable vapors.

- Do not use flammable solvents in processing.
- Do not process goods containing flammable substances. Consult with your local fire department/public safety office and all insurance providers.

5. Safety Alert Messages—Unsafe Conditions [Document BIUUUS14]

5.1. Damage and Malfunction Hazards

5.1.1. Hazards Resulting from Inoperative Safety Devices



WARNING 6: Multiple Hazards—Operating the machine with an inoperative safety device can kill or injure personnel, damage or destroy the machine, damage property, and/or void the warranty.

- Do not tamper with or disable any safety device or operate the machine with a malfunctioning safety device. Request authorized service.



WARNING 7: Electrocutation and Electrical Burn Hazards—Electric box doors—Operating the machine with any electric box door unlocked can expose high voltage conductors inside the box.

- Do not unlock or open electric box doors.



WARNING 8: Entangle and Crush Hazards—Guards, covers, and panels—Operating the machine with any guard, cover, or panel removed exposes moving components.

- Do not remove guards, covers, or panels.

5.1.2. Hazards Resulting from Damaged Mechanical Devices



WARNING 9: Multiple Hazards—Operating a damaged machine can kill or injure personnel, further damage or destroy the machine, damage property, and/or void the warranty.

- Do not operate a damaged or malfunctioning machine. Request authorized service.



CAUTION 10: Machine Damage Hazards—Drive shaft and drive motors—Although the tunnel may operate with drive shafts disconnected between modules or units, or with a motor not functioning, the added stress on drive components will quickly damage the machine.

- Do not operate the machine with any evidence of damage or malfunction.

5.2. Careless Use Hazards

5.2.1. Careless Operation Hazards—Vital Information for Operator Personnel (see also operator hazards throughout manual)



WARNING 11: Multiple Hazards—Careless operator actions can kill or injure personnel, damage or destroy the machine, damage property, and/or void the warranty.

- Do not tamper with or disable any safety device or operate the machine with a malfunctioning safety device. Request authorized service.
- Do not operate a damaged or malfunctioning machine. Request authorized service.
- Do not attempt unauthorized servicing, repairs, or modification.
- Do not use the machine in any manner contrary to the factory instructions.
- Use the machine only for its customary and intended purpose.
- Understand the consequences of operating manually.



CAUTION 12: Goods Damage and Wasted Resources—Entering incorrect cake data causes improper processing, routing, and accounting of batches.

- Understand the consequences of entering cake data.

5.2.2. Careless Servicing Hazards—Vital Information for Service Personnel (see also service hazards throughout manuals)



WARNING 13: Electrocutation and Electrical Burn Hazards—Contact with electric power can kill or seriously injure you. Electric power is present inside the cabinetry unless the main machine power disconnect is off.

- Do not service the machine unless qualified and authorized. You must clearly understand the hazards and how to avoid them.
- Abide by the current OSHA lockout/tagout standard when lockout/tagout is called for in the service instructions. Outside the USA, abide by the OSHA standard in the absence of

any other overriding standard.



WARNING 14: Entangle and Crush Hazards—Contact with moving components normally isolated by guards, covers, and panels, can entangle and crush your limbs. These components move automatically.

- Do not service the machine unless qualified and authorized. You must clearly understand the hazards and how to avoid them.
- Abide by the current OSHA lockout/tagout standard when lockout/tagout is called for in the service instructions. Outside the USA, abide by the OSHA standard in the absence of any other overriding standard.



WARNING 15: Confined Space Hazards—Confinement in the cylinder can kill or injure you. Hazards include but are not limited to panic, burns, poisoning, suffocation, heat prostration, biological contamination, electrocution, and crushing.

- Do not enter the cylinder until it has been thoroughly purged, flushed, drained, cooled, and immobilized.
- Abide by the confined space entry procedures in the reference manual.

— End of BIUUUS27 —

Proximity Safeguarding for Automatic Shuttle Conveyors

Proximity safeguarding—a means of preventing personnel from entering the path of a machine, such as an industrial robot, that moves within a large area.

1. Applicability

This document—

applies to Milnor® automated laundering systems with shuttle conveyors that move without operator intervention (automatic operation),

does not apply to shuttles that require operator input continually, such as directing all shuttle movements (manual operation).

2. References for Proximity Safeguarding

ANSI Z8.1-2016 “American National Standard for Commercial Laundry and Drycleaning Equipment and Operations - Safety Requirements”

OSHA Standard 29 CFR § 1910.212 “General Requirements for All Machines”

OSHA Directive STD 01-12-002 - Pub 8-1.3 “Guidelines for Robotic Safety”

ANSI/RIA R15.06-2012 “American National Standard for Industrial Robots and Robot Systems- Safety Requirements”

ANSI/ASME B15.1-2000 “Safety Standard for Mechanical Power Transmission Apparatus”

OSHA Publication 3067 “Concepts and Techniques of Machine Safeguarding”

ISO 10472-1 “Safety Requirements for Industrial Laundry Machinery”

3. Hazards To Personnel in Proximity to Shuttle Conveyors

Milnor automated laundering systems use automatic shuttle conveyors to transport goods among the processing machines in the system. Depending on model, an automatic shuttle conveyor may move in any of the following ways, in addition to running its conveyor belt(s):

- It may travel along (traverse) a line of machines (typically dryers).
- Its conveyor bed(s) may ascend and descend (elevate) within the machine frame.
- Its conveyor bed(s) may extend and retract within the machine frame.
- The conveyor bed and frame may pivot.
- Wet goods shuttles have a bucket that elevates and tilts.

These motions pose strike, crush, sever, and entrapment hazards to personnel in proximity to the shuttle. **For the safety of personnel, owner/users must provide proximity safeguarding that protects personnel from the moving shuttle.**

A common method of proximity safeguarding is safety fencing with interlocked gates that disable the shuttle when a gate is opened. When a shuttle is disabled, this will eventually cause other machines in the system to hold (wait for action from another machine), but it will not necessarily cause them to immediately stop moving. In the case of a tunnel system, the press or centrifugal extractor can pose additional hazards to personnel in proximity to the equipment. **Hence, the safeguards must also disable any presses or extractors.** Tunnels and dryers do not pose a significant hazard to personnel merely because they are in proximity to the equipment, and need not be automatically disabled.



WARNING 1: Multiple Hazards—Proximity safeguarding provides only partial protection and only against injury resulting from entering the shuttle path. It is not a substitute for proper

lockout/tagout procedures and good safety practices.

- Always lockout/tagout any individual machine (or follow the published maintenance procedures) when performing maintenance or clearing a fault on that machine.
- Ensure that all personnel understand the safeguards and do not attempt to defeat them.
- Inspect safeguards weekly to ensure that they are not mechanically or electrically circumvented.

4. How Milnor Accommodates Proximity Safeguarding

Milnor provides connection points on shuttles, presses and centrifugal extractors for interfacing with devices such as gate interlock switches. These connection points are tagged for easy identification. When Milnor provides equipment layout drawings for an automated laundering system, it indicates on the drawing, the perimeter of the shuttle movement area that must be guarded. The following hazard statement is displayed on connection point tags as well as equipment layout drawings prepared by Milnor:



WARNING 2: Strike, Crush, Sever, and Entrapment Hazards—Serious bodily injury or death can result to personnel in proximity to machinery/systems that traverse, elevate, extend, pivot, and/or tilt. The following mandatory minimum safety requirements must be installed with the machinery system (local codes may require additional precautions):

- Safety fence enclosing machine movement areas,
- Lockable electrical interlocks on all gates, properly interfaced as shown on machine schematics, to disable machine movement when any gate is opened,
- Signs to alert personnel to these hazards, placed prominently around the fenced area.

Although the objectives of proximity safeguarding are the same anywhere, design requirements vary with local codes (which occasionally change) and with the plant layout. For this reason, Milnor does not provide detailed designs or materials for proximity safeguarding. If the necessary expertise does not exist within the owner/user's organization, consult appropriate sources such as local engineers or architects specializing in industrial facility design.

5. Examples of Safety Fencing With Interlocked Gates

Fencing with interlocked gates like that depicted in [Figure 1](#) and [Figure 2](#), may be used to meet the proximity safeguarding requirement. Should the owner/user choose this method, the following information may be useful. However, **this information may not satisfy current or local code requirements. The owner/user must determine its suitability for his particular facility.**

Figure 1: Example Fence Layout for Automated Laundering System Where One Tunnel Serves a Bank of Dryers

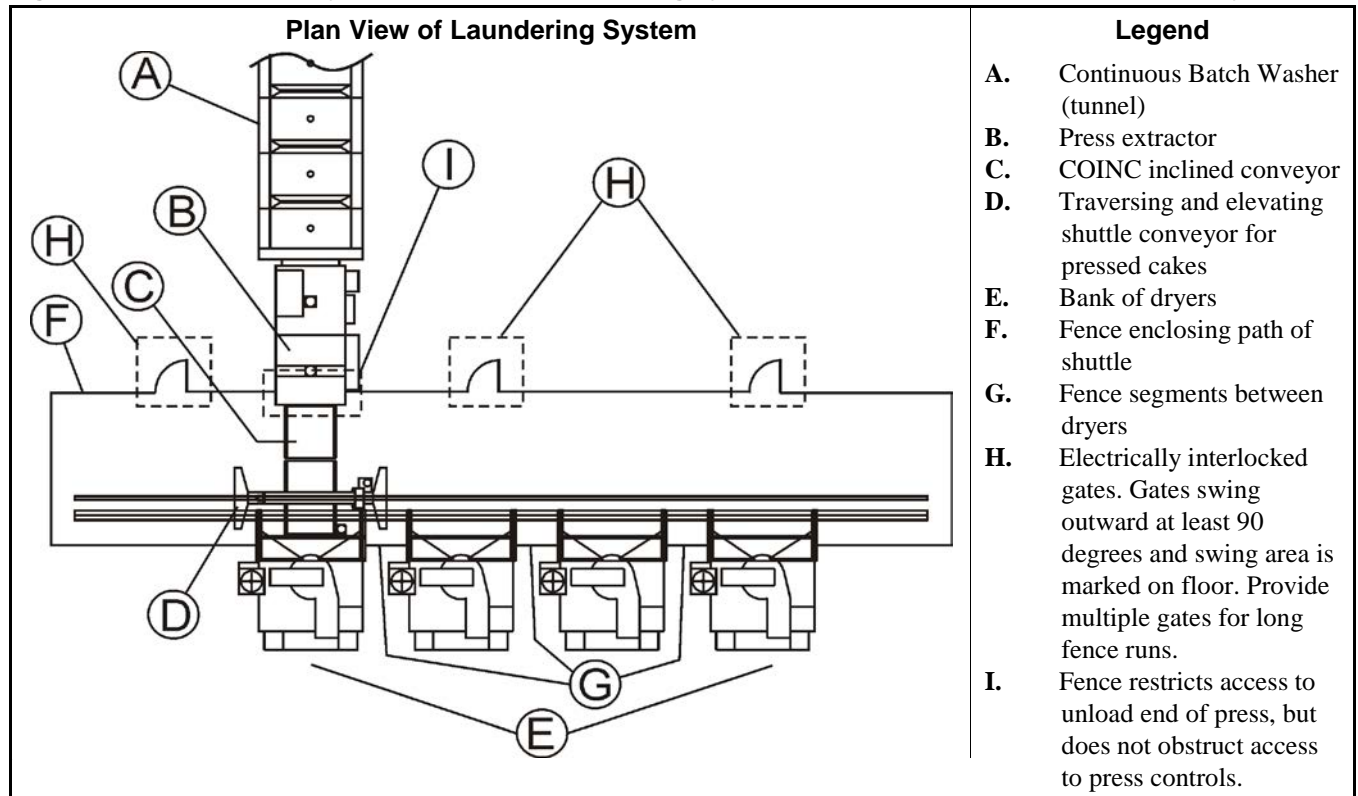
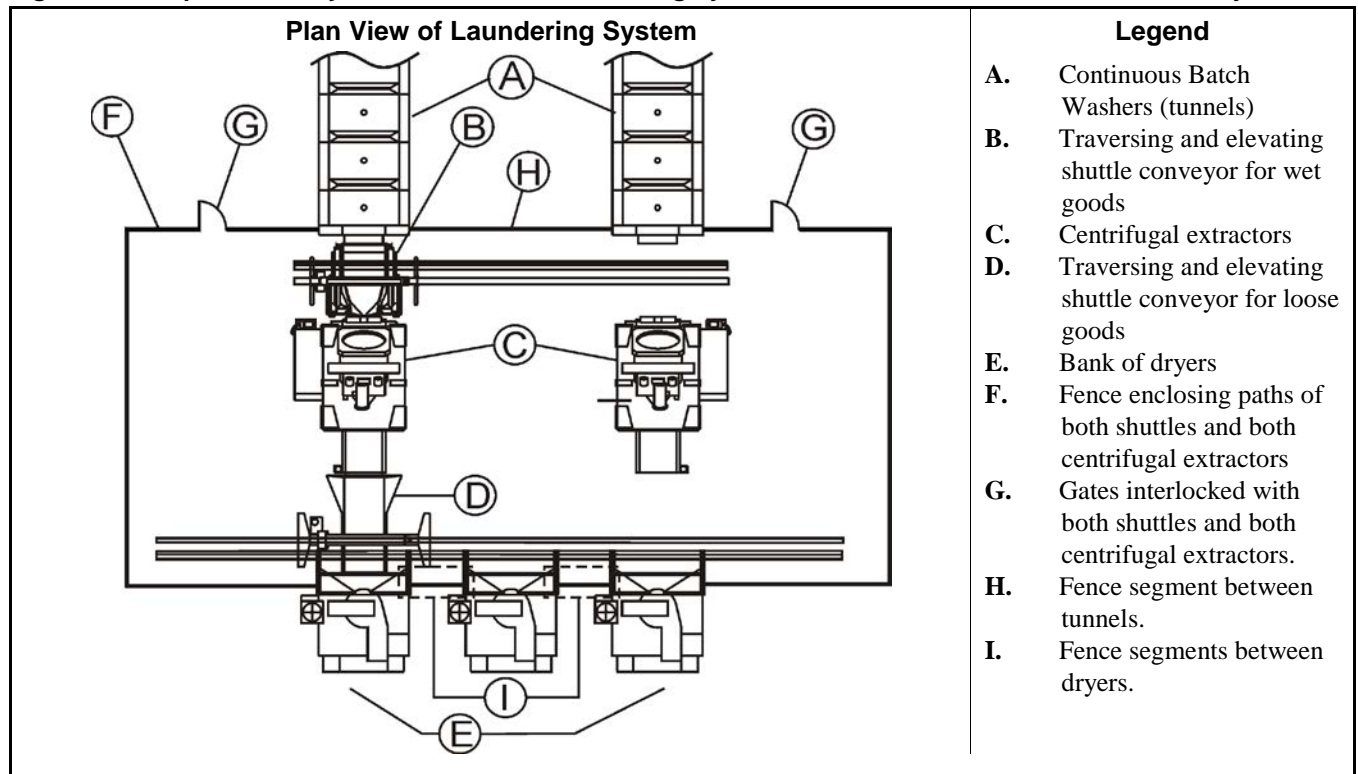

Figure 2: Example Fence Layout for Automated Laundering System Where Two Tunnels Serve a Bank of Dryers



- 5.1. Fence Dimensions**—The fence must discourage climbing over and prevent crawling under.
- 5.2. Fence Materials and Setback**—The fence must be constructed of materials and located so as to prevent personnel from reaching through gaps in the fence and contacting the enclosed machinery.
- 5.3. Gates**—Personnel gates must be held firmly closed but permit personnel to easily pass through when necessary. Gates must be equipped with a positive latching arrangement to prevent accidental opening. Adequate floor space must be provided to allow the gate to swing at least 90 degrees when fully open. Gates must open outward; that is, away from the fenced perimeter. The floor must be permanently marked to show the gate’s swing area, to discourage obstructing its movement.
- 5.4. Control Circuitry**—All gates must be electrically interlocked with any shuttle conveyors within the fenced area and with any presses or centrifugal extractors that the fence either encloses or intersects. Opening any gate must have the following effects:
1. Shuttle(s), press(es), and/or centrifugal extractor(s) stop moving immediately.
 2. An audible alarm sounds.
 3. Shuttle(s), press(es), and/or centrifugal extractor(s) cannot be restarted merely by closing the gate(s), but must be restarted at the machine control panel once the gate(s) are closed.
- Milnor shuttles, presses and centrifugal extractors provide such functionality when properly interfaced with gate interlock switches.
- 5.5. System Emergency Stop Switches**—The laundry must establish rules and procedures that prohibit personnel from remaining within the fenced area with machine(s) enabled, except in accordance with published maintenance procedures. System emergency stop switches (panic buttons) should be provided inside and outside the fenced perimeter. Emergency stop switches should be located so that personnel anywhere inside the fenced perimeter are only a short distance from a switch, and they should be clearly marked as to their locations and function. Connect switches in series with the gate interlocks so that pressing an emergency stop switch performs the same control function as opening a gate.
- 5.6. Isolating Individual Machine Controls**—The interlock circuitry for each machine must be electrically isolated from that of the other machines. Hence, each gate interlock switch must provide as many pairs of dry contacts as there are machines to interface to. A pair of switch contacts must never be shared by two or more machines.
- 5.7. Recommended Signage**—Safety placards should be posted along the fence and at each gate, alerting personnel to the hazards within. At minimum, the size of lettering and distance between placards should be such that anyone contemplating entering the fenced area will likely see and read the placard first. Wording should be provided in each native language spoken by laundry personnel.

— End of BISUII01 —

Cosmetic Covers

92048G4 Tunnels

BMP110072/2011494A
(1 / 2)



Pellerin Milnor Corporation
P. O. Box 400, Kenner, LA 70063-0400

Litho in U.S.A.

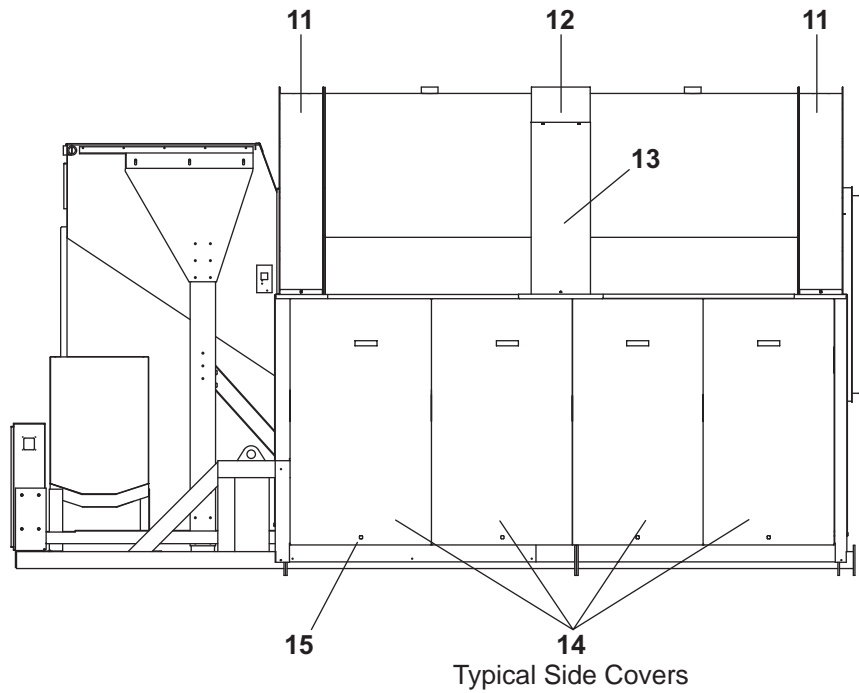
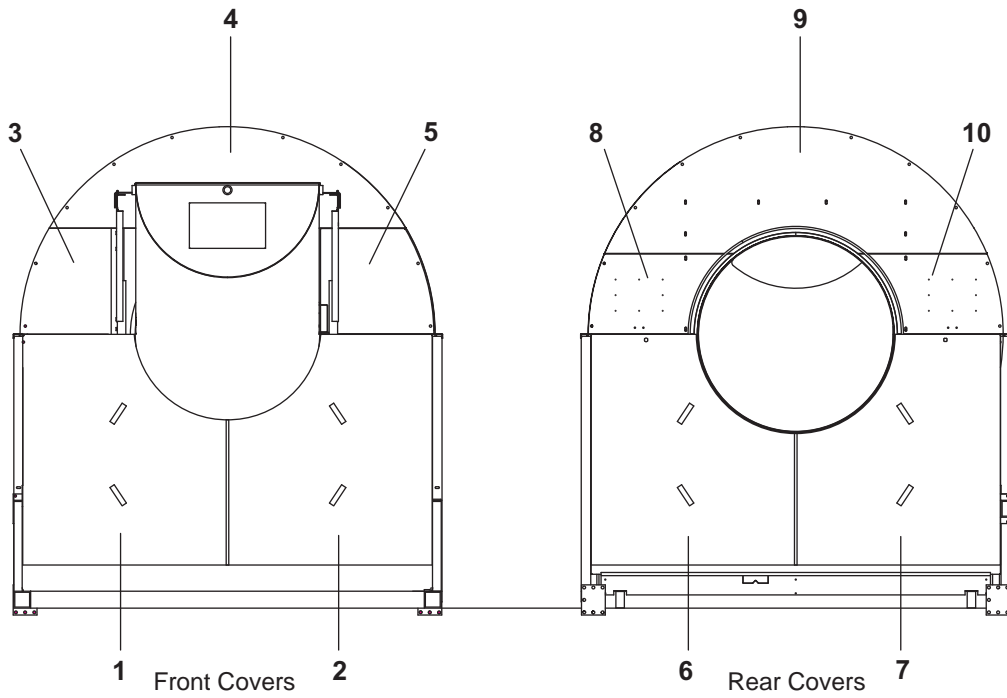



Pellerin Milnor Corporation
P. O. Box 400, Kenner, LA 70063-0400

Litho in U.S.A.

Parts List—Cosmetic Covers

Find the correct assembly first, then find the needed components. The item letters (A, B, C, etc.) assigned to assemblies are referred to in the "Used In" column to identify which components belong to an assembly. The item numbers (1, 2, 3, etc.) assigned to components relate the parts list to the illustration.

Used In	Item	Part Number	Description	Comments
-----ASSEMBLIES-----				
	A	GGC63001	9248 FIRST MOD COSMETIC INSTAL	
	B	GGC63002	9248 3MID MOD COSMETIC INSTAL	
	C	GGC63003	3MOD/LAST COSMETIC INSTALL	
	D	GGC63004	SINGLE LAST MOD COSMETIC INST	
-----COMPONENTS-----				
all	1	AGC63001A	9248 1ST MOD END COVER LF ASSY	
all	2	AGC63001	9248 1ST MOD END COVER RT ASSY	
all	3	06 30162A	9248 END COSMETIC UPPER LF	
all	4	06 30161	9248 END COSMETIC UPPER	
all	5	06 30162	9248 END COSMETIC UPPER RT	
all	6	AGC63004	9248 LAST MOD END COVER RT ASY	
all	7	AGC63004A	9248 LAST MOD END COVER LF ASY	
all	8	06 30147	9248 END COSM EXIT UPPER LF	
all	9	06 30146	9248 END COSMETIC EXIT UPPER	
all	10	06 30147A	9248 END COSM EXIT UPPER LF	
all	11	06 30160	9248 END COSMETIC WRAPPER	
all	12	06 30157	MID MOD CONNECT WRAP TOP	
all	13	06 30155	MID MOD LOWER CONNECT WRAP	
all	14	AGC63002	9248 COSMETIC SIDE COVER ASSY	
all	15	27A102M	WISE-ACT.DBBIT.LATCH#E3-12-27	

Safety Placard Use and Placement

76028,76039 G3 CBW & 92048 G4 CBW

BMP040038/2004313V
(Sheet 1 of 2)



Pellerin Milnor Corporation
P. O. Box 400, Kenner, LA 70063-0400

Litho in U.S.A.

Notes:

1. Replace placard immediately, if removed or unreadable.
2. Approximate locations of placards are shown. Mounting holes are provided on machine. If aluminum placard use #8 self-tapping screws.

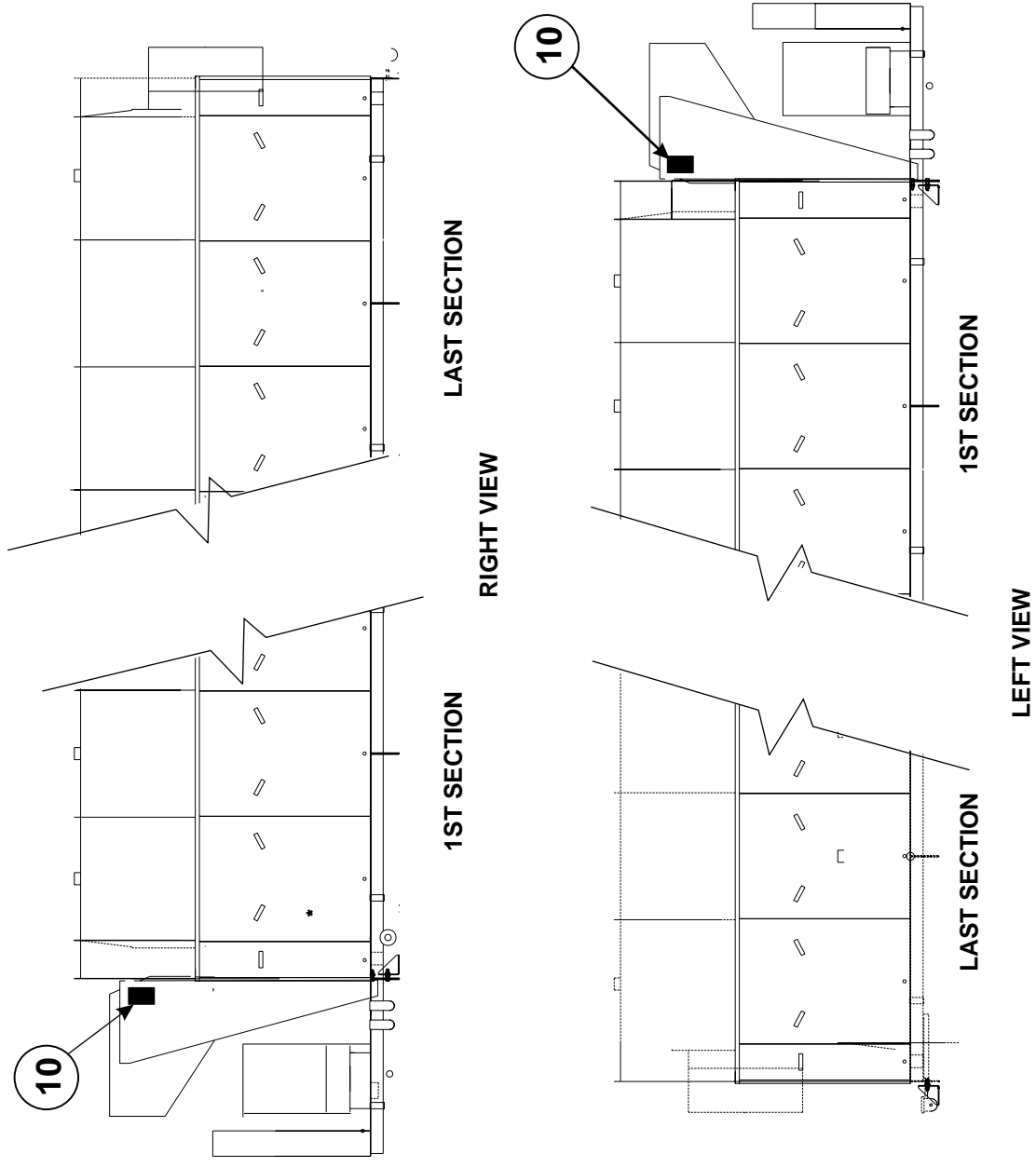



Pellerin Milnor Corporation
P. O. Box 400, Kenner, LA 70063-0400

Litho in U.S.A.

Parts List—Safety Placard Placement

Find the correct assembly first, then find the needed components. The item letters (A, B, C, etc.) assigned to assemblies are referred to in the "Used In" column to identify which components belong to an assembly. The item numbers (1, 2, 3, etc.) assigned to components relate the parts list to the illustration.

Used In	Item	Part Number	Description	Comments
-----ASSEMBLIES-----				
none				
-----COMPONENTS-----				
all	10	01 10511A	NPLT:CBW END HAZARD-TCATA	
all	20	01 10377A	NPLT:ELEC HAZARD LG-TCATA	
all	30	01 10699B	NPLT:SERV HZRD-ALUM-TCATA	

**Safety Placard Use and Placement ISO
76028,76039 G3 CBW & 92048 G4 CBW**

BMP040039/2004313V
(Sheet 1 of 2)



Pellerin Milnor Corporation
P. O. Box 400, Kenner, LA 70063-0400

Litho in U.S.A.

**ISO Placards
shown on this page**

Notes:

1. Replace placard immediately, if removed or unreadable.
2. Approximate locations of placards are shown. Mounting holes are provided on machine. If aluminum placard use #8 self-tapping screws.

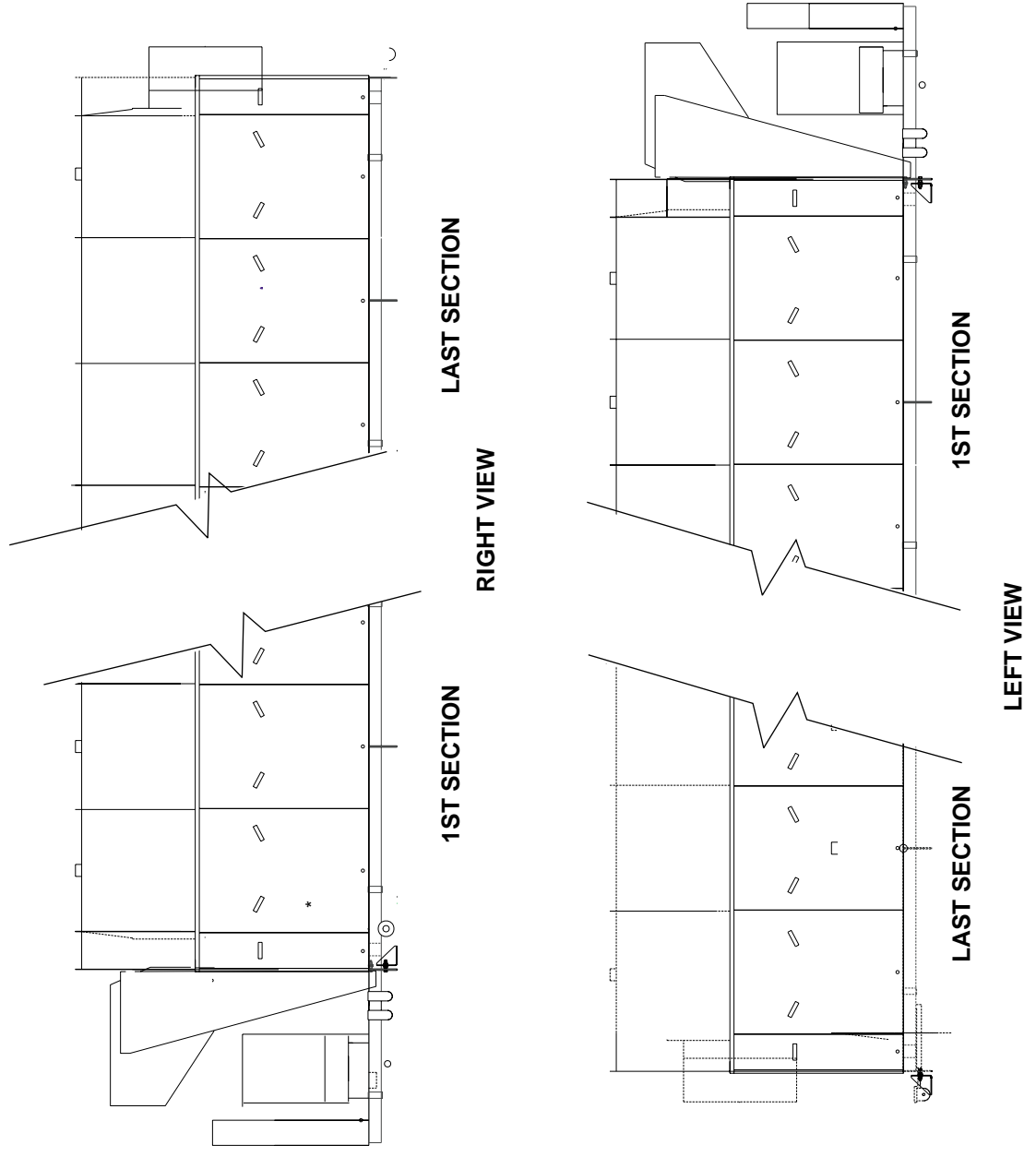



Pellerin Milnor Corporation
 P. O. Box 400, Kenner, LA 70063-0400

Litho in U.S.A.

Parts List—Safety Placard Placement

Find the correct assembly first, then find the needed components. The item letters (A, B, C, etc.) assigned to assemblies are referred to in the "Used In" column to identify which components belong to an assembly. The item numbers (1, 2, 3, etc.) assigned to components relate the parts list to the illustration.

Used In	Item	Part Number	Description	Comments
-----ASSEMBLIES-----				
			none	
-----COMPONENTS-----				
all	10	01 10511X	NPLT:CBW WARNINGS	
all	20	01 10377	NPLTE:"WARNING" 4X4	

Safety Placard Use and Placement

Mentor Controller for CBW

BMP040040/2004313V
(Sheet 1 of 2)



Pellerin Milnor Corporation
P. O. Box 400, Kenner, LA 70063-0400

Litho in U.S.A.

Notes:

1. Replace placard immediately, if removed or unreadable.
2. Approximate locations of placards are shown. Mounting holes are provided on machine. If aluminum placard use #8 self-tapping screws.

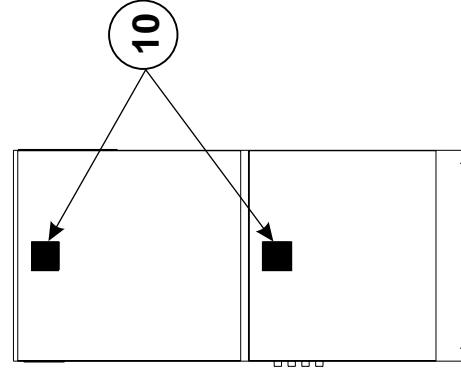

REAR VIEW

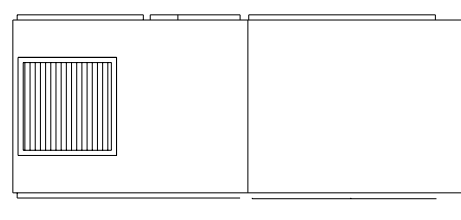

LEFT VIEW

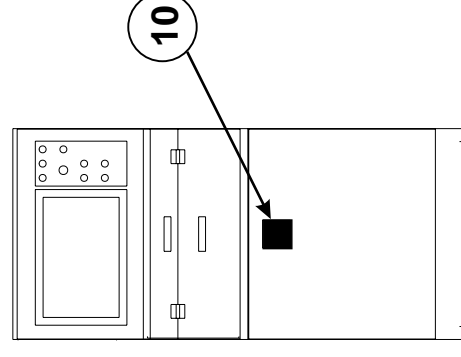

FRONT VIEW

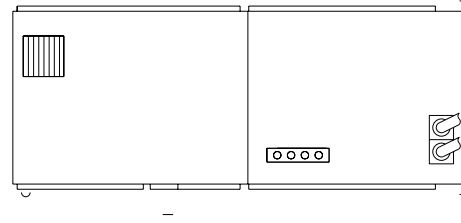

RIGHT VIEW



Pellerin Milnor Corporation
P. O. Box 400, Kenner, LA 70063-0400

Litho in U.S.A.

Parts List—Safety Placard Placement

Find the correct assembly first, then find the needed components. The item letters (A, B, C, etc.) assigned to assemblies are referred to in the "Used In" column to identify which components belong to an assembly. The item numbers (1, 2, 3, etc.) assigned to components relate the parts list to the illustration.

Used In	Item	Part Number	Description	Comments
-----ASSEMBLIES-----				
none				
-----COMPONENTS-----				
all	10	01 10377A	NPLT:ELEC HAZARD LG-TCATA	



ISO Placards shown on this page

Notes:

1. Replace placard immediately, if removed or unreadable.
2. Approximate locations of placards are shown. Mounting holes are provided on machine. If aluminum placard use #8 self-tapping screws.

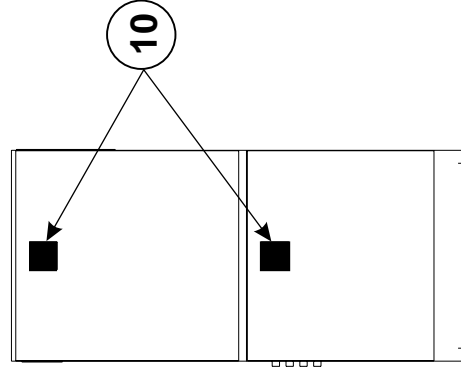

REAR VIEW

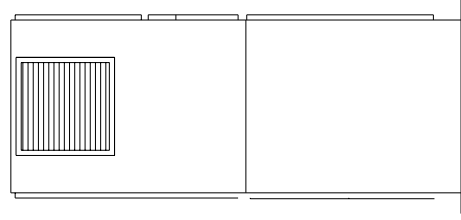

LEFT VIEW

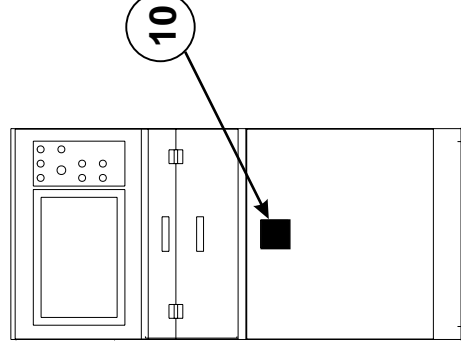

FRONT VIEW

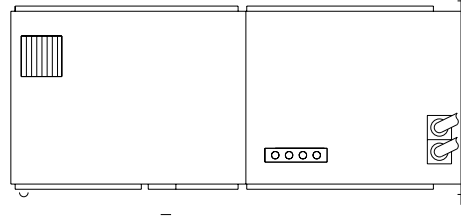

RIGHT VIEW



Pellerin Milnor Corporation
 P. O. Box 400, Kenner, LA 70063-0400

Litho in U.S.A.

Parts List—Safety Placard Placement

Find the correct assembly first, then find the needed components. The item letters (A, B, C, etc.) assigned to assemblies are referred to in the "Used In" column to identify which components belong to an assembly. The item numbers (1, 2, 3, etc.) assigned to components relate the parts list to the illustration.

Used In	Item	Part Number	Description	Comments
-----ASSEMBLIES-----				
none				
-----COMPONENTS-----				
all	10	01 10377	NPLTE:"WARNING" 4X4	

Safety Placard Use and Placement

Inverter Box for CBW

BMP040042/2004313V
(Sheet 1 of 2)



Pellerin Milnor Corporation
P. O. Box 400, Kenner, LA 70063-0400

Litho in U.S.A.

Notes:

1. Replace placard immediately, if removed or unreadable.
2. Approximate locations of placards are shown. Mounting holes are provided on machine. If aluminum placard use #8 self-tapping screws.

10

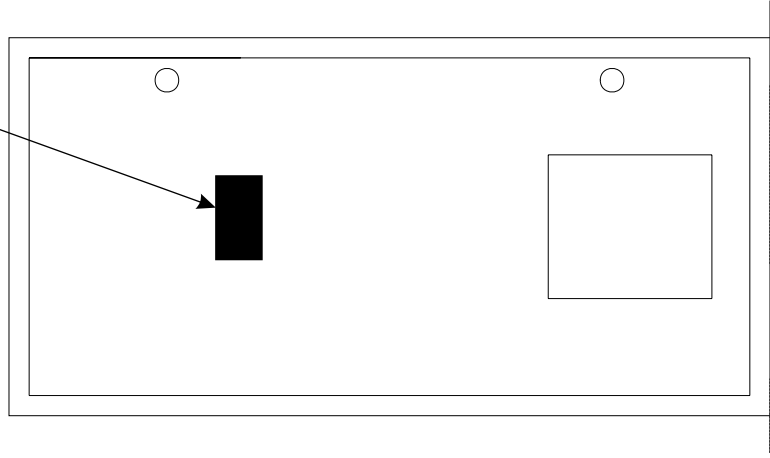

FRONT VIEW

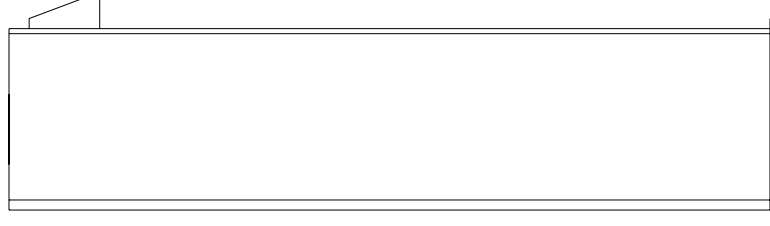

RIGHT VIEW



Pellerin Milnor Corporation
P. O. Box 400, Kenner, LA 70063-0400

Litho in U.S.A.

Parts List—Safety Placard Placement

Find the correct assembly first, then find the needed components. The item letters (A, B, C, etc.) assigned to assemblies are referred to in the "Used In" column to identify which components belong to an assembly. The item numbers (1, 2, 3, etc.) assigned to components relate the parts list to the illustration.

Used In	Item	Part Number	Description	Comments
-----ASSEMBLIES-----				
none				
-----COMPONENTS-----				
all	10	01 10377A	NPLT:ELEC HAZARD LG-TCATA	

Safety Placard Use and Placement - ISO Inverter Box for CBW

BMP040043/2004313V
(Sheet 1 of 2)



Pellerin Milnor Corporation
P. O. Box 400, Kenner, LA 70063-0400

Litho in U.S.A.

ISO Placards shown on this page

Notes:

1. Replace placard immediately, if removed or unreadable.
2. Approximate locations of placards are shown. Mounting holes are provided on machine. If aluminum placard use #8 self-tapping screws.

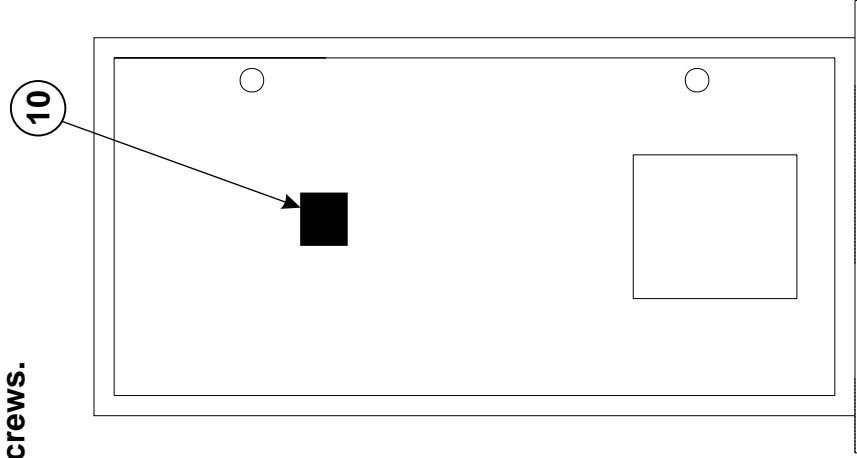

FRONT VIEW



RIGHT VIEW



Pellerin Milnor Corporation
P. O. Box 400, Kenner, LA 70063-0400

Litho in U.S.A.

Parts List—Safety Placard Placement

Find the correct assembly first, then find the needed components. The item letters (A, B, C, etc.) assigned to assemblies are referred to in the "Used In" column to identify which components belong to an assembly. The item numbers (1, 2, 3, etc.) assigned to components relate the parts list to the illustration.

Used In	Item	Part Number	Description	Comments
-----ASSEMBLIES-----				
none				
-----COMPONENTS-----				
all	10	01 10377	NPLTE:"WARNING" 4X4	

Safety Placard Use and Placement TYPICAL ALL CBW AUXILIARY TANKS

BMP040046/2004313V
(Sheet 1 of 2)



Pellerin Milnor Corporation
P. O. Box 400, Kenner, LA 70063-0400

Litho in U.S.A.

Notes:

1. Replace placard immediately, if removed or unreadable.
2. Approximate locations of placards are shown. Mounting holes are provided on machine. If aluminum placard use #8 self-tapping screws.

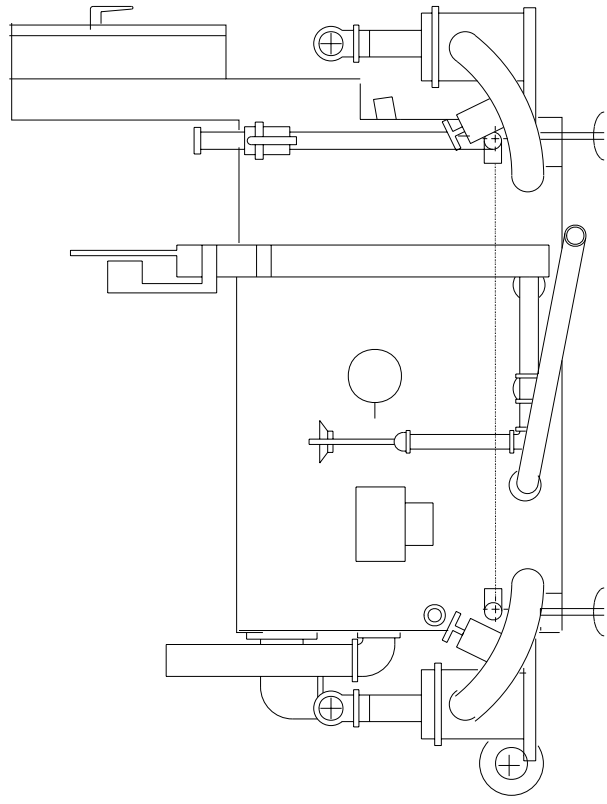

Note:
Pumps and piping will vary dependent on function.

FRONT VIEW

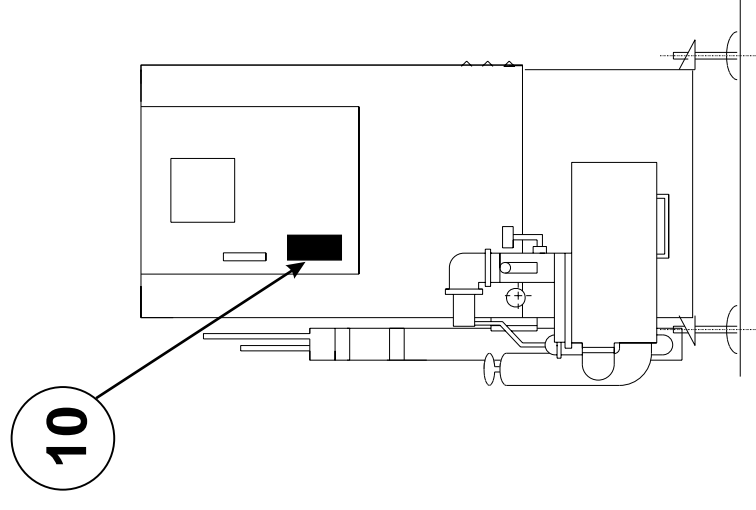

RIGHT VIEW



Pellerin Milnor Corporation
P. O. Box 400, Kenner, LA 70063-0400

Litho in U.S.A.

Parts List—Safety Placard Placement

Find the correct assembly first, then find the needed components. The item letters (A, B, C, etc.) assigned to assemblies are referred to in the "Used In" column to identify which components belong to an assembly. The item numbers (1, 2, 3, etc.) assigned to components relate the parts list to the illustration.

Used In	Item	Part Number	Description	Comments
-----ASSEMBLIES-----				
none				
-----COMPONENTS-----				
all	20	01 10375C	NPLT:E-HAZARD SM VERTCL-TCATA	

Safety Placard Use and Placement ISO Typical All CBW Auxiliary Tanks

BMP040047/2004313V
(Sheet 1 of 2)



Pellerin Milnor Corporation
P. O. Box 400, Kenner, LA 70063-0400

Litho in U.S.A.

ISO Placards shown on this page

Notes:

1. Replace placard immediately, if removed or unreadable.
2. Approximate locations of placards are shown. Mounting holes are provided on machine. If aluminum placard use #8 self-tapping screws.

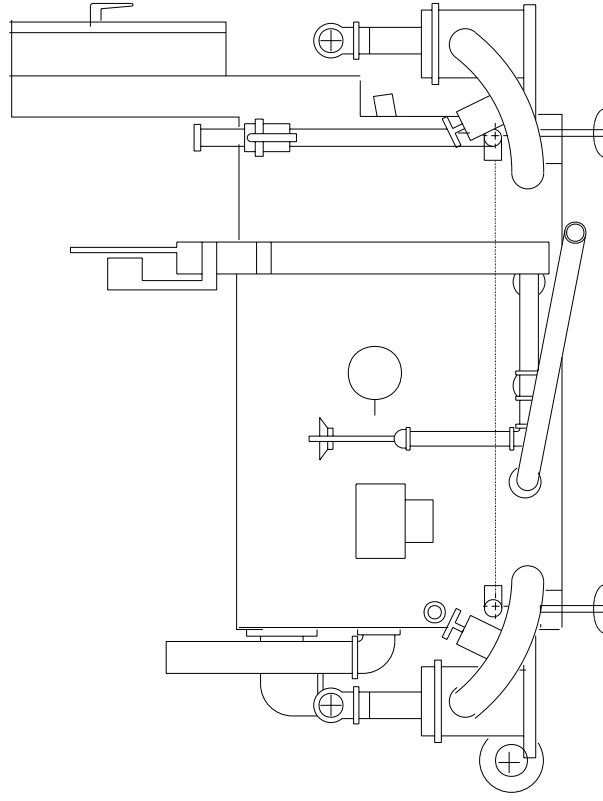
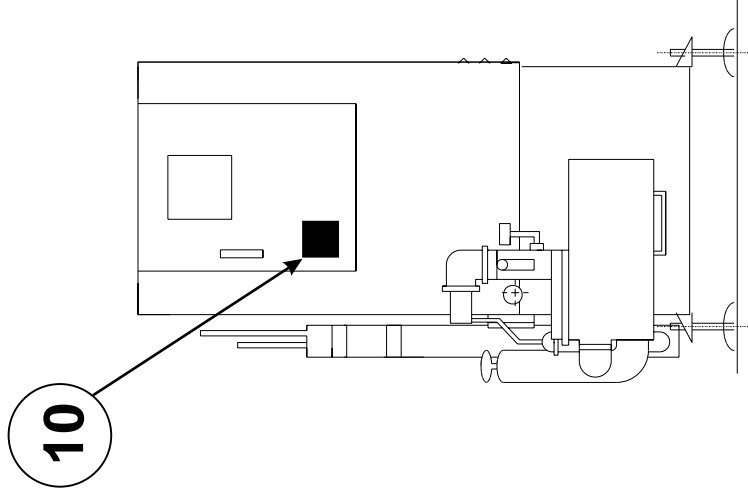

Note:
Pumps and piping will vary dependent on function.

FRONT VIEW

RIGHT VIEW



Pellerin Milnor Corporation
P. O. Box 400, Kenner, LA 70063-0400

Litho in U.S.A.

Parts List—Safety Placard Placement

Find the correct assembly first, then find the needed components. The item letters (A, B, C, etc.) assigned to assemblies are referred to in the "Used In" column to identify which components belong to an assembly. The item numbers (1, 2, 3, etc.) assigned to components relate the parts list to the illustration.

Used In	Item	Part Number	Description	Comments
-----ASSEMBLIES-----				
none				
-----COMPONENTS-----				
all	20	01 10375	NPLTE:"WARNING" 2X2	

BIUUUI02P9 (Published) Book specs- Dates: 20170824 / 20170824 / 20170824 Lang: ENG01 Applic: PC9

Tag Guidelines for the Models Listed Below

92048C1F 92048C2F 92048C3F 92048H1F 92048H2F 92048H3F

Notice 1: This information may apply to models in addition to those listed above. It applies to paper tags. It does not apply to the vinyl or metal safety placards, which must remain permanently affixed to the machine and replaced if no longer readable.

Paper tags on the machine provide installation guidelines and precautions. The tags can be tie-on or adhesive. You can remove tie-on tags and white, adhesive tags after installation. Yellow adhesive tags must remain on the machine.

Tag Guidelines for the Models Listed Below

The following entries explain the installation tags. Each entry includes: 1) the tag illustration, 2) the tag part number displayed at the bottom of the tag, and 3) the meaning of the tag.

Display or Action



Explanation

Read the manuals before proceeding. This symbol appears on most tags. The machine ships with safety, operator, and routine maintenance guides for customer use. Milnor dealer manuals for installing, servicing, and commissioning this machine are also available from the Milnor Parts department.



B2TAG88005: This carefully built product was tested and inspected to meet Milnor® performance and quality standards by (identification mark of tester).



B2TAG94078: Do not forklift here; do not jack here; do not step here—whichever applies.



B2TAG94081: Motor must rotate in this direction. On single motor washer-extractors and centrifugal extractors, the drive motor must turn in this direction during draining and extraction. This tag is usually wrapped around a motor housing. If the motor turns in the opposite direction when the machine is first tested, the electrical hookup is incorrect and must be reversed as explained in the schematic manual.

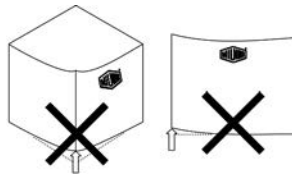

B2TAG94084: Do not lift from one corner of the machine, as this can cause the frame to rack, damaging it.

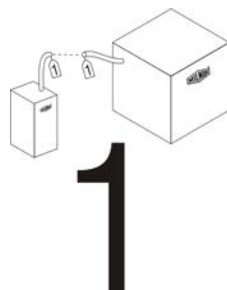

B2TAG94102 shown—others similar: Match up the components with this number. These tags are used to pair up electrical or hose connections between major components of a machine shipped dis-assembled.

Display or Action

Explanation

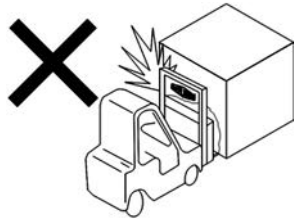

B2TAG94118: Do not strike shipping container during forklifting. Fragile components inside.

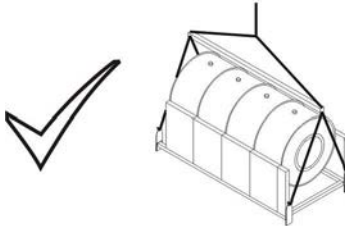

B2TAG94144: Lift tunnel units as shown, using the lifting eyes and spreader bar.



B2TAG94146: Fill with oil to this level.

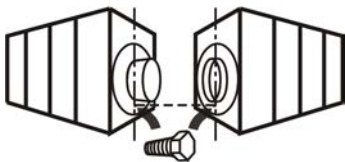

B2TAG98006: Align top dead center bolts when mating CBW tunnel washer units.

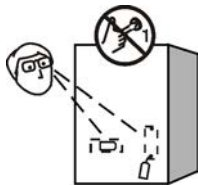

B2T2001028: Look for tags inside the machine. These tags may identify shipping restraints to be removed or components to be installed. Do not start the machine until these actions are completed.



B2T2002013: Do not start the machine until shipping restraints are removed. This tag will appear on the outside of the machine to alert you to the presence of internal shipping restraints. A tag will also appear on the restraint to help identify it. Most, but not all shipping restraints display the color red. Some shipping restraints are also safety stands. Do not discard these.

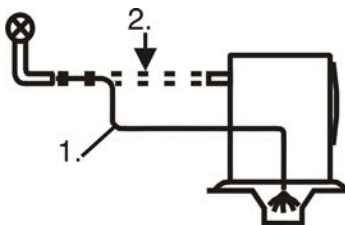
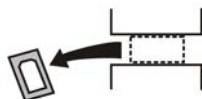

B2T2002032: Flush incoming water lines before making connections.

Tag Guidelines for the Models Listed Below

Display or Action



Explanation

B2T2003014: Make sure that you use the specified hydraulic oil.



B2T2004027: Steam connection (optional)

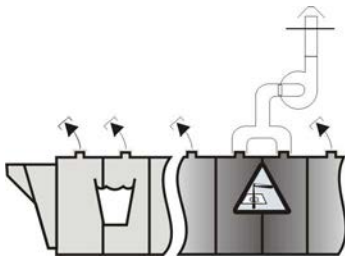

B2T2008001: Read the installation instructions. Remove temporary vent covers. Install a powered vent unit on the oxidation zone modules and a separate powered vent unit on the finish zone module and adjacent press, if there is one.

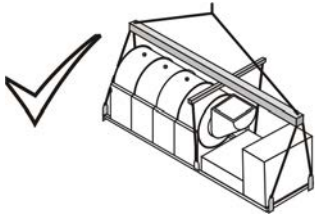

B2T2010018: Lift from all lifting points and use spreader bars as shown. (Used on PulseFlow machines only.)



B2T2010023: Set the press frame in accordance with this instruction and the installation manual.

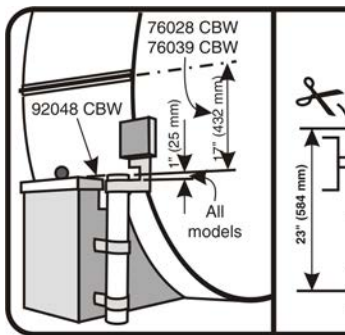

B2T2011014: Set clips on level float rods as shown.

— End of BIUUUI02 —

Prevent Damage from Chemical Supplies and Chemical Systems

BNUUUR02.C01 0000160549 B.3 E.3 1/2/20 2:14 PM Released

All Milnor® washer-extractors and CBW® tunnel washers use stainless steel with the ANSI 304 specification. This material gives good performance when chemical supplies are correctly applied. If chemical supplies are incorrectly applied, this material can be damaged. The damage can be very bad and it can occur quickly.

Chemical supply companies usually:

- supply chemical pump systems that put the supplies in the machine,
- connect the chemical pump system to the machine,
- write wash formulas that control the chemical concentrations.

The company that does these procedures must make sure that these procedures do not cause damage. **Pellerin Milnor Corporation accepts no responsibility for chemical damage to the machines it makes or to the goods in a machine.**

1. How Chemical Supplies Can Cause Damage

BNUUUR02.R01 0000160548 B.4 E.3 1/2/20 2:14 PM Released

Dangerous Chemical Supplies and Wash Formulas — Some examples that can cause damage are:

- a very high concentration of chlorine bleach,
- a mixture of acid sour and hypo chlorite,
- chemical supplies (examples: chlorine bleach, hydrofluosilicic acid) that stay on the stainless steel because they are not quickly flushed with water.

The book “Textile Laundering Technology” by Charles L. Riggs gives data about correct chemical supplies and formulas.

Incorrect Configuration or Connection of Equipment — Many chemical systems:

- do not prevent a vacuum in the chemical tube (for example, with a vacuum breaker) when the pump is off,
- do not prevent flow (for example, with a valve) where the chemical tube goes in the machine.

Damage will occur if a chemical supply can go in the machine when the chemical system is off. Some configurations of components can let the chemical supplies go in the machine by a siphon ([Figure 1: Incorrect Configurations That Let the Chemical Supply Go In the Machine by a Siphon, page 2](#)). Some can let chemical supplies go in the machine by gravity ([Figure 2: Incorrect Configurations That Let the Chemical Supply Go In the Machine by Gravity, page 3](#)).

Figure 1. Incorrect Configurations That Let the Chemical Supply Go In the Machine by a Siphon

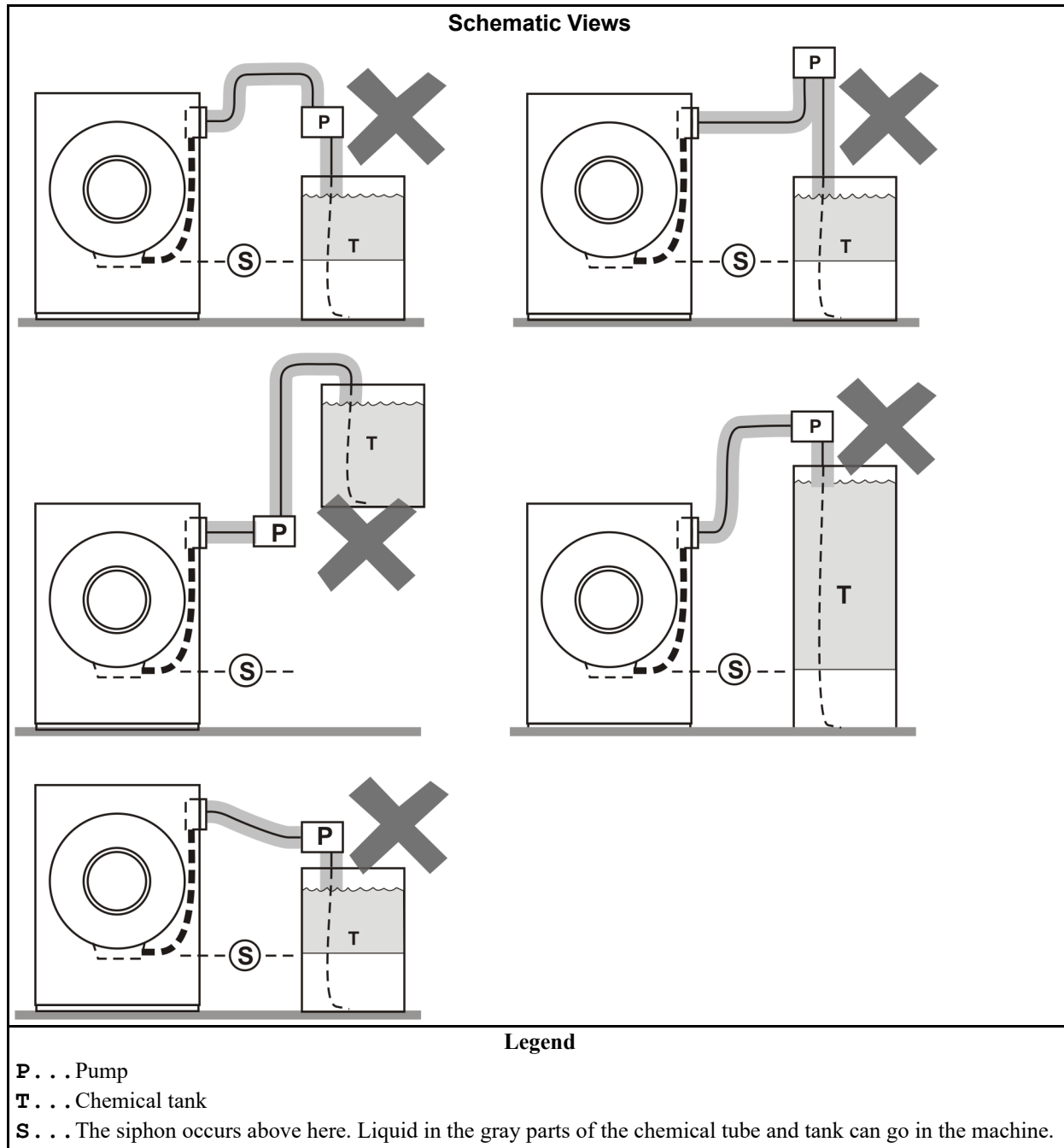
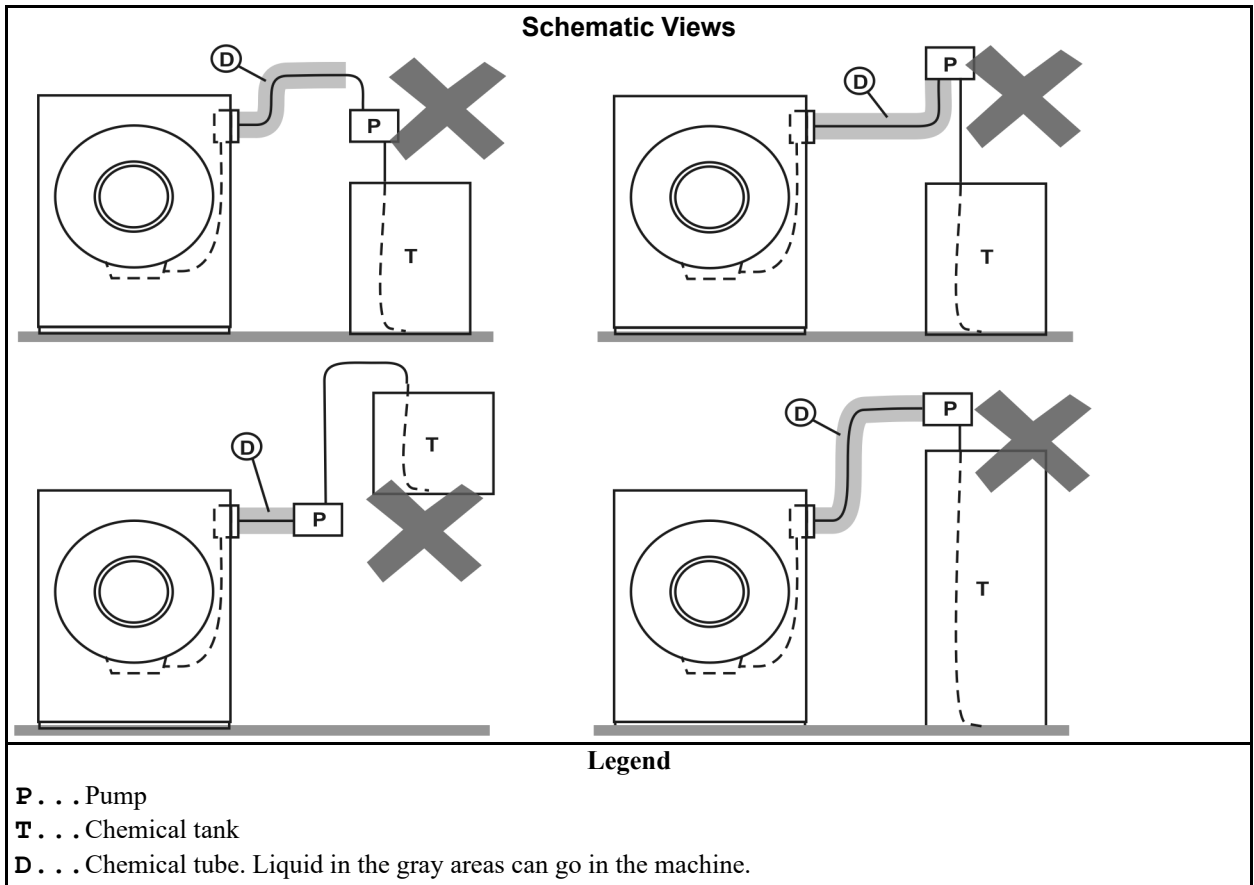

Figure 2. Incorrect Configurations That Let the Chemical Supply Go In the Machine by Gravity



2. Equipment and Procedures That Can Prevent Damage

BNUUUR02.R02 0000160545 B.3 E.3 1/2/20 2:14 PM Released

Use the chemical manifold supplied. — There is a manifold on the machine to attach chemical tubes from a chemical pump system. The manifold has a source of water to flush the chemical supplies with water.

Figure 3. Examples of Manifolds for Chemical Tubes. Your equipment can look different.



Close the line. — If the pump does not always close the line when it is off, use a shutoff valve to do this.

Do not let a vacuum occur. — Supply a vacuum breaker in the chemical line that is higher than the full level of the tank.

Flush the chemical tube with water. — If the liquid that stays in the tube between the pump and the machine can flow in the machine, flush the tube with water after the pump stops.

Put the chemical tube fully below the inlet. — It is also necessary that there is no pressure in the chemical tube or tank when the system is off.

Figure 4. A Configuration that Prevents Flow in the Machine When the Pump is Off (if the chemical tube and tank have no pressure)

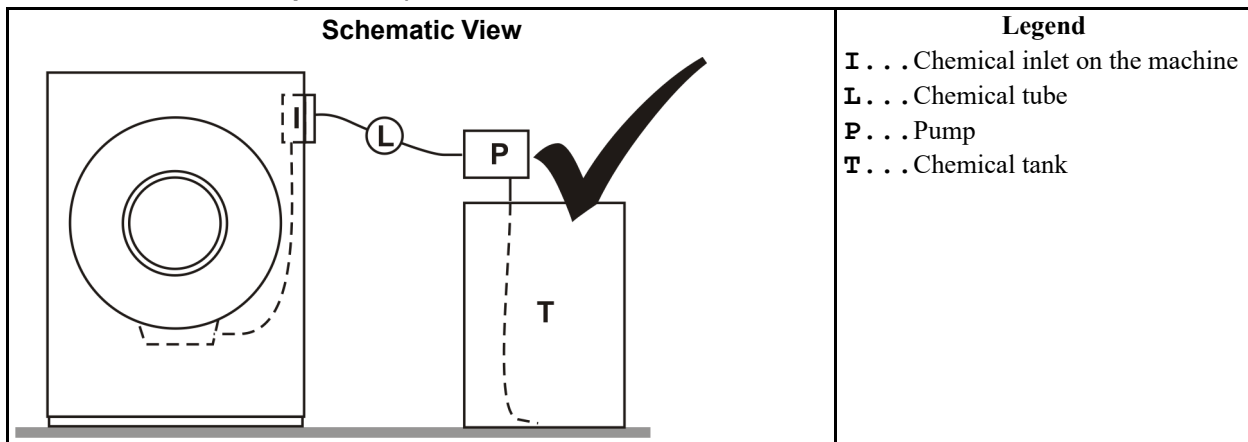

Prevent leaks. — When you do maintenance on the chemical pump system:

- Use the correct components.
- Make sure that all connections are the correct fit.
- Make sure that all connections are tight.

End of document: BNUUUR02

Torque Requirements for Fasteners



This document uses Simplified Technical English. Learn more at <http://www.asd-ste100.org>.

The document about the assembly gives the torque requirements for other fasteners. **If fastener torque specifications or threadlocker requirements in an assembly document are different from this document, use the assembly document.**

Figure 1: The Bolts in Milnor® Equipment

The Marks on Bolt Heads	Legend
	<p>A. SAE Grades 1 and 2, ASTM A307, and stainless steel</p> <p>B. Grade BC, ASTM A354</p> <p>C. SAE Grade 5, ASTM A449</p> <p>D. SAE Grade 8 and ASTM A354 BD</p>

1. Torque Values

These tables give the standard dimension, grade, threadlocker, and torque requirements for fasteners frequently used on Milnor® equipment.

Note 1: Data from the Pellerin Milnor® Corporation “Bolt Torque Specification” (bolt_torque_milnor.xls/2002096).

1.1. Fasteners Made of Carbon Steel

1.1.1. Without a Threadlocker

Table 1: Torque Values for Standard Fasteners with Maximum 5/16-inch Diameters and No Lubricant

Dimension	The Grade of the Bolt							
	Grade 2		Grade 5		Grade 8		Grade BC	
	Pound-Inches	N-m	Pound-Inches	N-m	Pound-Inches	N-m	Pound-Inches	N-m
1/4 x 20	66	7	101	11	143	16	126	14
1/4 x 28	76	9	116	13	163	18	--	--
5/16 x 18	136	15	209	24	295	33	258	29
5/16 x 24	150	17	232	26	325	37	--	--

Torque Requirements for Fasteners

Table 2: Torque Values for Standard Fasteners Larger Than 5/16-inch Diameters and No Lubricant

Dimension	The Grade of the Bolt							
	Grade 2		Grade 5		Grade 8		Grade BC	
	Pound-feet	N-m	Pound-feet	N-m	Pound-feet	N-m	Pound-feet	N-m
3/8 x 16	20	27	31	42	44	59	38	52
3/8 x 24	23	31	35	47	50	68	--	--
7/16 x 14	32	43	49	66	70	95	61	83
7/16 x 20	36	49	55	75	78	105	--	--
1/2 x 13	49	66	75	102	107	145	93	126
1/2 x 20	55	75	85	115	120	163	--	--
9/16 x 12	70	95	109	148	154	209	134	182
9/16 x 18	78	106	121	164	171	232	--	--
5/8 x 11	97	131	150	203	212	287	186	252
5/8 x 18	110	149	170	231	240	325	--	--
3/4 x 10	172	233	266	361	376	510	329	446
3/4 x 16	192	261	297	403	420	569	--	--
7/8 x 9	167	226	429	582	606	821	531	719
7/8 x 14	184	249	473	641	668	906	--	--
1 x 8	250	339	644	873	909	1232	796	1079
1 x 12	274	371	704	954	994	1348	--	--
1 x 14	281	381	723	980	1020	1383	--	--
1 1/8 x 7	354	480	794	1077	1287	1745	1126	1527
1 1/8 x 12	397	538	891	1208	1444	1958	--	--
1 1/4 x 7	500	678	1120	1519	1817	2464	1590	2155
1 1/4 x 12	553	750	1241	1682	2012	2728	--	--
1 3/8 x 6	655	888	1469	1992	2382	3230	2085	2827
1 3/8 x 12	746	1011	1672	2267	2712	3677	--	--
1 1/2 x 6	869	1178	1949	2642	3161	4286	2767	3751
1 1/2 x 12	979	1327	2194	2974	3557	4822	--	--

Table 3: Torque Values for Plated Fasteners with Maximum 5/16-inch Diameters and No Lubricant

Dimension	The Grade of the Bolt							
	Grade 2		Grade 5		Grade 8		Grade BC	
	Pound-Inches	N-m	Pound-Inches	N-m	Pound-Inches	N-m	Pound-Inches	N-m
1/4 x 20	49	6	76	9	107	12	95	11
1/4 x 28	56	6	88	10	122	14	--	--
5/16 x 18	102	12	156	18	222	25	193	22
5/16 x 24	113	13	174	20	245	28	--	--

Table 4: Torque Values for Plated Fasteners Larger Than 5/16-inch Diameters and No Lubricant

Dimension	The Grade of the Bolt							
	Grade 2		Grade 5		Grade 8		Grade BC	
	Pound-feet	N-m	Pound-feet	N-m	Pound-feet	N-m	Pound-feet	N-m
3/8 x 16	15	20	23	31	33	44	29	38
3/8 x 24	17	23	26	35	37	49	--	--
7/16 x 14	24	32	37	50	52	71	46	61
7/16 x 20	27	36	41	55	58	78	--	--
1/2 x 13	37	49	56	76	80	106	70	93
1/2 x 20	41	55	64	85	90	120	--	--
9/16 x 12	53	70	81	110	115	153	101	134
9/16 x 18	59	79	91	122	128	174	--	--
5/8 x 11	73	97	113	150	159	212	139	186
5/8 x 18	83	110	127	172	180	240	--	--
3/4 x 10	129	173	200	266	282	376	246	329
3/4 x 16	144	192	223	297	315	420	--	--
7/8 x 9	125	166	322	430	455	606	398	531
7/8 x 14	138	184	355	474	501	668	--	--
1 x 8	188	250	483	644	682	909	597	796
1 x 12	205	274	528	716	746	995	--	--
1 x 14	210	280	542	735	765	1037	--	--
1 1/8 x 7	266	354	595	807	966	1288	845	1126
1 1/8 x 12	298	404	668	890	1083	1444	--	--
1 1/4 x 7	375	500	840	1120	1363	1817	1192	1590
1 1/4 x 12	415	553	930	1261	1509	2013	--	--
1 3/8 x 6	491	655	1102	1470	1787	2382	1564	2085
1 3/8 x 12	559	758	1254	1672	2034	2712	--	--
1 1/2 x 6	652	870	1462	1982	2371	3161	2075	2767
1 1/2 x 12	733	994	1645	2194	2668	3557	--	--

1.1.2. With a Threadlocker

Table 5: Threadlocker by the Diameter of the Bolt (see Note 2)

LocTite Product	Dimension			
	1/4-inch	1/4- to 5/8-inch	5/8- to 7/8-inch	1-inch +
LocTite 222	OK			
LocTite 242		OK		
LocTite 262			OK	
LocTite 272			High temperature	
LocTite 277				OK

Note 2: The acceptable bolt size ranges for various LocTite® threadlocking products is the LocTite manufacturer's **general** recommendation. Specific applications sometime require that a LocTite product is applied to a bolt size outside the ranges shown here. For example, Milnor specifies LocTite 242 for use on certain 1" bolt applications and has confirmed this usage with the LocTite manufacturer. You may see variances such as this in the documentation for specific machine assemblies.

Torque Requirements for Fasteners

Table 6: Torque Values if You Apply LocTite 222

Dimension	The Grade of the Bolt							
	Grade 2		Grade 5		Grade 8		Grade BC	
	Pound-inches	N-m	Pound-inches	N-m	Pound-inches	N-m	Pound-inches	N-m
1/4 x 20	60	7	96	11	132	15	108	12
1/4 x 28	72	8	108	12	144	16	--	--

Table 7: Torque Values if You Apply LocTite 242

Dimension	The Grade of the Bolt							
	Grade 2		Grade 5		Grade 8		Grade BC	
	Pound-feet	N-m	Pound-feet	N-m	Pound-feet	N-m	Pound-feet	N-m
5/16 x 18	11	15	17	23	25	34	22	30
5/16 x 24	13	18	19	26	27	37	27	37
3/8 x 16	20	27	31	42	44	60	38	52
3/8 x 24	23	31	35	47	50	68	--	--
7/16 x 14	32	43	49	66	70	95	61	83
7/16 x 20	36	49	55	75	78	106	--	--
1/2 x 13	49	66	75	102	107	145	93	126
1/2 x 20	55	75	85	115	120	163	--	--
9/16 x 12	70	95	109	148	154	209	134	182
9/16 x 18	78	106	121	164	171	232	--	--
5/8 x 11	97	132	150	203	212	287	186	252
5/8 x 18	110	149	170	230	240	325	--	--

Table 8: Torque Values if You Apply LocTite 262

Dimension	The Grade of the Bolt							
	Grade 2		Grade 5		Grade 8		Grade BC	
	Pound-feet	N-m	Pound-feet	N-m	Pound-feet	N-m	Pound-feet	N-m
3/4 x 10	155	210	240	325	338	458	296	401
3/4 x 16	173	235	267	362	378	512	--	--
7/8 x 9	150	203	386	523	546	740	477	647
7/8 x 14	165	224	426	578	601	815	--	--

Table 9: Torque Values if You Apply LocTite 272 (High-Temperature)

Dimension	The Grade of the Bolt							
	Grade 2		Grade 5		Grade 8		Grade BC	
	Pound-feet	N-m	Pound-feet	N-m	Pound-feet	N-m	Pound-feet	N-m
1 x 8	350	475	901	1222	1272	1725	1114	1510
1 x 12	383	519	986	1337	1392	1887	--	--
1 x 14	393	533	1012	1372	1428	1936	--	--
1-1/8 x 7	496	672	1111	1506	1802	2443	1577	2138
1-1/8 x 12	556	754	1247	1691	2022	2741	--	--
1-1/4 x 7	700	949	1568	2126	2544	3449	2226	3018
1-1/4 x 12	774	1049	1737	2355	2816	3818	--	--
1-3/8 x 6	917	1243	2056	2788	3335	4522	2919	3958
1-3/8 x 12	1044	1415	2341	3174	3797	5148	--	--
1-1/2 x 6	1217	1650	2729	3700	4426	6001	3873	5251
1-1/2 x 12	1369	1856	3071	4164	4980	6752	--	--

Table 10: Torque Values if You Apply LocTite 277

Dimension	The Grade of the Bolt							
	Grade 2		Grade 5		Grade 8		Grade BC	
	Pound-feet	N-m	Pound-feet	N-m	Pound-feet	N-m	Pound-feet	N-m
1 x 8	325	441	837	1135	1181	1601	1034	1402
1 x 12	356	483	916	1242	1293	1753	--	--
1 x 14	365	495	939	1273	1326	1798	--	--
1-1/8 x 7	461	625	1032	1399	1674	2270	1464	1985
1-1/8 x 12	516	700	1158	1570	1877	2545	--	--
1-1/4 x 7	650	881	1456	1974	2362	3202	2067	2802
1-1/4 x 12	719	975	1613	2187	2615	3545	--	--
1-3/8 x 6	851	1154	1909	2588	3097	4199	2710	3674
1-3/8 x 12	970	1315	2174	2948	3526	4781	--	--
1-1/2 x 6	1130	1532	2534	3436	4110	5572	3597	4877
1-1/2 x 12	1271	1723	2852	3867	4624	6269	--	--

1.2. Stainless Steel Fasteners

Table 11: Torque Values for Stainless Steel Fasteners 5/16-inch and Smaller

Dimension	316 Stainless		18-8 Stainless		18-8 Stainless with Loctite 767	
	Pound-Inches	N-m	Pound-Inches	N-m	Pound-Inches	N-m
1/4 x 20	79	9	76	9	45	5
1/4 x 28	100	11	94	11	56	6
5/16 x 18	138	16	132	15	79	9
5/16 x 24	148	17	142	16	85	10

Table 12: Torque Values for Stainless Steel Fasteners Larger Than 5/16-inch

Dimension	316 Stainless		18-8 Stainless		18-8 Stainless with Loctite 767	
	Pound-feet	N-m	Pound-feet	N-m	Pound-feet	N-m
3/8 x 16	21	28	20	27	12	16
3/8 x 24	23	31	22	29	13	18
7/16 x 14	33	44	31	42	19	25
7/16 x 20	35	47	33	45	20	27
1/2 x 13	45	61	43	58	26	35
1/2 x 20	47	64	45	61	27	37
9/16 x 12	59	81	57	77	34	46
9/16 x 18	66	89	63	85	38	51
5/8 x 11	97	131	93	125	56	75
5/8 x 18	108	150	104	141	62	84
3/4 x 10	132	179	128	173	77	104
3/4 x 16	130	176	124	168	75	101
7/8 x 9	203	275	194	263	116	158
7/8 x 14	202	273	193	262	116	157
1 x 8	300	406	287	389	172	233
1 x 14	271	367	259	351	156	211
1-1/8 x 7	432	586	413	560	248	336
1-1/8 x 12	408	553	390	529	234	317
1-1/4 x 7	546	740	523	709	314	425
1-1/4 x 12	504	683	480	651	288	390
1-1/2 x 6	930	1261	888	1204	533	722
1-1/2 x 12	732	992	703	953	422	572

2. Preparation



WARNING 2: Fire Hazard—Some solvents and primers are flammable.

- Use threadlocker and primers with sufficient airflow.
 - Do not use flammable material near ignition sources.
1. Clean all threads with a wire brush or a different tool.
 2. Remove the grease from the fasteners and the mating threads with solvent. Make the parts dry.

Note 3: Loctite 7649 Primer™ or standard solvents will remove grease from parts.

3. Apply a spray of Loctite 7649 Primer™ or equal on the fasteners and the mating threads. Let the primer dry for one minute minimum.

3. How to Apply a Threadlocker



CAUTION 3: Malfunction Hazard—Heat, vibration, or mechanical shocks can let the fasteners loosen if you do not apply the threadlocker correctly. Loose fasteners can cause malfunctions of the equipment.

- Read the threadlocker manufacturer's instructions and warnings. Obey these instructions.

Apply the threadlocker only to the areas where the fastener threads and the mating threads engage.

Figure 2: Blind Hole

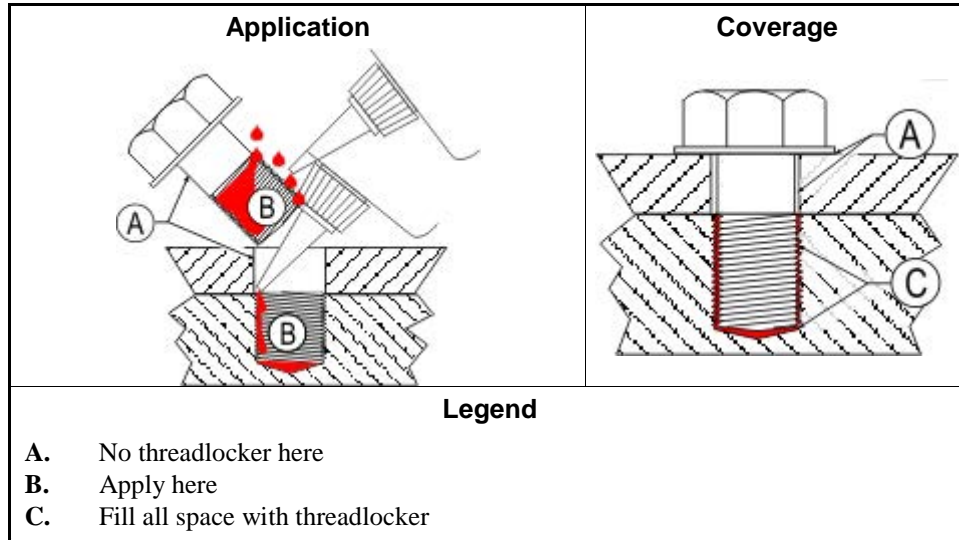

3.1. Blind Holes

1. Apply the threadlocker down the threads to the bottom of the hole.
2. Apply the threadlocker to the bolt.
3. Tighten the bolt to the value shown in the correct table ([Table 5](#) to [Table 11](#)).

3.2. Through Holes

1. Put the bolt through the assembly.
2. Apply the threadlocker only to the bolt thread area that will engage the nut.
3. Tighten the bolt to the value shown in the correct table ([Table 5](#) to [Table 11](#)).

Figure 3: Through Hole

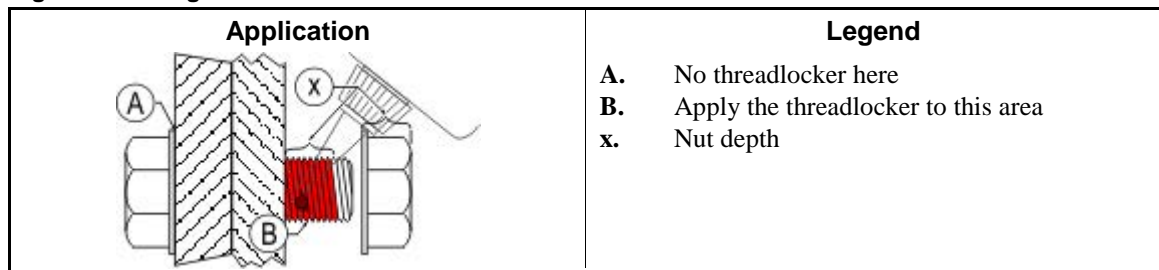

- 3.3. Disassembly**—For high-strength threadlocker, apply heat for five minutes. Disassemble with hand tools while the parts are hot.

For low-strength and moderate-strength threadlocker, disassemble with hand tools.

Figure 4: Disassembly

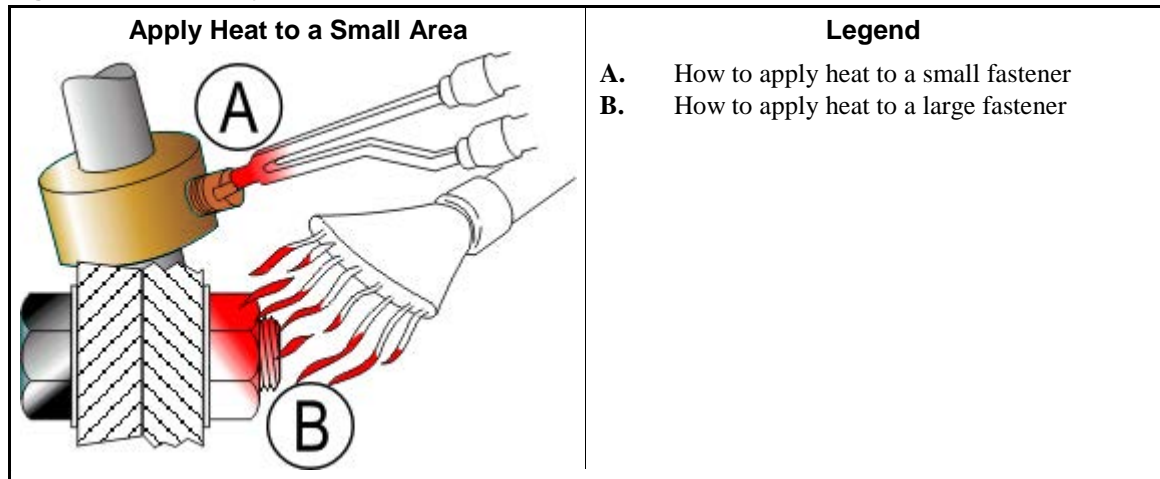

— End of BIUUM04 —

Parts and Assemblies

2

2

Drive Assemblies

2.1

Drive Chart

92048G4 Tunnels

BMP110065/2011484A
(1 / 3)



Pellerin Milnor Corporation
P. O. Box 400, Kenner, LA 70063-0400

Litho in U.S.A.



Drive Chart
92048G4 Tunnels

BMP110065/2011484A
 (2 / 3)



Pellerin Milnor Corporation
 P. O. Box 400, Kenner, LA 70063-0400

Litho in U.S.A.

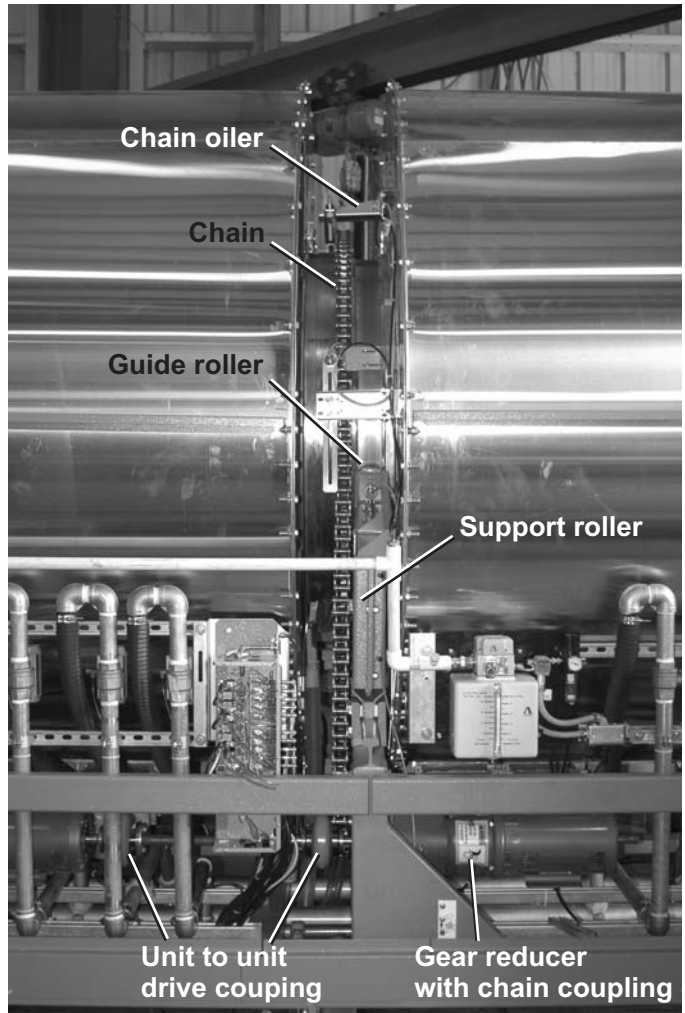
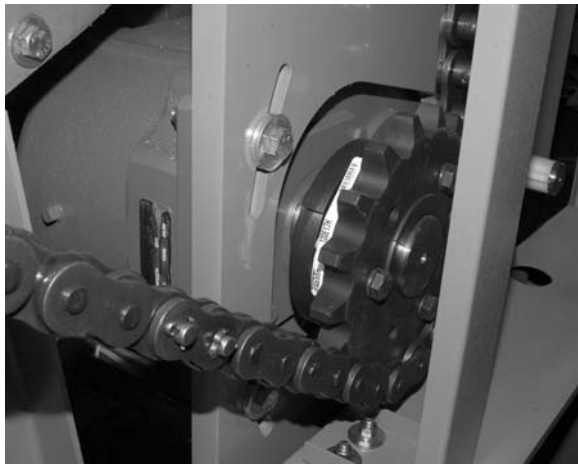
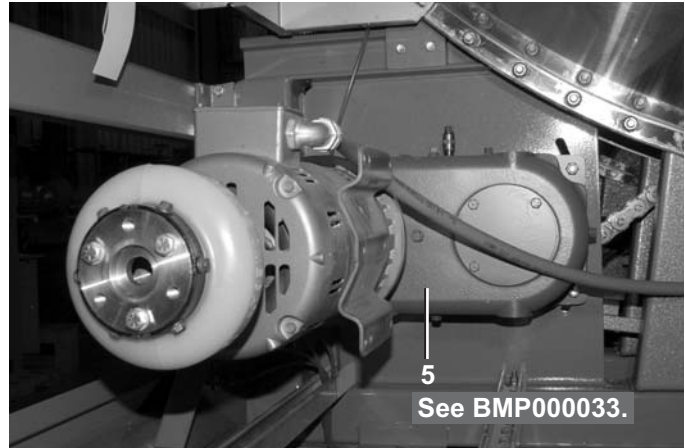
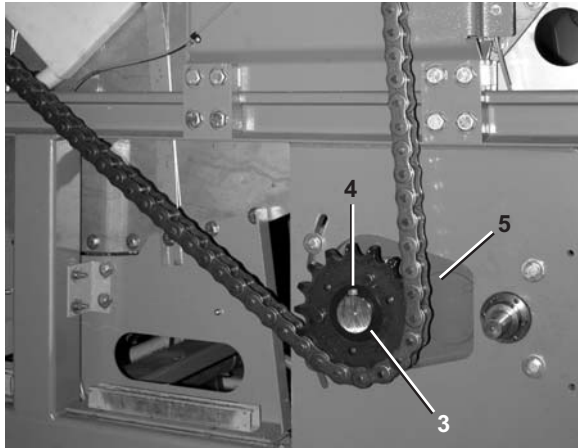



Pellerin Milnor Corporation
P. O. Box 400, Kenner, LA 70063-0400

Litho in U.S.A.

Parts List—Drive Chart

Find the correct assembly first, then find the needed components. The item letters (A, B, C, etc.) assigned to assemblies are referred to in the "Used In" column to identify which components belong to an assembly. The item numbers (1, 2, 3, etc.) assigned to components relate the parts list to the illustration.

Used In	Item	Part Number	Description	Comments
			-----ASSEMBLIES-----	
	A	GDB63001	9248 DRIVE INSTALL	
			-----COMPONENTS-----	
all	1	06 30004	9248 CBW SPROCKET	
all	2	54N120E17H	SPRKT 120E17H QD HARDENEDTEETH	
all	3	56Q2KE	2+1/2" BUSH VPUL QD TYPE E	
all	4	15E241	SQMACHKEY 5/8X2+1/2	
all	5	54S027	MILNOR, 24.59:1 180TC,12.5HP	
all	6	54G120HR	ROLLCHAIN RC120HKR 150 PITCH	
all	7	20H011CG	ALVANIA CG1 GREASE EA=1 TUBE	

Gear Reducer with Chain Coupling

76028 & 76039 G3 , **9248 G4** Tunnels

BMP000033/2010052B
(Sheet 1 of 2)



Pellerin Milnor Corporation
P. O. Box 400, Kenner, LA 70063-0400

Litho in U.S.A.

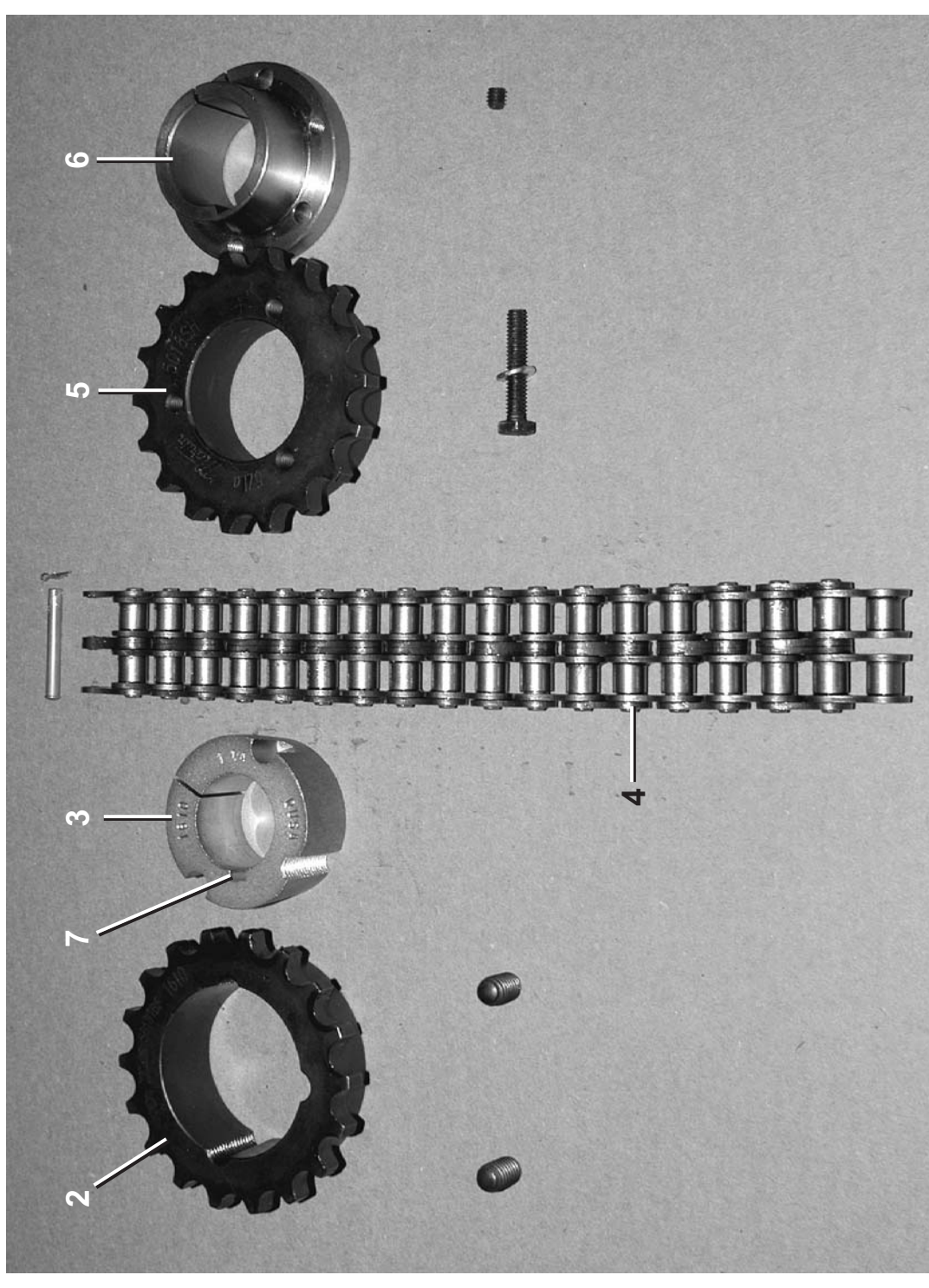
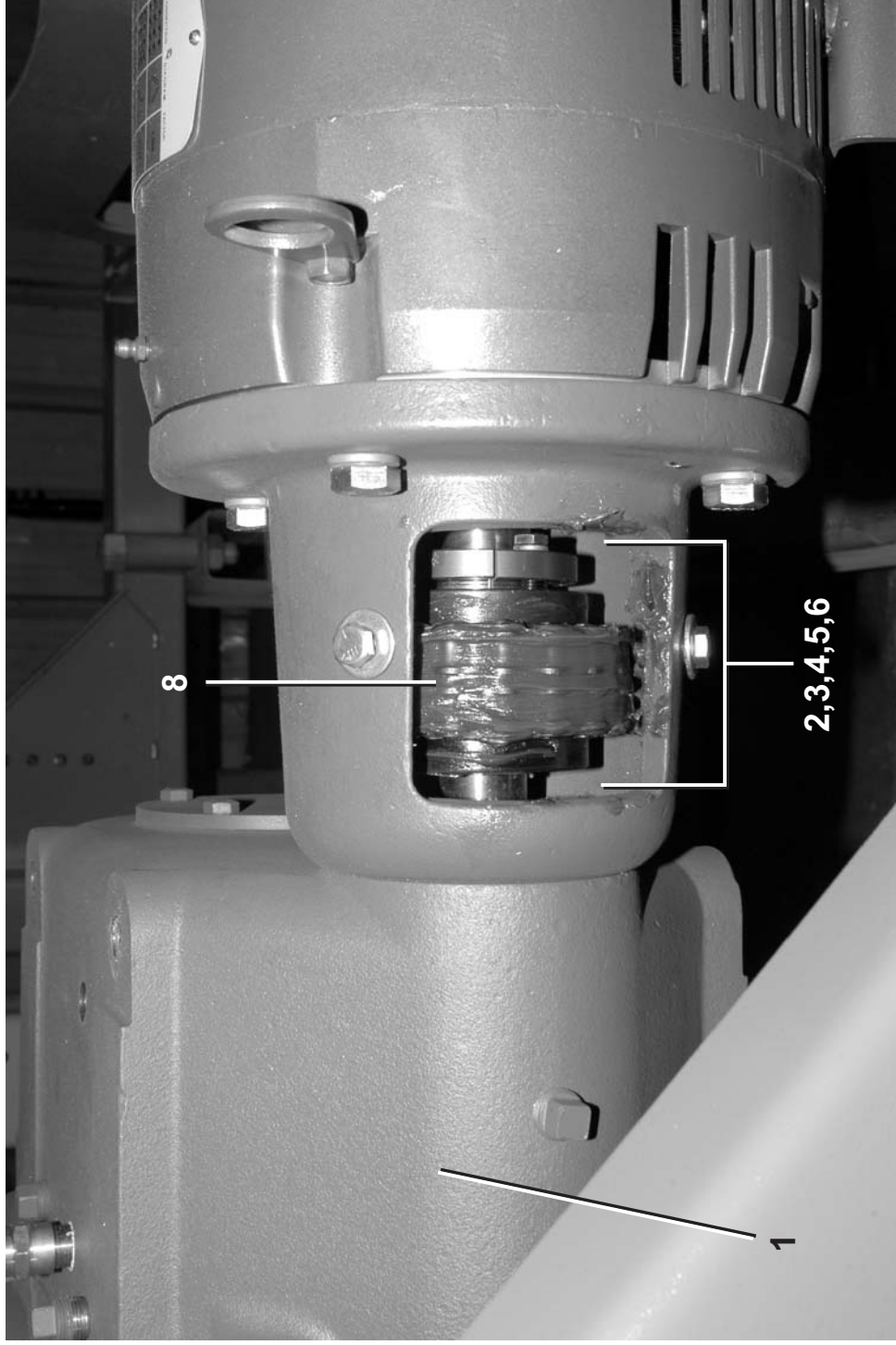

For detailed instructions of replacing the drive chain coupling, see document BIPCLM01, found within this manual.



Pellerin Milnor Corporation
P. O. Box 400, Kenner, LA 70063-0400

Litho in U.S.A.

Parts List—Gear Reducer with Chain Coupling

Find the correct assembly first, then find the needed components. The item letters (A, B, C, etc.) assigned to assemblies are referred to in the "Used In" column to identify which components belong to an assembly. The item numbers (1, 2, 3, etc.) assigned to components relate the parts list to the illustration.

Used In	Item	Part Number	Description	Comments
-----ASSEMBLIES-----				
	A	A67DB001	20HP REDUCER/10HP MOTOR ASSY	FIRST & LAST MODULES
	B	A67DB002	10HP REDUCER/05HP MOTOR ASSY	MIDDLE MODULES
	C	A67DB003	10HP REDUCER/06HP MOTOR ASSY	9248
-----COMPONENTS-----				
A	1	54S029	MILNOR, 24.59:1 210TC 23HP	
BC	1	54S027	MILNOR, 24.59:1 180TC,12.5HP	
all	2	27E5511D	FLEX.COUP.=5018TBF COUPLING	
all	3	27E5511E	1610 1 1/4" BORE BUSHING	
all	4	27E5511C	FLEX.COUP.-CHAIN=5018CHN	
all	5	27E5511A	QD-FLEX.COUP.=5018SH 1+3/8MAX.	
A	6	56Q1GSH	1+3/8" BUSH VPUL QD TYPE SH	
BC	6	56Q1CSH	1+1/8" BUSH VPUL QD TYPE SH	
all	7	15E197	1/4X1/4X1SQMACHKEY N0 TAPR/HD	
all	8	20H011CG	ALVANIA CG1 GREASE EA=1 TUBE	

Instructions for Replacing G3 Drive Chain Couplings: Retrofit Kits KTG3SCR001 and KTG3SCR002

Milnor engineers recently re-engineered the motor-to-gear reducer drive chain couplings to ensure longer life and greater reliability for these components. These new couplings can be easily retrofitted to existing G3 Continuous Batch Washers as detailed below.



WARNING 1: Entangle and Crush Hazard—Gears and chains can entangle and crush body parts

- Lock OFF and tag out power at the wall disconnect before servicing.
1. Place the key in shaft. Check for proper fit. Key must fit snugly. If not, replace the key or bushing.
 2. Slide the taper bushing on the motor shaft (Figure 1).
 3. Position taper bushing on motor shaft as follows:
 - For 10 horsepower motors, place the bushing flush with motor shaft end (Figure 2).
 - For 5 horsepower motors, place the bushing slightly back from motor shaft end so that 1/8" (3 mm) of the motor shaft extends beyond the bushing.
 4. Apply Loctite® 242 (or equivalent) to set screw (Figure 3). Tighten set screw (Figure 4).
 5. Prevent the shaft key from moving by notching the edges of the keyway (Figure 5).
 6. Install the motor sprocket on the bushing (Figure 6).
 7. Gradually tighten the bushing bolts in an alternating pattern until the sprocket seats on the bushing. Repeat the tightening pattern at least three times. Torque bushing bolts to 108 inch-pounds (1.25 kg/cm) (Figure 7). Use a pipe wrench on the bushing to prevent the sprocket from turning during the tightening procedure.
 8. Install the gear reducer sprocket. Position sprocket on shaft but do not tighten set screw. The final position is determined when the double drive chain is installed (Figure 8).
 9. Place wooden boards on the machine frame to support the motor as shown in Figure 9. Slide motor into place and bolt up.
 10. Install a wire wrap or wire leader through the first chain link pair (Figure 10). Note the three chain plates, and master link assembly.
 11. Align motor sprocket teeth with the gear reducer sprocket teeth so that the chain links will fit between both sets of teeth.
 12. Thread chain into sprockets (Figure 11). Use the leader to help feed chain around sprockets.
 13. Ensure that the double drive chain is perfectly seated on both sprockets by adjusting the position of gear reducer sprockets. Tighten the set screw after determining the optimum gear reducer sprocket position (Figure 13).
 14. Cut off leader and partially insert the master link (Figure 14).
 15. Install the center plates between the adjoining links (Figure 15).
 16. Push the master link through the center plates (Figure 16). Install end plate and lock clip.

Figure 1: Sliding taper bushing on motor sprocket

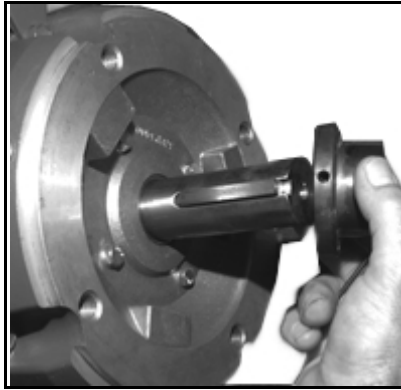

Figure 2: Aligning taper bushing with motor drive shaft (10 HP motor installation shown)

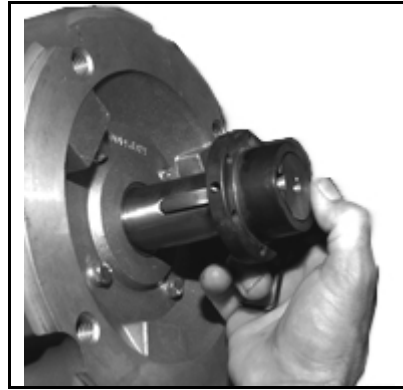

Figure 3: Applying Loctite® to taper bushing set screw

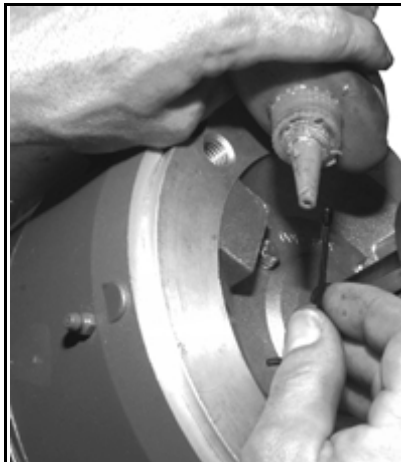

Figure 4: Securing taper bushing

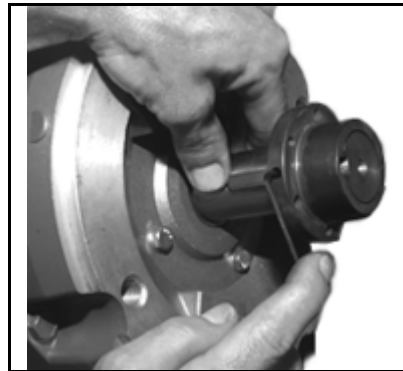

Figure 5: Notch motor shaft keyway

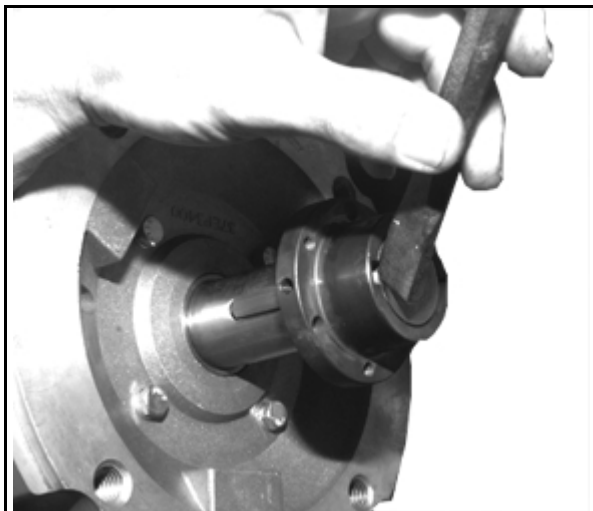

Figure 6: Fitting motor sprocket to bushing

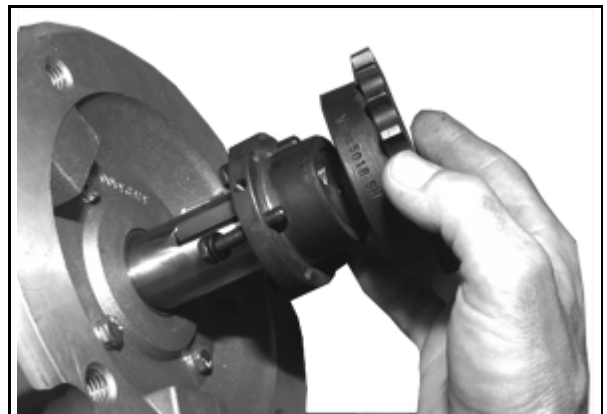

Figure 7: Tightening the motor sprocket

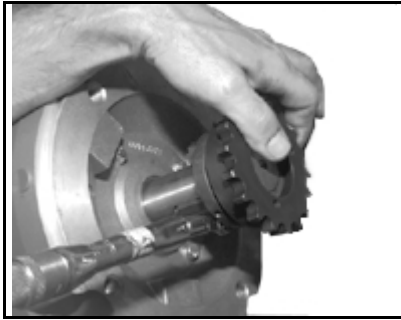

Figure 8: Positioning the gear reducer sprocket

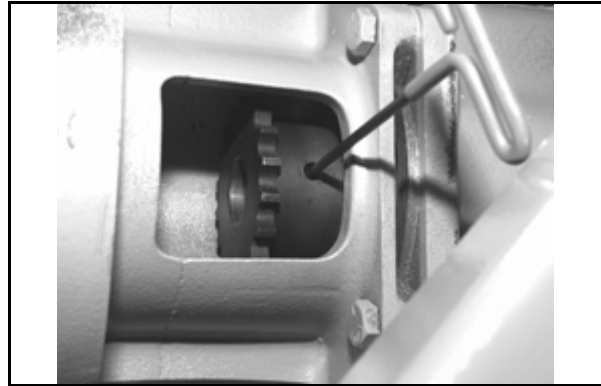

Figure 9: Sliding motor into gear reducer



Figure 10: Attaching wire wrap leader to drive chain for threading

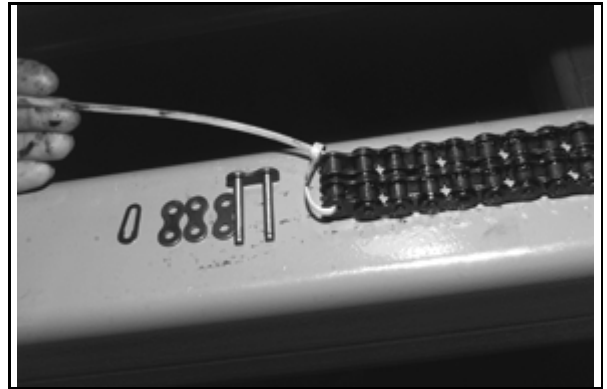

Figure 11: Starting chain into sprockets



Figure 12: Feeding chain through sprockets

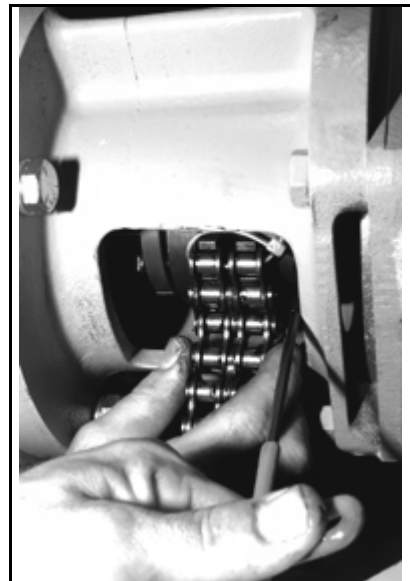

Figure 13: Double drive chain seated on sprockets

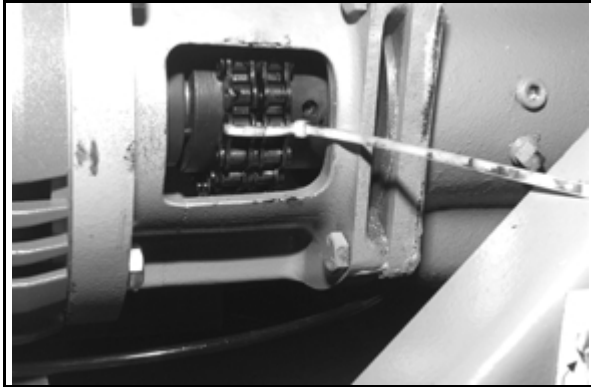

Figure 14: Partially installed master link

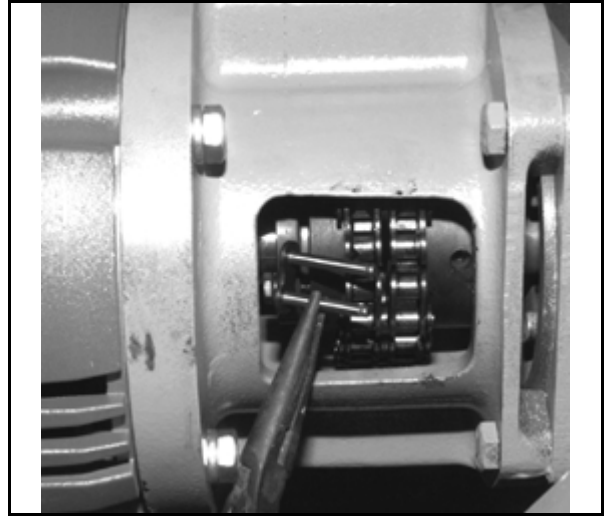

Figure 15: Installing center plates

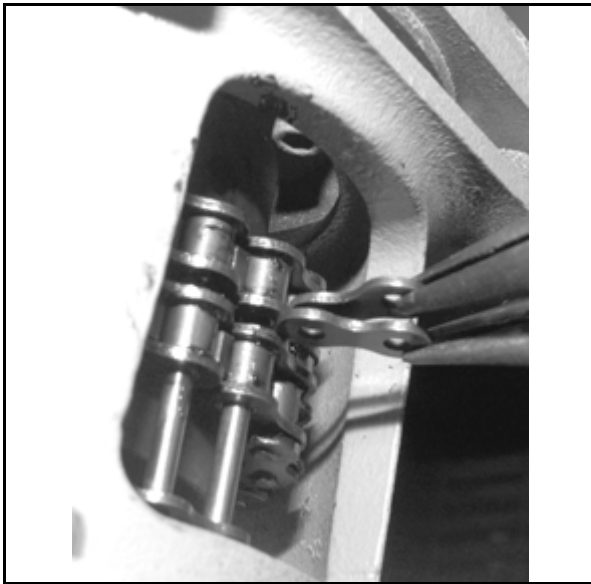
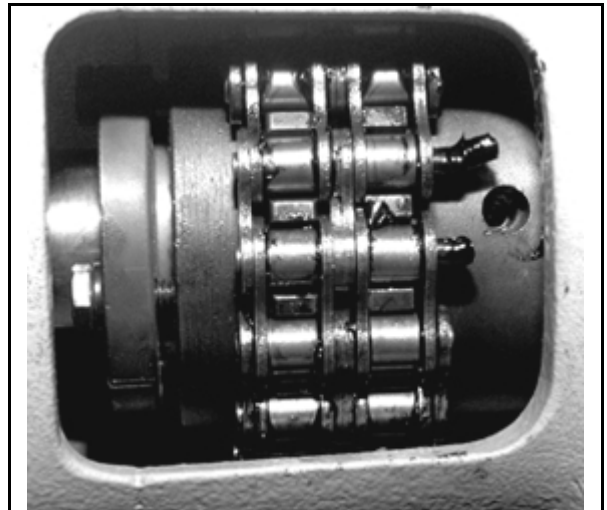

Figure 16: Center plates in position



— End of BIPCLM01 —

Drive Connections

92048G4 Tunnel

BMP110066/2011512A
(1 / 3)



Pellerin Milnor Corporation
P. O. Box 400, Kenner, LA 70063-0400

Litho in U.S.A.

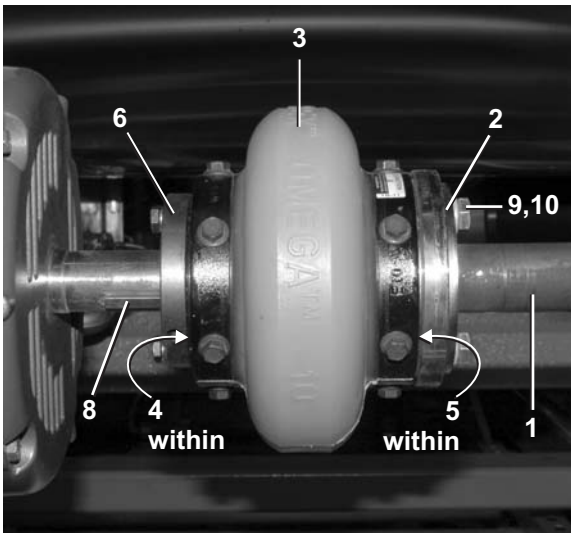
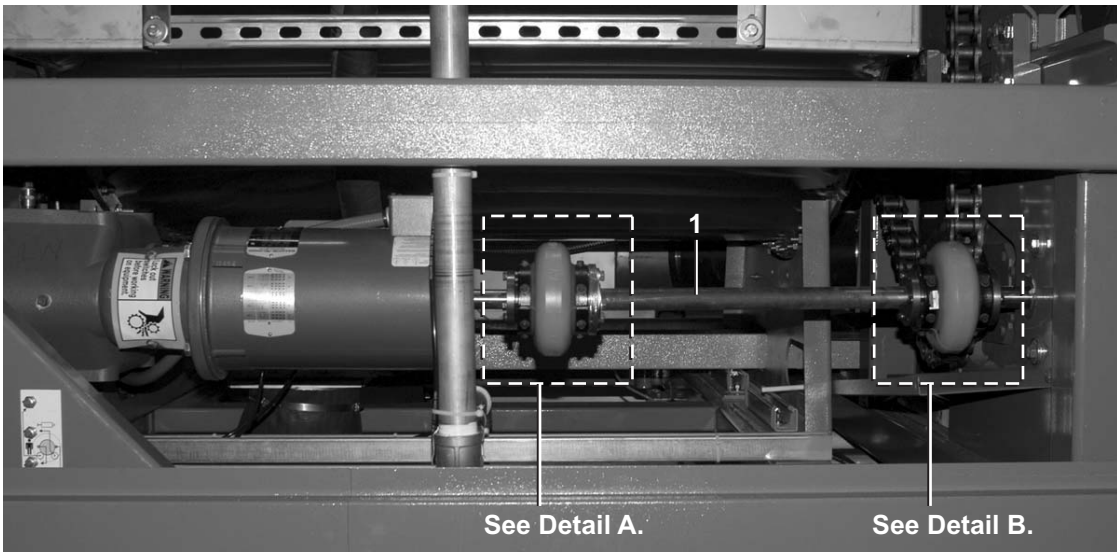

Detail A: Drive Sprocket

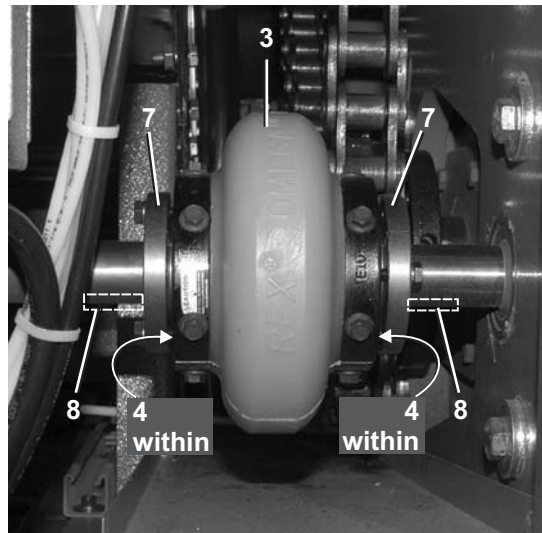

Detail B: Drive Sprocket

Drive Connections

92048G4 Tunnel

BMP110066/2011512A
(2 / 3)



Pellerin Milnor Corporation
P. O. Box 400, Kenner, LA 70063-0400

Litho in U.S.A.

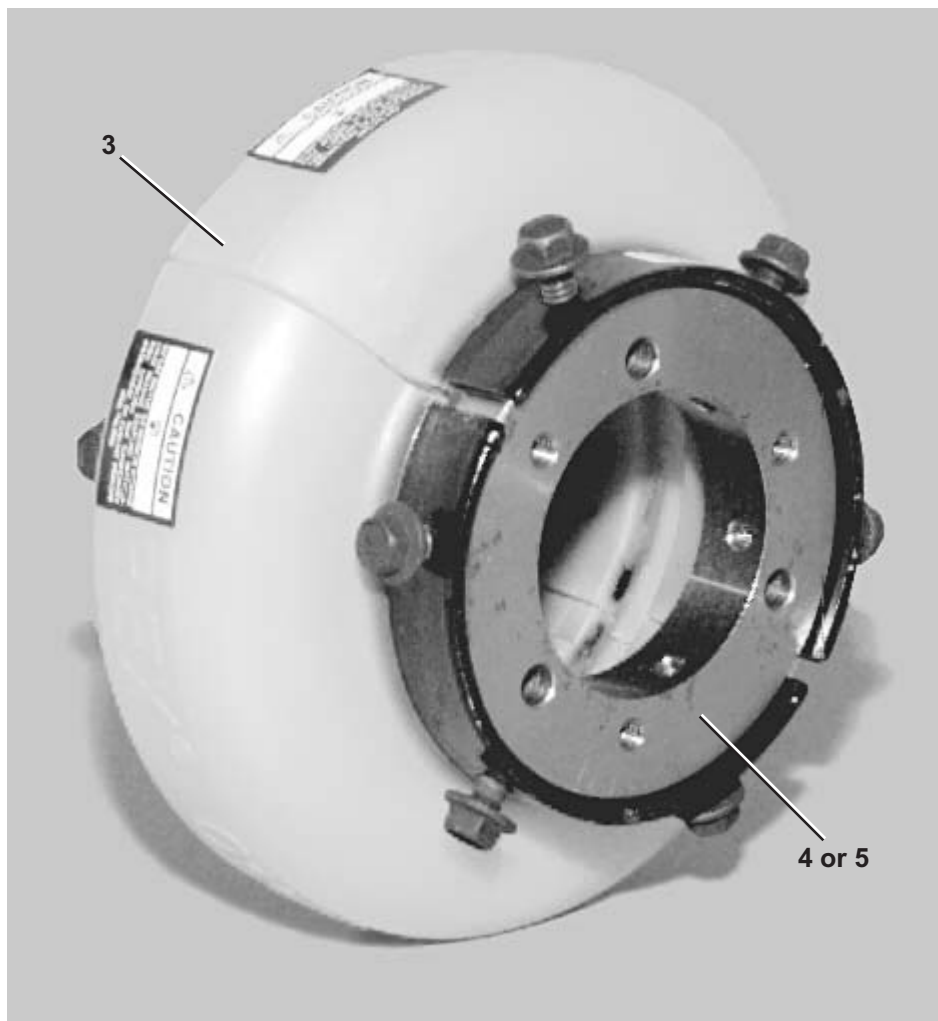



Pellerin Milnor Corporation
P. O. Box 400, Kenner, LA 70063-0400

Litho in U.S.A.

Parts List—Drive Connections

Find the correct assembly first, then find the needed components. The item letters (A, B, C, etc.) assigned to assemblies are referred to in the "Used In" column to identify which components belong to an assembly. The item numbers (1, 2, 3, etc.) assigned to components relate the parts list to the illustration.

Used In	Item	Part Number	Description	Comments
-----ASSEMBLIES-----				
	A	GDB63002	9248 DRIVE CONNECTION INSTALL	
-----COMPONENTS-----				
all	1	X6 30093	9248 DRIVE CNNCT SHAFT MACH	
all	2	06 20092D	WASHER DOUBLER ADJ. COUPLING	
all	3	54J227	FLEXCPLG REX#E10 (EA=2 HALVES)	
all	4	54J227A	HUB,FLEX COUPLING TUN +TILTS	
all	5	54J227B	HUB ADJ.COUPLING CBW	
all	6	56Q1CSDS	1+1/8" BUSH VPUL QD TYPE SDS	
all	7	56Q1ESDS	1+1/4" BUSH VPUL QD TYPE SDS	
all	8	15E210	SQMACHKEY 1/4X2 NOTAPER-NOHEAD	
all	9	15K095C	HXCAPSCR 3/8-16X1.25 GR.8 ZN.	
all	10	15U260	LOCKWASHER MEDIUM 3/8 SS18-8	

Support Roller Assembly
76028 & 76039 G3 Tunnels, 92048 G4 Tunnels

BMP000030/2011474B
 (Sheet 1 of 2)



Pellerin Milnor Corporation
 P. O. Box 400, Kenner, LA 70063-0400

Litho in U.S.A.

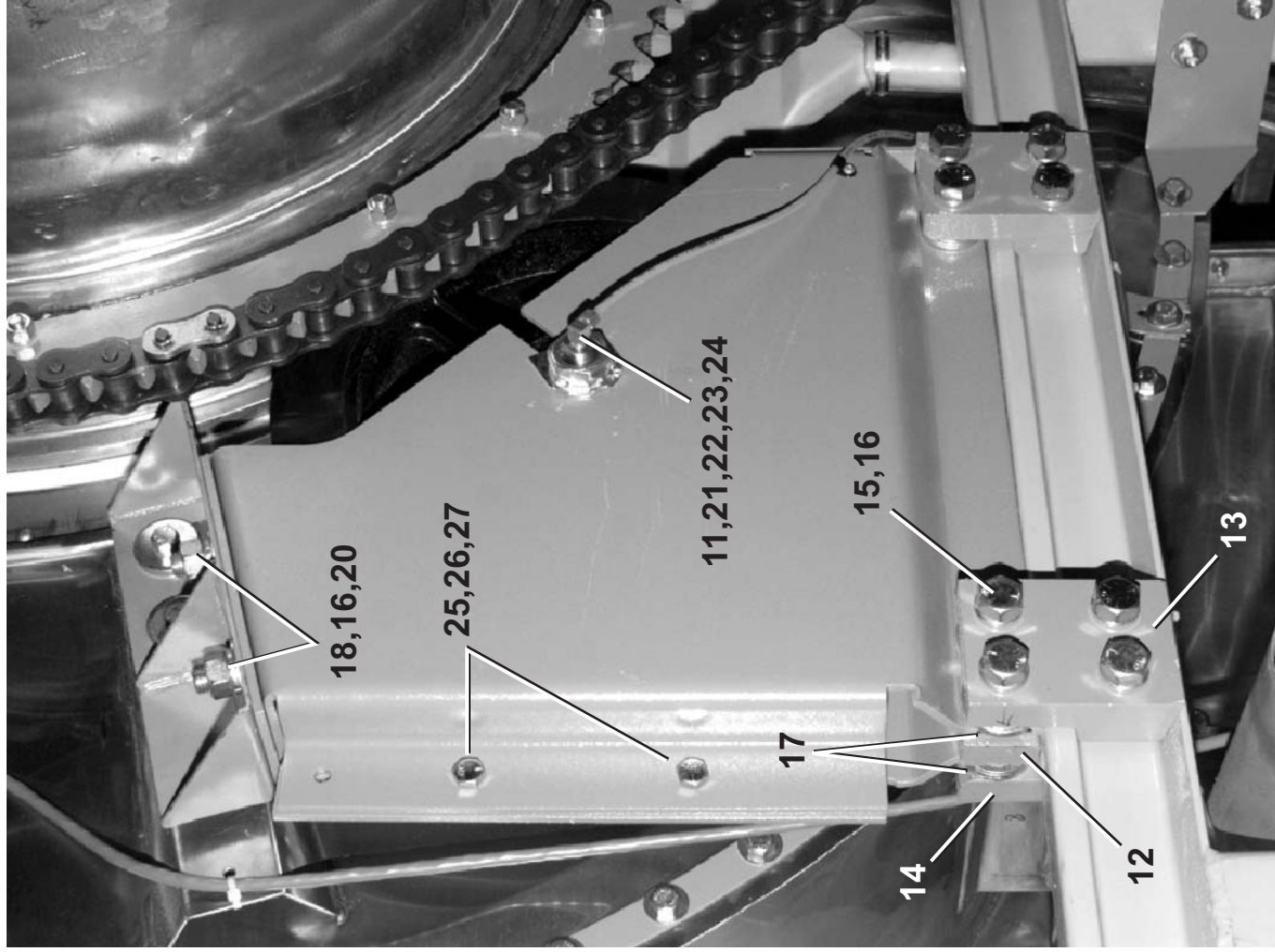

- * 1. Tighten nut (item 5) to 50 ft/lbs of torque. Do not use an impact wrench.
- 2. Grease each wheel assembly with 20H012A until completely packed.

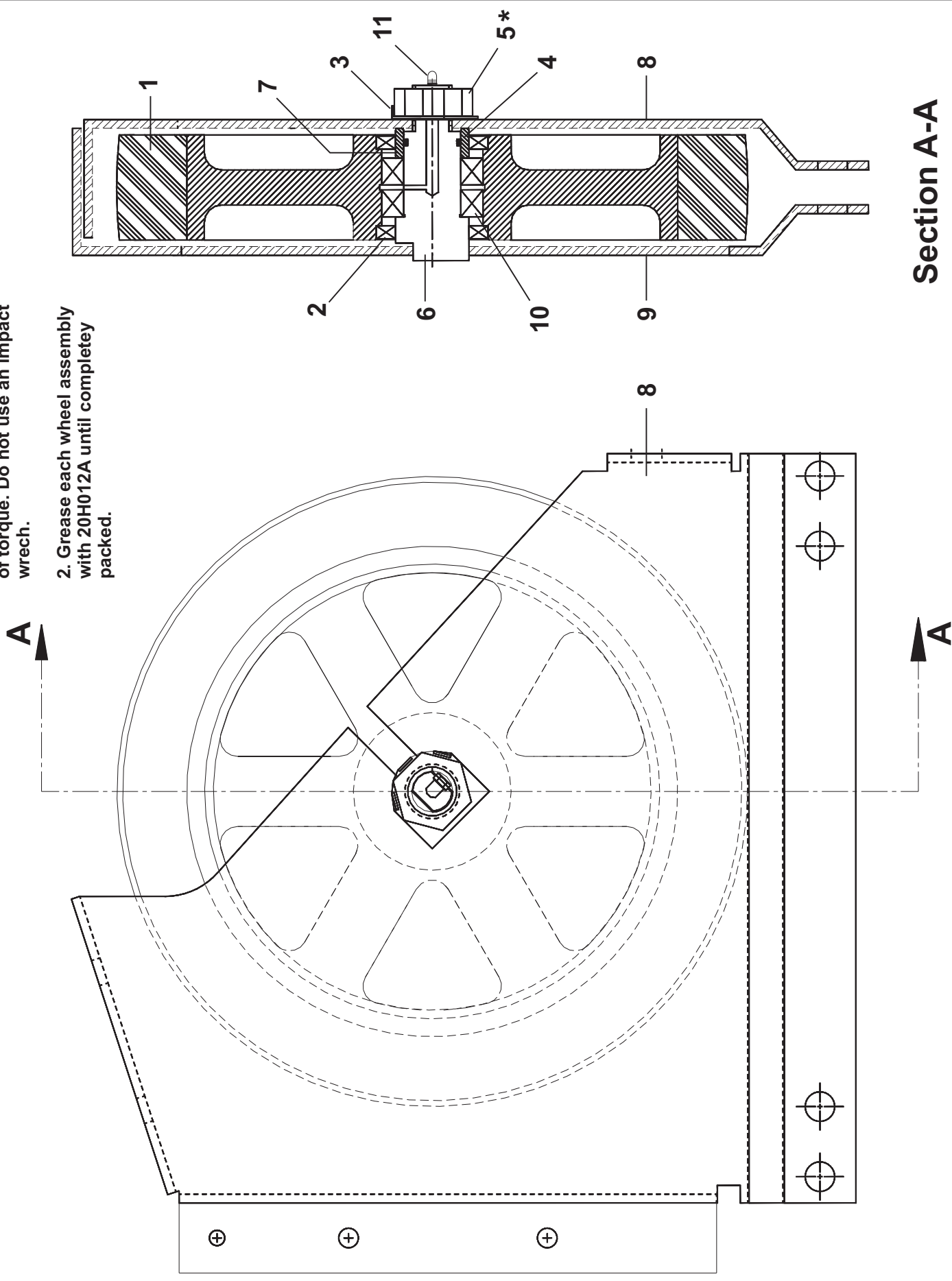

Section A-A



Pellerin Milnor Corporation
P. O. Box 400, Kenner, LA 70063-0400

Litho in U.S.A.

Parts List—Support Roller Assembly
Find the correct assembly first, then find the needed components. The item letters (A, B, C, etc.) assigned to assemblies are referred to in the "Used In" column to identify which components belong to an assembly. The item numbers (1, 2, 3, etc.) assigned to components relate the parts list to the illustration.

Used In		Item	Part Number	Description	Comments
-----ASSEMBLIES-----					
	A		A64SR002	SUPROLLER W/O TENSIONER-LF	7628G3, 7639G3
	B		A64SR002R	SUPROLLER W/O TENSIONER -RT	7628G3, 7639G3
	C		A64SR002AL	SUPROLLER W/TENSIONER FT LF	7628G3, 7639G3
	D		A64SR002BL	SUPROLLER W/TENSIONER REAR-LF	7628G3, 7639G3
	E		A63SR002	9248 SPPT RLLR ASSY LF	9248G4
	F		A63SR001	9248 SPPT RLLR ASSY RT	9248G4
-----COMPONENTS-----					
all	1		06 40040B	ROLLER 18X3 - 2" URETHANE	
all	2		24S055	SEAL 2.09X3.189X3/8 SS BUNA	
all	3		06 40043	LOCKING WASHER 18X3 ROLLER	
all	4		60C128	ORING 1+3/8IDX1/8CS BUNA70#220	
all	5		15G251	HEXJAMNUT 1+1/8-7UNC2 ZNC GR2	
all	6		X6 40041	MACH=SHAFT 18 X 3 ROLLER	
all	7		06 40042	COLLAR=18X3 ROLLER	
ABCD	8		06 70013G	PLATE WHEEL SUPPORT INNER LF	
ABCD	8		06 70013A	PLATE WHEEL SUPPORT INNER RT	
EF	8		06 30055	9248 SPPT RLLR BRKT INNER RT	
EF	8		06 30055A	9248 SPPT RLLR BRKT INNER LF	
ABCD	9		06 70013F	PLATE WHEEL SUPPORT OUTER LF	
ABCD	9		06 70013B	PLATE WHEEL SUPPORT OUTER RT	
EF	9		06 30054	9248 SPPT RLLR BRKT OUT RT	
EF	9		06 30054A	9248 SPPT RLLR BRKT OUT LF	
all	10		54AV41201	BRG TM#LM501349 ASSY 902B6 1BX	
all	11		53A031B	BODY-EL90MALE.25X1/8 #269C-42B	
all	12		06 70013H	SPACER=SUPPORT ROLLER	
all	13		06 70030	CLAMP SUPPORT ROLLER OUTER	
all	14		06 70030A	CLAMP SUPPORT ROLLER INNER	
all	15		15K235D	HXTAPSCR 3/4-10UNC2A X 4+1/2	
all	16		15U340	LOCKWASH MEDIUM 3/4 ZINCPL	
all	17		15U320P	FLATWASHER(USS STD) 3/4" ZNC P	
all	18		15K228B	HEXCAPSCR 3/4-10 X 1+1/2 GR 5/	
all	20		15G240	HXNUT 3/4-10UNC2B SAE ZINC GR2	
all	21		60E004TE	1/4"OD X.170"ID NYL(BLK)TUBING	

Parts List, cont.—Support Roller Assembly

Used In	Item	Part Number	Description	Comments
all	22	53A059A	NUT 1/4"BR.HOLYOKE AND #61A-4	
all	23	53A500	SLEEVE DELRIN 1/4"OD#60PT-4	
all	24	53A501	TUBE INSERT .163"OD #63PT-4-40	
all	25	15G230	HXNUT 1/2-13UNC2B SAE ZINC GR2	
all	26	15K151	HXCAPSCR 1/2-13UNC24X1.25 GR5	
all	27	15U300	LOKWASHER REGULAR 1/2 ZINC PLT	

Guide Roller Assembly
76028 & 76039 G3 Tunnels, 92048G4 Tunnels



Pellerin Milnor Corporation
 P. O. Box 400, Kenner, LA 70063-0400

BMP000031/2011474B
 (Sheet 1 of 2)

Litho in U.S.A.

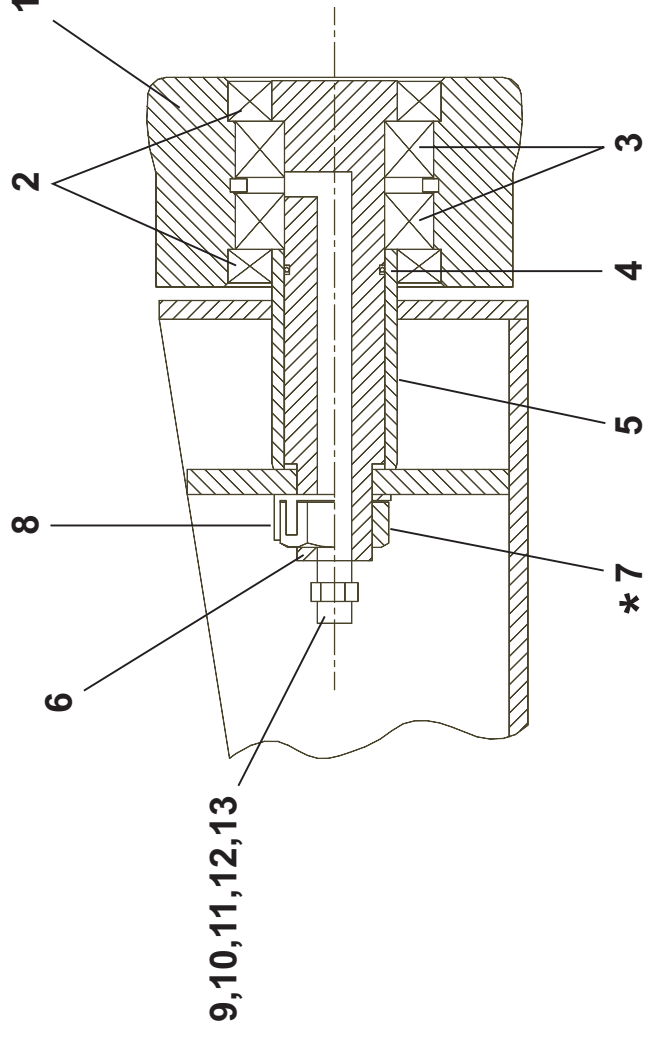
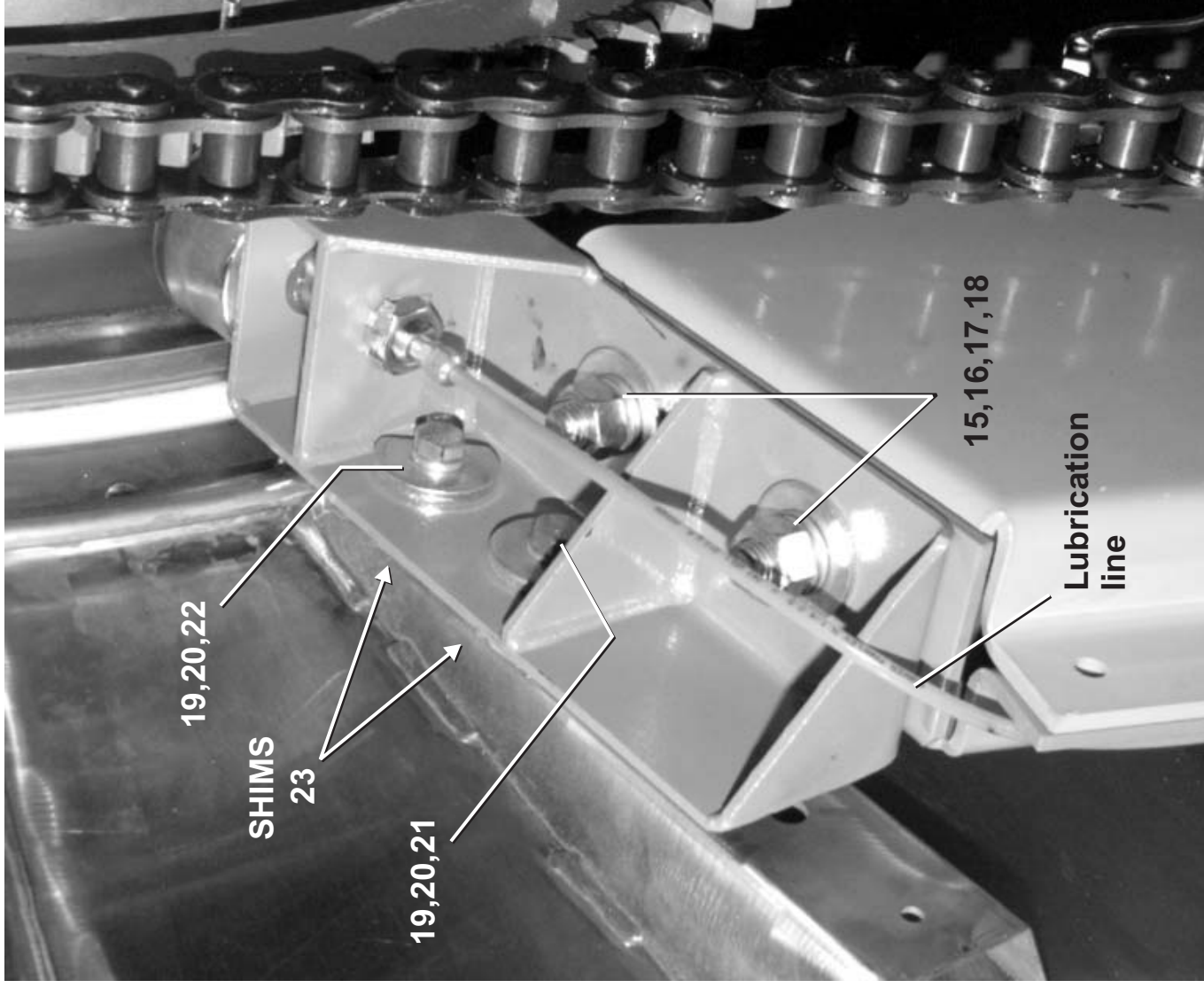

14
 * Torque nut (item 7) to 50 ft/lbs.

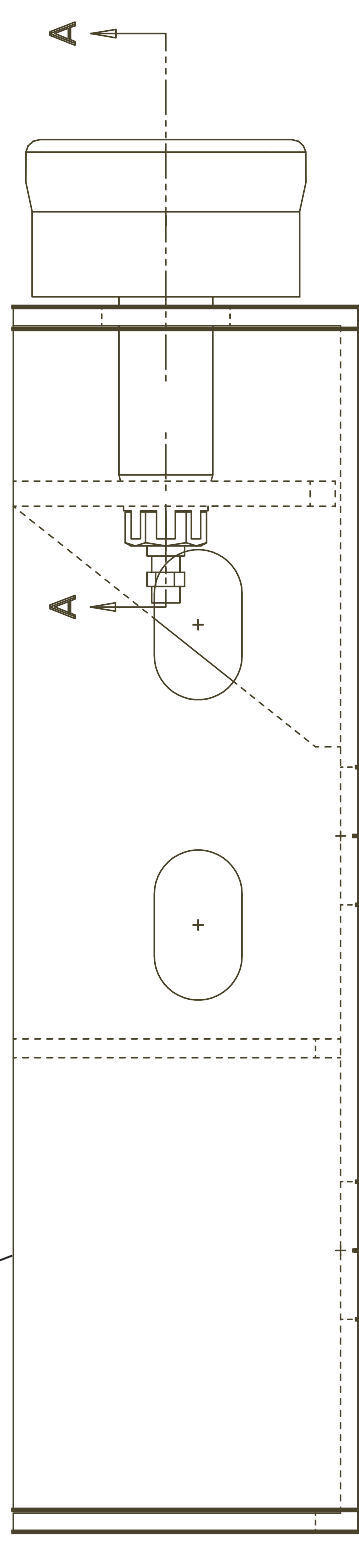



Pellerin Milnor Corporation
P. O. Box 400, Kenner, LA 70063-0400

Litho in U.S.A.

Parts List—Guide Roller Assembly

Find the correct assembly first, then find the needed components. The item letters (A, B, C, etc.) assigned to assemblies are referred to in the "Used In" column to identify which components belong to an assembly. The item numbers (1, 2, 3, etc.) assigned to components relate the parts list to the illustration.

Used In	Item	Part Number	Description	Comments
-----ASSEMBLIES-----				
	A	A64GR002	7639G3 GUIDE ROLLER ASSY RIGHT	7628/7639G3 RIGHT
	B	A64GR003	7639G3 GUIDE ROLLER ASSY LEFT	7628/7639G3 LEFT
	C	AGR63001	9248 GUIDE ROLLER RIGHT ASSY	9248G4 RIGHT
	D	AGR63001A	9248 GUIDE ROLLER LEFT ASSY	9248G4 LEFT
-----COMPONENTS-----				
all	1	06 40046	ROLLER=GUIDE 3.78 WIDE TRACK	
all	2	24S033A	SEAL 1.25X2.125X.375 JM# 19653	
all	3	54AV25401	BRG TIMK#L44643 ASSY 902A8 1BX	
all	4	60C120	ORING 7/8IDX1/16CS BUNA70 #020	
all	5	06 20068A	COLLAR=7622 CBW WHEEL SUPT	
all	6	06 20020B	SHAFT=7622 CBW GUIDE ROLLER	
all	7	15G245	HXFINJAMNUT 3/4-10UNC2 SS18-8	
all	8	06 20070	LOCKING WASHER ROLLER SHAFT	
all	9	53A031B	BODY-EL90MALE.25X1/8 #269C-42B	
all	10	53A059A	NUT 1/4"BR.HOLYOKE AND #61A-4	
all	11	53A500	SLEEVE DELRIN 1/4"OD#60PT-4	
all	12	53A501	TUBE INSERT .163"OD #63PT-4-40	
all	13	20H012	ALVANIA#71125/EPLF2 35# PAIL	
A	14	W6 70014G	WELD GUIDE ROLLER MNT MID RT	
B	14	W6 70014L	WELD GUIDE ROLLER MNT MID LF	
C	14	W6 30119	GUIDE RLLR SPPT BRKT RT WLMT	
D	14	W6 30119A	GUIDE RLLR SPPT BRKT LF WLMT	
all	15	15K232A	HEXCAPSCR 3/4-10X2 GR8 ZINC	
all	16	15U320P	FLATWASHER(USS STD) 3/4" ZNC P	
all	17	15U340	LOCKWASH MEDIUM 3/4 ZINCPL	
all	18	15G240	HXNUT 3/4-10UNC2B SAE ZINC GR2	
all	19	15K162	HXCAPSCR 1/2-13UNC2AX1.5 GR5 P	
all	20	15U286	FLATWASHER 2"ODX17/32"IDX1/4"	
all	21	15U300	LOKWASHER REGULAR 1/2 ZINC PLT	
all	22	02 11603A	WASHER DBLR=2" W/CUTOFF SIDE	
all	23A	06 20327A	SPACER 14 GA STN/STL	
all	23B	06 20327B	SPACER 16 GA STN/STL	
all	23C	06 20327C	SPACER 18 GA STN/STL	

Tension Seal Assembly
76028G2/G3 & 76039G2/G3 Tunnels, 92048G4 Tunnels

BMP840026/2011474B
 (Sheet 1 of 2)



Pellerin Milnor Corporation
 P. O. Box 400, Kenner, LA 70063-0400

Litho in U.S.A.

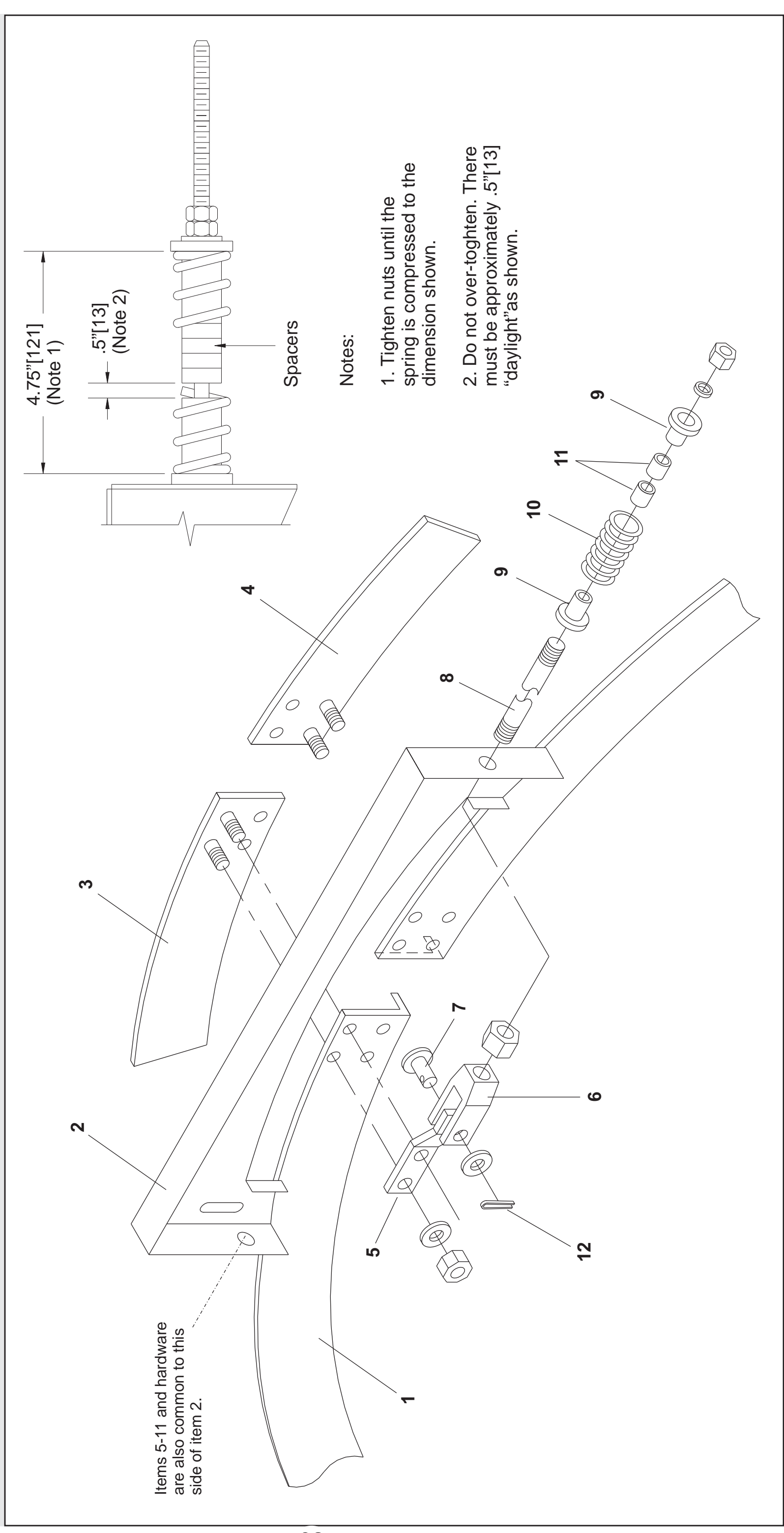



Pellerin Milnor Corporation
P. O. Box 400, Kenner, LA 70063-0400

Litho in U.S.A.

Parts List—Tension Seal Assembly

Find the correct assembly first, then find the needed components. The item letters (A, B, C, etc.) assigned to assemblies are referred to in the "Used In" column to identify which components belong to an assembly. The item numbers (1, 2, 3, etc.) assigned to components relate the parts list to the illustration.

Used In	Item	Part Number	Description	Comments
-----ASSEMBLIES-----				
	A	G62 00400H	INST SPLIT SEAL-ENTRY&EXIT	76028G2/G3 76039G2/G3
	B	GSS63001	SPLIT -LSEAL INSTALL	92048G4
-----COMPONENTS-----				
A	1	X6 20615	SEAL=OPEN CUT&DRILL	
B	1	X6 30038	SEAL OPEN,CUT&DRILL-8648CBW	
all	2	W6 20639	*L-SEAL CVR IN-LIP EXIT WLMT	
all	3	W6 20638	PLT=REINF-SPLT-SL-LG-LF-WLMT	
all	4	W6 20637	PLT=REINF-SPLT-SL-LG-RT-WLMT	
all	5	06 20416A	BRKT YOKE CONN.SPLIT SEAL	
all	6	17A004	ADJ YOKE END 1/4-28 XYLAN COAT	
all	7	17A004A	CLEVIS PIN 1/4"X3/4"DRILLED SS	
all	8	06 20416C	ROD=SPRING TENSION SPLITSEAL	
all	9	06 20416D	BUSHING=SPRING ALIGNMENT	
all	10	06 20162B	SPRING COMP.SPLIT SEAL TENS	
all	11	27B17006HN	SPCR .281ID.613OD.500L	
all	12	15H019	STDCOTTERPIN 1/16X1/2 SS18-8	

Shell & Cylinders

92048G4 Tunnels

BMP110069/2011475A
(1 / 2)



Pellerin Milnor Corporation
P. O. Box 400, Kenner, LA 70063-0400

Litho in U.S.A.

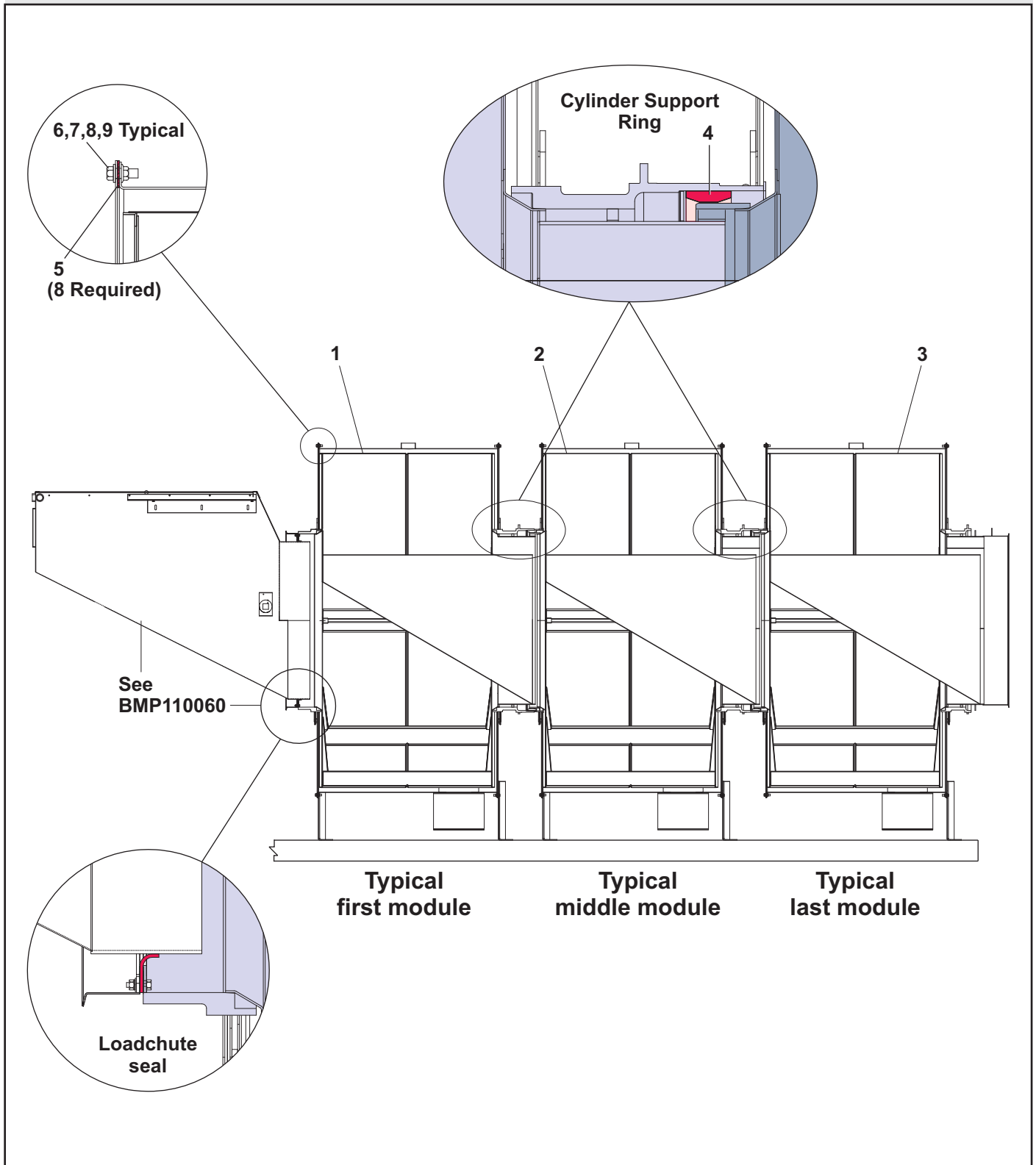



Pellerin Milnor Corporation
P. O. Box 400, Kenner, LA 70063-0400

Litho in U.S.A.

Parts List—Shell & Cylinders

Find the correct assembly first, then find the needed components. The item letters (A, B, C, etc.) assigned to assemblies are referred to in the "Used In" column to identify which components belong to an assembly. The item numbers (1, 2, 3, etc.) assigned to components relate the parts list to the illustration.

Used In	Item	Part Number	Description	Comments
-----ASSEMBLIES-----				
	A	ASE63001	9248 CYLSHLL END MOD 1 ASSY	
	B	ASE63002	9248 CYLSHLL END MID MOD ASSY	
	C	ASE63003	9248 CYLSHLL END LAST MOD ASSY	
-----COMPONENTS-----				
all	1	ACA63001	9248 FIRST MOD CYL WELDMENT	
all	2	ACA63001A	9248 MID MOD CYLINDER WLMT	
all	3	ACA63001B	9248 LAST MOD CYLINDER WLMT	
all	4	X6 30020	RING=BEARING CYL SPPT 9248	
all	5	06 30037	GASKET SEGMENT 9248 CBW	
all	6	15K153	HXCAPSCR 1/2 -13 X 1 +1/4 SS	
all	7	15U285	FLATWASHER 1/2 STD COMM SS18-8	
all	8	15G225H	HEXFLGNUT 1/2-13 SERRATED 18-8	
all	9	20C040B	SUPERFLEX CLR RTV SIL 10.2OZ	

Proximity Switch & Target Installation

92048G4 Tunnels

BMP110070/2011492B
(Sheet 1 of 3)

MILNOR
Pellerin Milnor Corporation
P. O. Box 400, Kenner, LA 70063-0400

Litho in U.S.A.

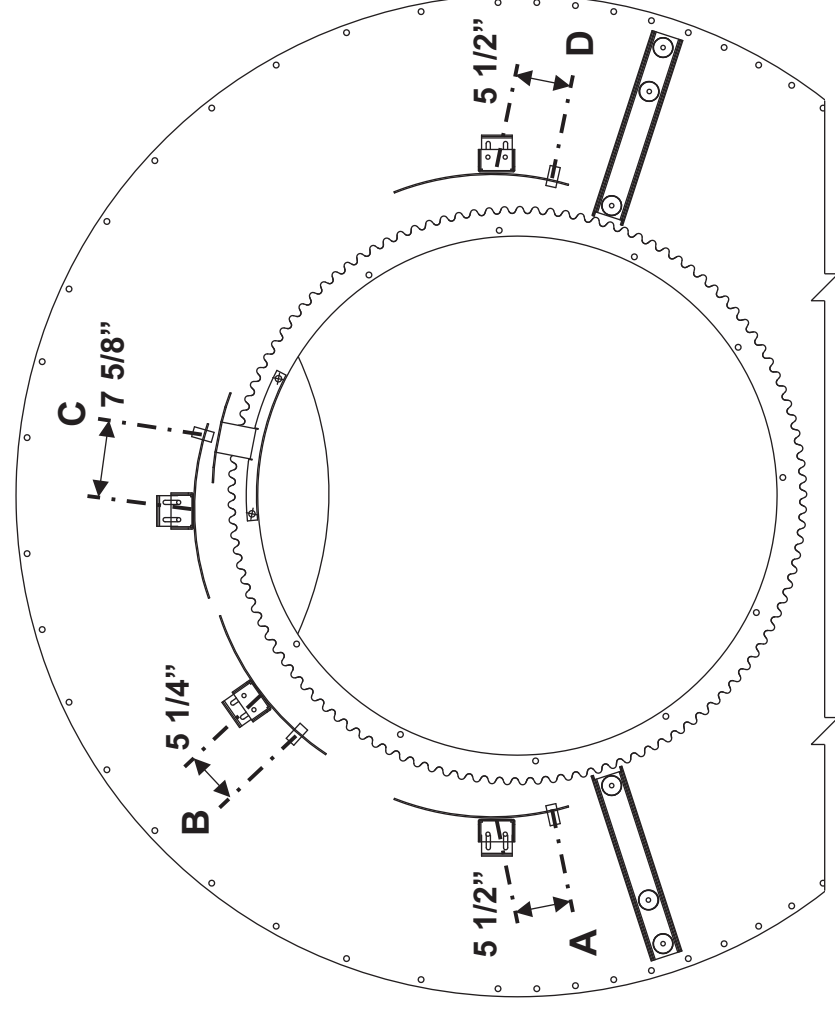

Discharge View - Exit Side of Shell

Proximity Switches:

All of the switch settings above reference the center line of their shell bracket. The shell bracket is welded to the shell. The holding bracket is bolted to the shell bracket and holds the proximity switch adjustment bracket.

- A) Clockwise Limit Switch is on exit shell of the first module.
- B) Safety Switch is on the exit shell of the second-to-last module.
- C) Top-Dead-Center Switch is on the exit shell of the second-to-last module.
- D) Counter Clockwise Limit Switch is on exit shell of the first module.

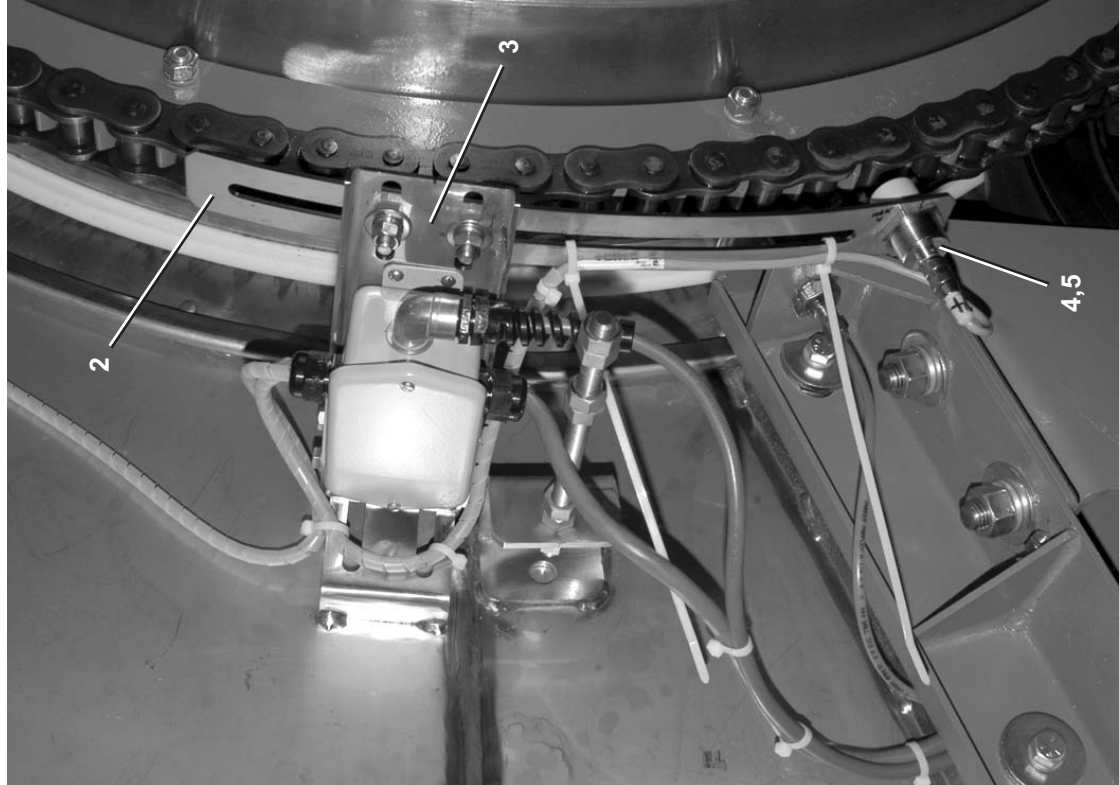

Clockwise Limit Switch (A)

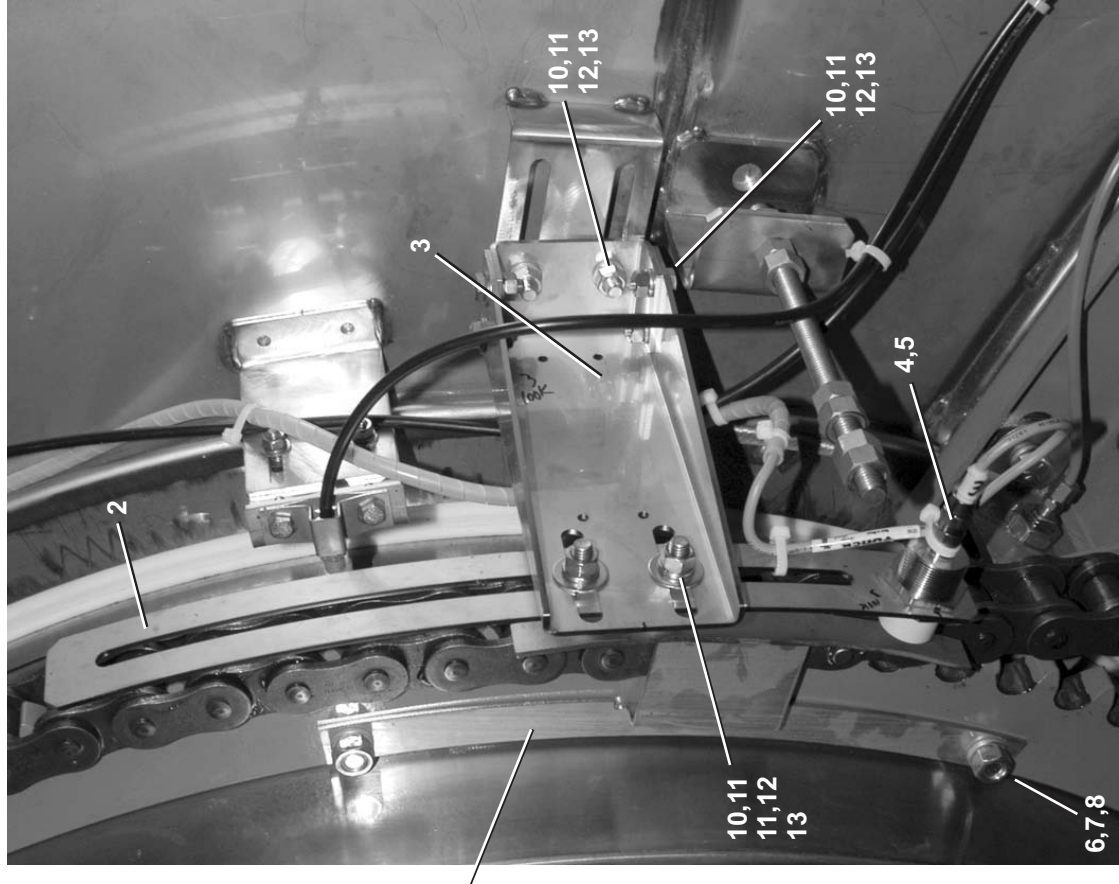

Counter Clockwise Limit Switch (D)

Proximity Switch & Target Installation
92048G4 Tunnels

BMP110070/2011492B
 (Sheet 1 of 3)



Pellerin Milnor Corporation
 P. O. Box 400, Kenner, LA 70063-0400

Litho in U.S.A.

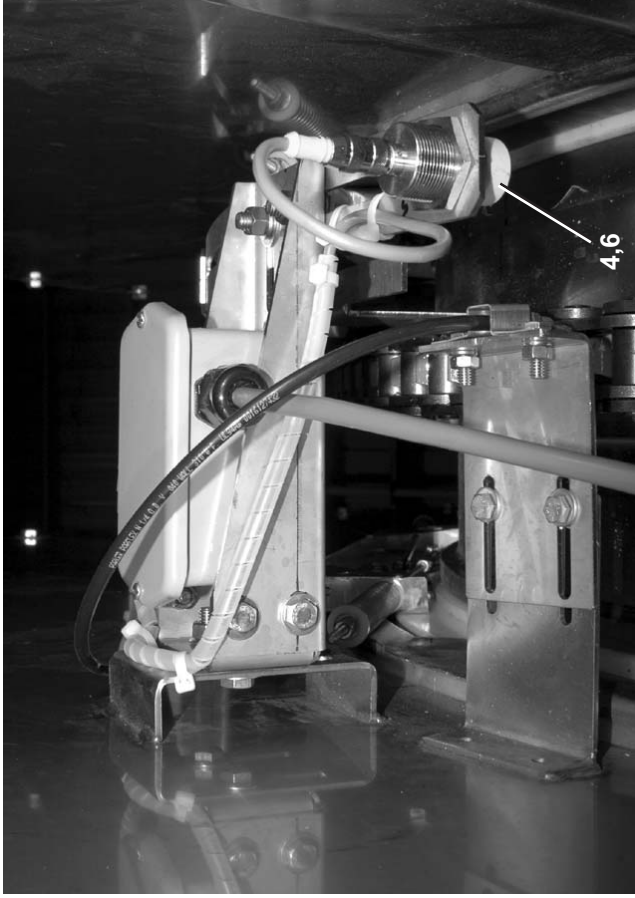

Safety Limit Switch
 (B)

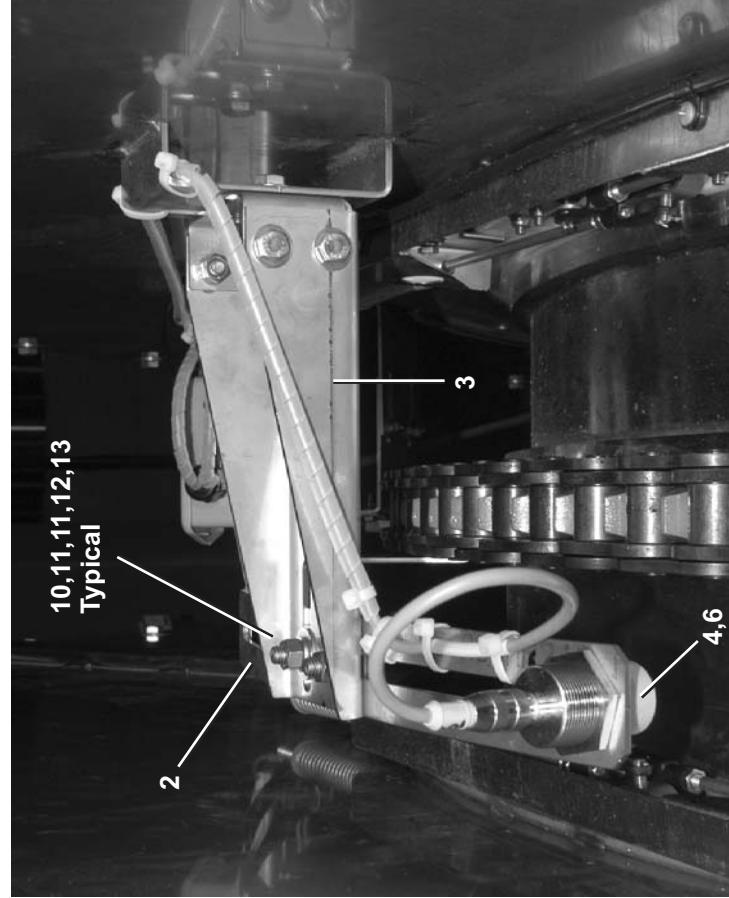

Top-Dead-Center
 Limit Switch (C)

Tunnel Rotation:

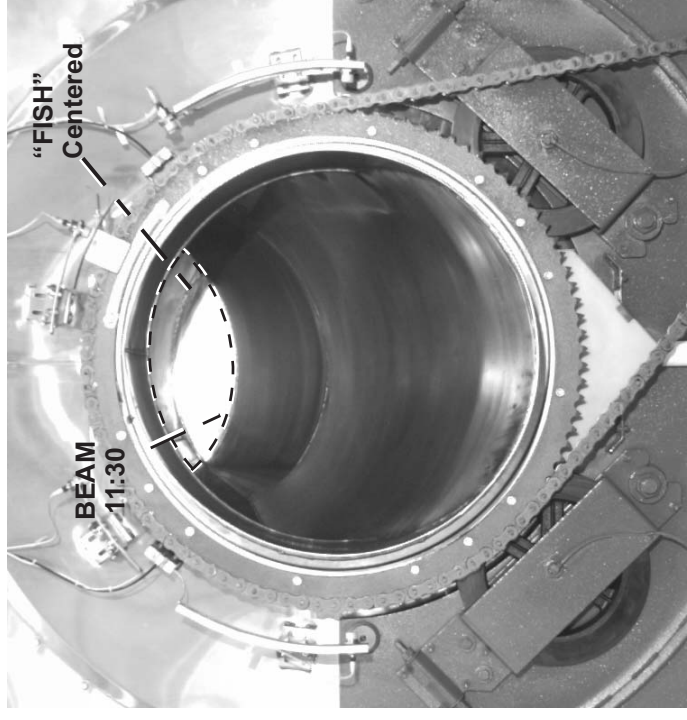

Top Dead Center

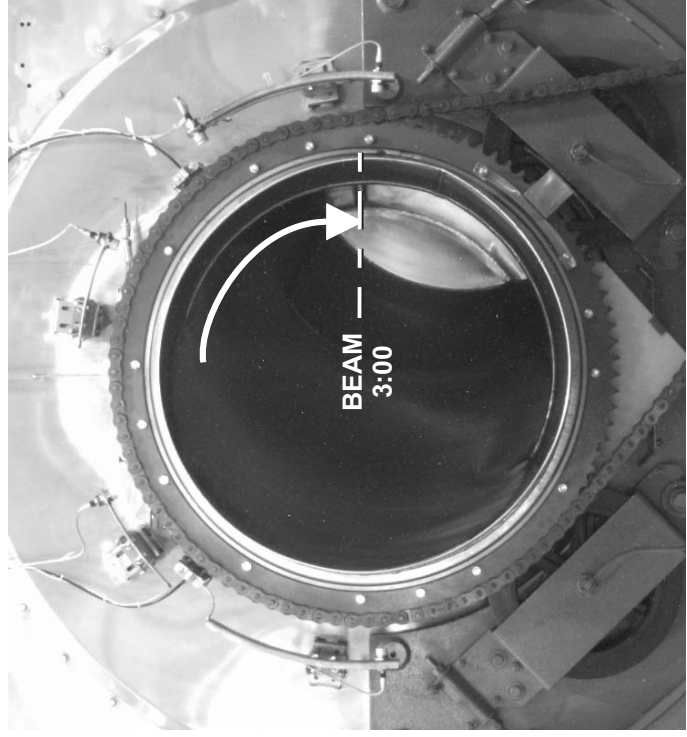

Maximum Counter-Clockwise Rotation
 (3:00 Position)

All positions are viewed from the rear (Discharge End).
 (Note: Photos are of the G2 welded tunnel, not the G4 tunnel.)

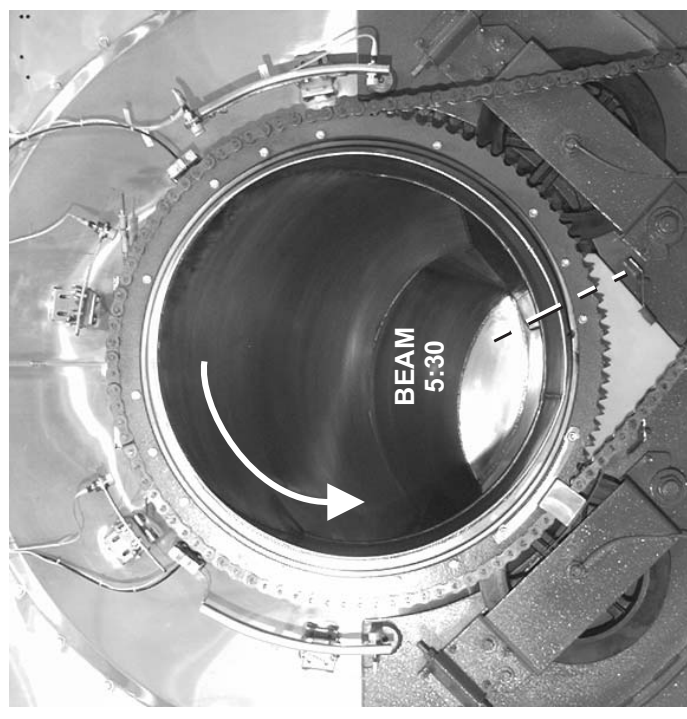

Maximum Clockwise Rotation
 (5:30 Position)



Pellerin Milnor Corporation
P. O. Box 400, Kenner, LA 70063-0400

Litho in U.S.A.

Parts List—Proximity Switch & Target Installation

Used In	Item	Part Number	Description	Comments
-----ASSEMBLIES-----				
	A	GPS63001	9248 CW/CCW PROX SWITCH INSTAL	
	B	GPS63002	9248 SAFTY/TDC PROX SWTCH INST	
-----COMPONENTS-----				
all	1	06 30092	9248 PROX SWITCH TARGET	
all	2	06 20644	PROX SW MTG RING-EXIT END	
all	3	06 40149	PROX SWITCH LATERAL ADJUSTER	
all	4	09RPS30ADU	PRXSW.QK CONN.30M NO-DC UNSHLD	
all	5	09RPSDC010	CONN.STR FEMALE DC 3A 300V 10M	
all	6	09RPSDC003	CONN.STR FEMALE DC 3A 300V 3M	
all	7	15K173A	HXCAPSCR 1/2-13UNC2AX1.75 GR5	
all	8	15U300	LOKWASHER REGULAR 1/2 ZINC PLT	
all	9	15G230	HXNUT 1/2-13UNC2B SAE ZINC GR2	
all	10	15K096	HEXCAPSCR 3/8-16UNC2X1SS18-8	
all	11	15U245	FLTWASH 3/8 STD COMM 18-8 SS	
all	12	15U255	LOCKWASHER MEDIUM 3/8 ZINCPL	
all	13	15G205	HXNUT 3/8-16UNC2B ZINC GR2	

Chain Oiler

76032, 76028G3 & 76039G3 Tunnels, 92048G4 Tunnels

BMP110071/2013102A
(1 / 2)



Pellerin Milnor Corporation
P. O. Box 400, Kenner, LA 70063-0400

Litho in U.S.A.

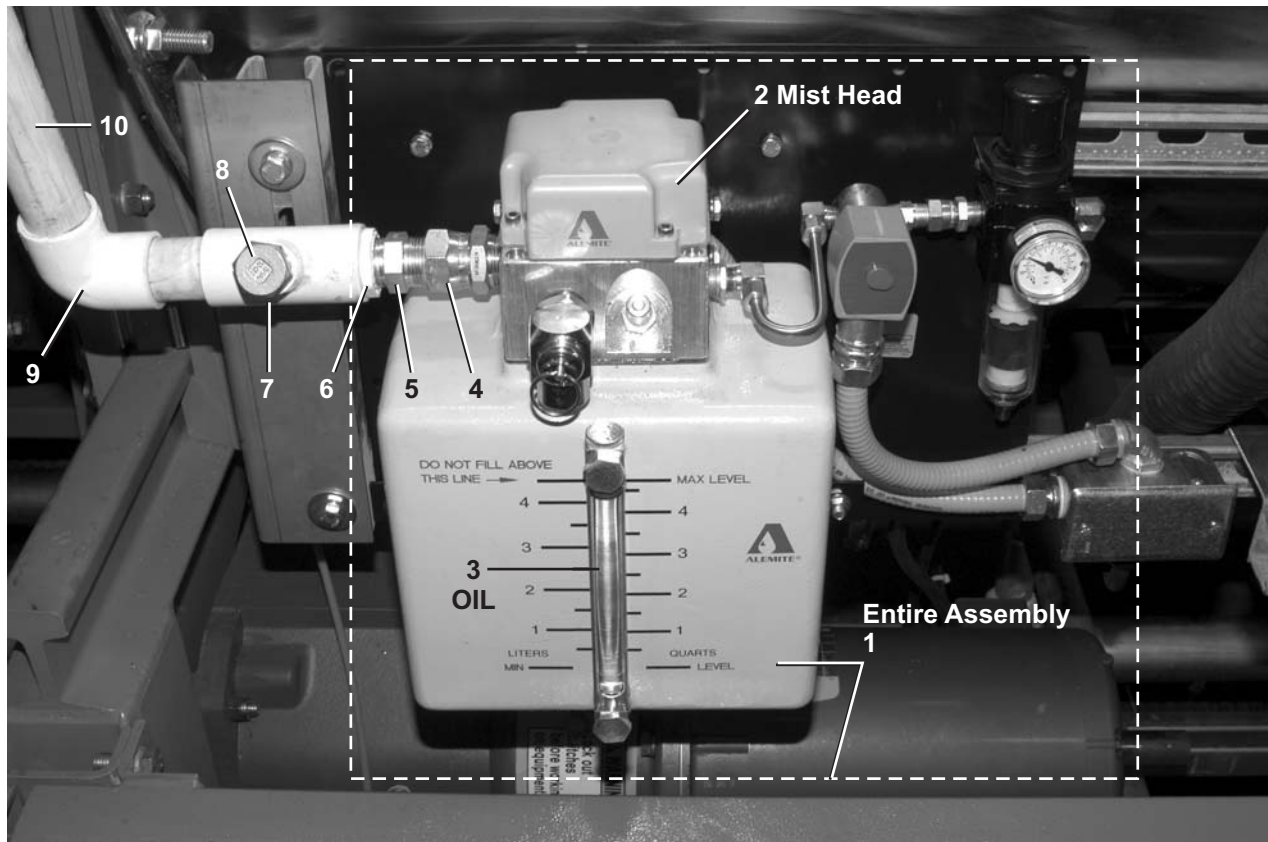
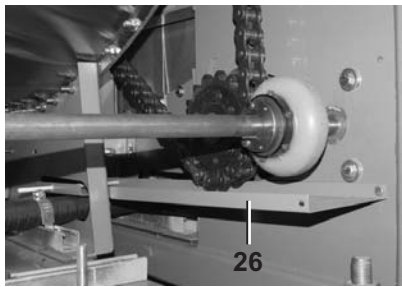
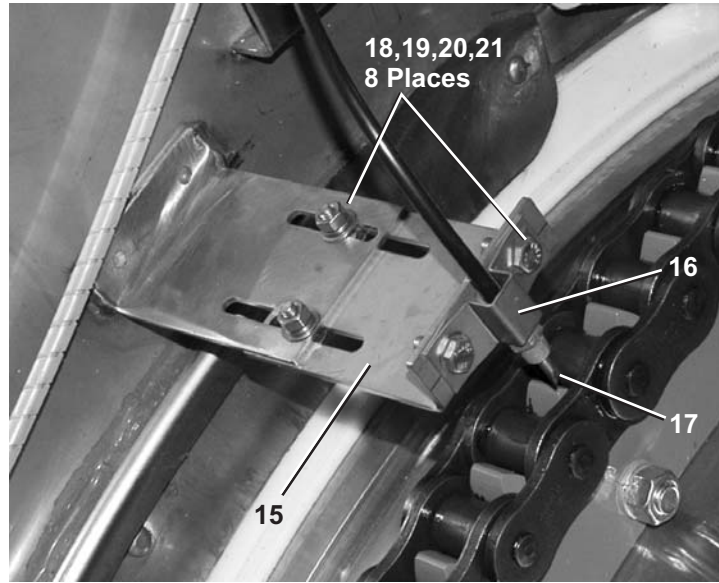
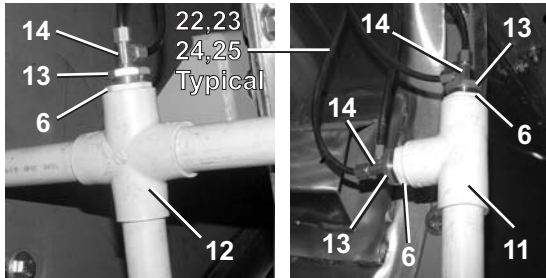



Pellerin Milnor Corporation
P. O. Box 400, Kenner, LA 70063-0400

Litho in U.S.A.

Parts List—Chain Oiler

Find the correct assembly first, then find the needed components. The item letters (A, B, C, etc.) assigned to assemblies are referred to in the "Used In" column to identify which components belong to an assembly. The item numbers (1, 2, 3, etc.) assigned to components relate the parts list to the illustration.

Used In	Item	Part Number	Description	Comments
-----ASSEMBLIES-----				
	A	G67CL001	GEN ASSY OILER RESV G3	76028G3, 76039G3 & 92048G4 TUNNELS 76032 TUNNELS
	B	A67CL001	ASSY OILERRESV G3	
	C			
-----COMPONENTS-----				
ABC	1	27E790E	ALEMITE OILMIST SYSTEM#3943BC	
ABC	2	27E790F	REPAIR PART-ALEMITE MIST HEAD	
all	3	20H000A	MILNOR CHAIN LUBRICANT	
all	4	52ZC0PS004	TUBEFITMALESW 3/4"#1404-12-12	
all	5	52ZC0PS003	TUBEFITMALECON 3/4"#2404-12-12	
all	6	5KC1AP4D0P	SOKADAPTER 1"SX3/4"FP PVC S40	
all	7	5K1AP4A0K	TEE 1"SX1"SX1/2"FP PVC S40	
all	8	5SP0KDEHK	NPT PLUG 1/2 HXCTRSNK GALSTL	
all	9	5KL1AP4A	SOK ELBOW 90DEG 1" PVC SCH40	
all	10	5P1AP4EN	1" PIPE PVC SK40 20RML	
all	11	5K1AP8A	SOKTEE 1" PVC SCH40	
all	12	5KX1AP4	SOK CROSS 1" PVC SK40	
all	13	5SB0P0CNFA	NPTHEXBUSH 3/4X1/8GALV150#CORD	
all	14	53A043S	TEE=TUBEXMPXTUBE 1/4"#B71A-4B	
all	15	06 40199	7626 BRKT OILER BRUSH	
all	16	06 20187	BRKT BRUSH HOLDER OILER 1/MD	
all	17	27E790D	SPRAYFITT=ALEMITE #381288-8	
all	18	15K039	HXCAPSCR 1/4-20UNC2AX3/4 GR5 Z	
all	19	15G165	HXNUT 1/4-20UNC2BSAE ZC GR2	
all	20	15U180	LOCKWASHER MEDIUM 1/4 ZINCPL	
all	21	15U185	FLATWASHER(USS STD) 1/4" ZNC P	
all	22	53A509	TUBE INSERT 5/16"OD X .53"LG.	
all	23	53A059	SLEEVE 1/4"BRASS PH#60C-4	
all	24	53A059A	NUT 1/4"BR.HOLYOKE AND #61A-4	
all	25	60E004TE	1/4"OD X.170"ID NYL(BLK)TUBING	

2

Load Chute and Seals

2.2

Load Chute and Seal Installation
76028G3, 76039G3, & 92048G4 Tunnels

BMP110060/2011483B
 (Sheet 1 of 4)



Pellerin Milnor Corporation
 P. O. Box 400, Kenner, LA 70063-0400

Litho in U.S.A.

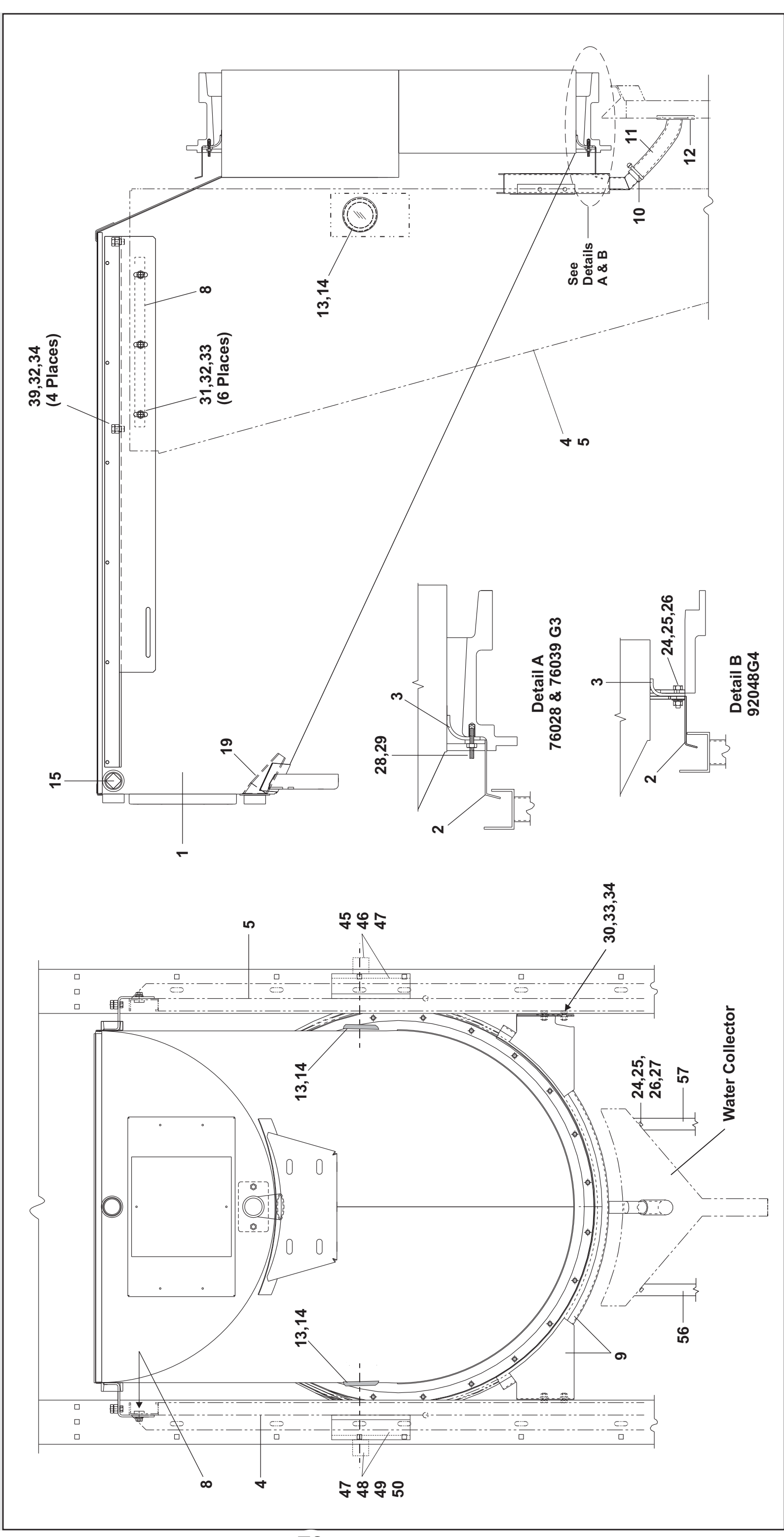

Load Chute and Seal Installation

76028G3, 76039G3, & 92048G4 Tunnels

BMP110060/2011483B
(Sheet 2 of 4)



Pellerin Milnor Corporation
P. O. Box 400, Kenner, LA 70063-0400

Litho in U.S.A.

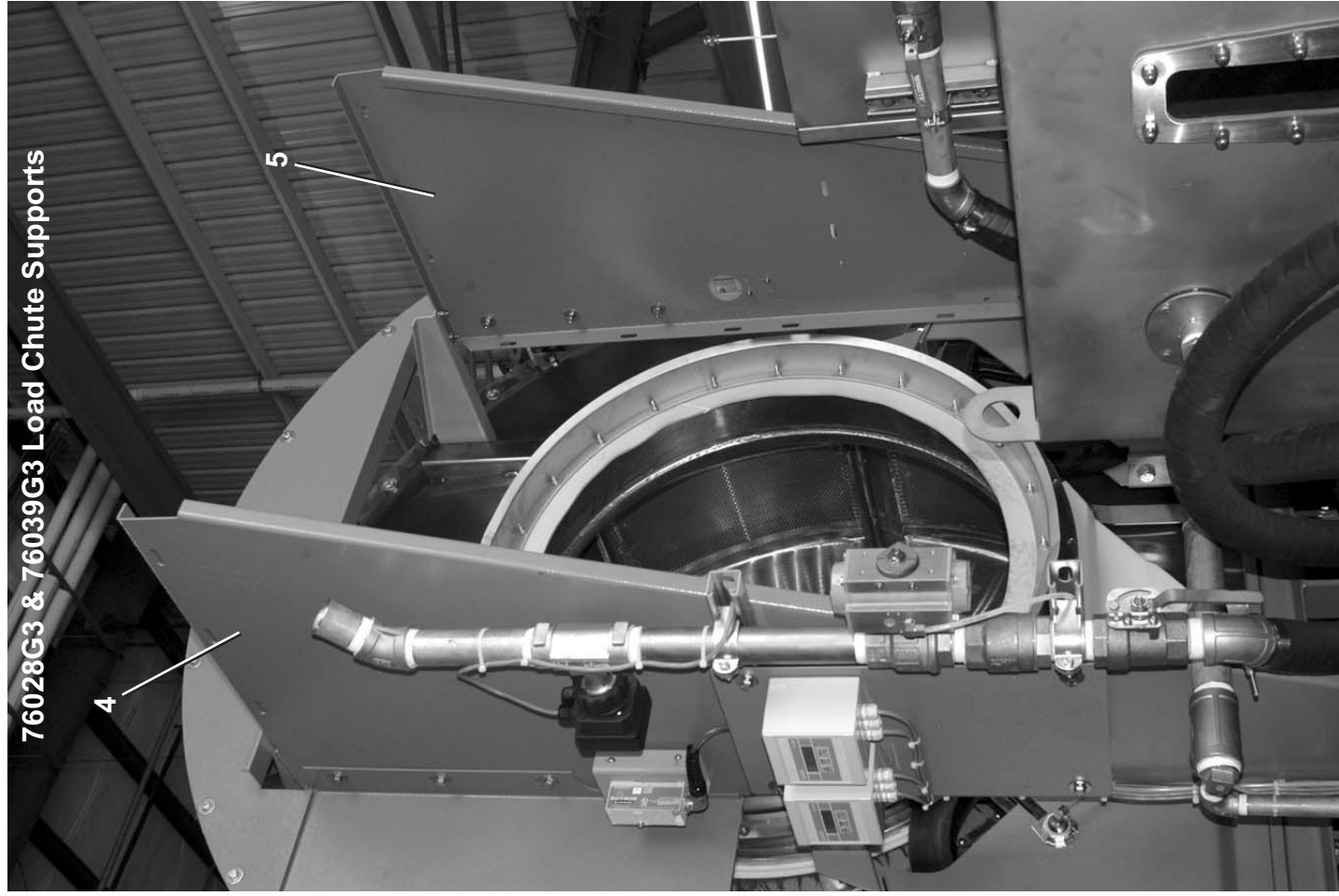

76028G3 & 76039G3 Load Chute Supports

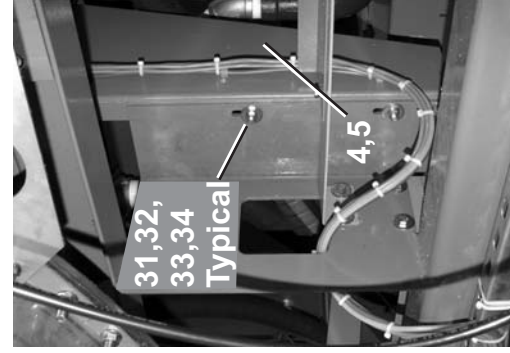
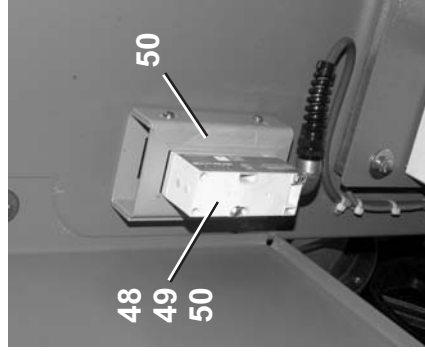
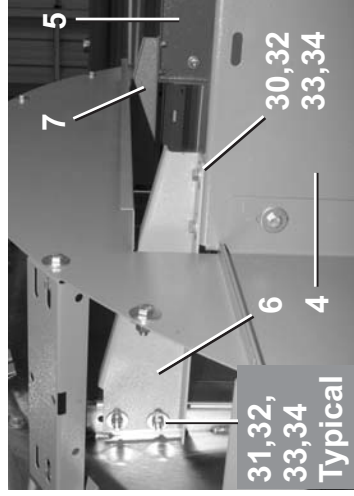

Typical Hardware Connections

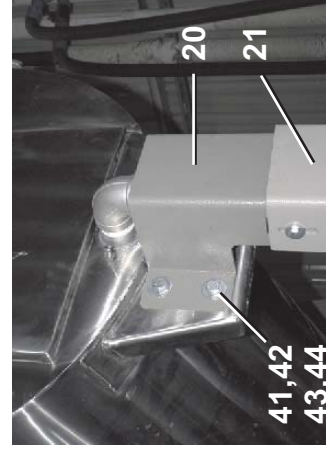

Load Chute and Seal Installation

76028G3, 76039G3, & 92048G4 Tunnels

BMP110060/2011483B
(Sheet 3 of 4)



Pellerin Milnor Corporation
P. O. Box 400, Kenner, LA 70063-0400

Litho in U.S.A.

Parts List—Load Chute and Seal Installation
Find the correct assembly first, then find the needed components. The item letters (A, B, C, etc.) assigned to assemblies are referred to in the "Used In" column to identify which components belong to an assembly. The item numbers (1, 2, 3, etc.) assigned to components relate the parts list to the illustration.

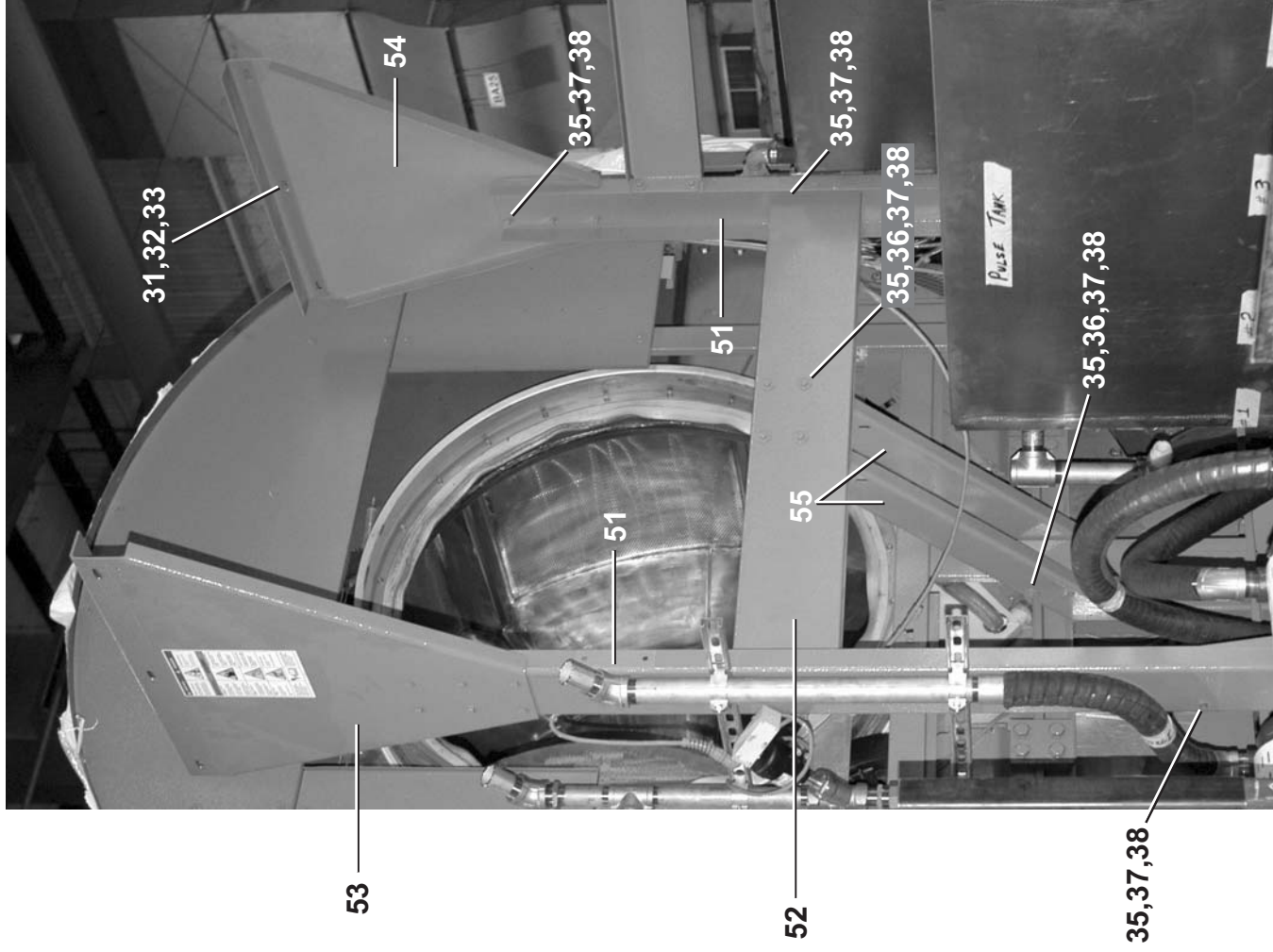

92048G4 Tunnel Load Chute Supports

Used In	Item	Part Number	Description	Comments
-----ASSEMBLIES-----				
	A	G65GC002	LG-LD SCOOP/SEAL INSTALL=Y2KCB	76028G3, 76039G3
	B	GLC63001A	9248 W/PULSEFLOW LOAD CHUTE INSTALL	92048G4
-----COMPONENTS-----				
A	1	W6 20731B	BAG LOAD CHUTE WLMT	
B	1	W6 30071B	9248 W/PULSEFLOW LOAD CHUTE WLMT	
A	2	W6 20732	*LG CHUTE FLARE-RING WLMT	
B	2	06 30112	9248 LOAD CHUTE FLARE RING	
A	3	06 20212U	LG CBW-LOAD CHUTE SEAL	
B	3	06 30088	LOAD CHUTE SEAL	
A	4	06 40132C	LOAD COS SCOOP SIDE LF G3	
A	5	06 40132D	LOAD COS SCOOP SIDE RT G3	
A	6	06 40132G	BRKT=LOAD SCOOP SUPPORT-LFT	
A	7	06 40132H	BRKT=LOAD SCOOP SUPPORT-RGT	
A	8	06 20316	TAP BAR LOAD FUNNEL 2/TUNNEL	
B	8	06 30089	LOAD CHUTE SUPT TAP BAR	
A	9	W6 40117E	G3 H20 CATCHER/CHAIN PROT WLT	
B	9	W6 30145	LOAD CHUTE H20 CATCHER WLMT	
all	10	27A060	HOSECLAMP1+5/16-2.25CADSC#HS28	
all	11	60E014R	TUBING NYLOBRAID 1.25X1.75	
all	12	60E010	TUBINGPOLYBRAID 1"X1.312	
all	13	06 20739	EXTRUSION GLASS PROXSW	
all	14	06 20739A	GLASS=3.06 DIA PROXSW	
all	15	5SP1EDESC	NPT PLUG 1.25 SQCORDED GALV CI	
all	16	5N1ECLSG42	NPT NIP 1.25XCLS TBE GALSTLS40	
A	17	5SL1ENFA	NPT ELB 90DEG 1.25 GALMAL 150#	
B	17	5SL1KNFA1E	NPT ELB 90D 1.5X1.25GALMAL 150#	
all	18	5N1E02KG41	NPT NIP 1.25X2.5 TOE GALSTL S4	
all	19	W6 70262	CBW LOAD CHUTE FLUSH PIPE	
A	20	06 70247	7639 PULSEFLOW CHUTE SUPPORT	
B	20	06 70249	9248 CHUTE SUPPORT W/PULSEFLOW	
A	21	06 70246	G3 LOADCHUTE SUPPORT BRKT	
B	21	06 70255	LOADCHUTE SUPPORT BRKT	



Pellerin Milnor Corporation
P. O. Box 400, Kenner, LA 70063-0400

Litho in U.S.A.

Used In		Item	Part Number	Description	Comments
all		22	06 20737	FLUSH COVER PLATE	
all		23	15N186	HXCAPSCR 1/4-20X3/4 SS18-8	
all		24	15U181	LOCKWASHER MEDIUM 1/4 SS18-8	
all		25	15U188	FLTWASH 1/4 STD COMM SS18-8	
all		26	15G170	HEXNUT 1/4-20UNC2 SS18-8	
all		27	15K033	BUTSOKCAPSCR 1/4-20X5/8 SS18-8	
all		28	15Q041	SOKSETSCR 5/16-18X1+3/4 SS18-8	
all		29	15G188	HEXLOKNUT 5/16-18 BRASS	
all		30	15K096	HEXCAPSCR 3/8-16UNC2X1SS18-8	
all		31	15K100	HEXCAPSCR 3/8-16X1+1/4 SS18-8	
all		32	15U245A	FLTWASH 25/64IDX1.25ODX3/32 S/	
all		33	15U260	LOCKWASHER MEDIUM 3/8 SS18-8	
all		34	15G206	HEXNUT 3/8-16 UNC2 SS 18-8	
all		35	15K105	HXCAPSCR 3/8-16UNC2A1.25 GR5 P	
all		36	15U240	FLATWASHER(USS STD) 3/8" ZNC P	
all		37	15U255	LOCKWASHER MEDIUM 3/8 ZINCPL	
all		38	15G205	HXNUT 3/8-16UNC2B ZINC GR2	
all		39	15K122A	HEXCAPSCREW 3/8-16X2.25 SS FT	
all		41	15K162	HXCAPSCR 1/2-13UNC2AX1.5 GR5 P	
all		42	15U280	FL+WASHER(USS STD)1/2 ZNC PL+D	
all		43	15U300	LOKWASHER REGULAR 1/2 ZINC PLT	
all		44	15G230	HXNUT 1/2-13UNC2B SAE ZINC GR2	
all		45	09RPE006A	PHOTOEYE EMITTER 24/120V AC	
all		46	09RPE007A	P.E. PWR.BLK. NO-OUT 120V-IN	
all		47	03 BC6X66	BRKT: CBW PHOTOEYE-LOAD SCP	
all		48	09RPE006B	PHOTOEYE RECEIVER 24/120V AC	
all		49	09RPE007B1	P.E. PWR.BLK. 120V-OUT 120V-IN	
all		50	09RPE006B2	PHOTOEYE ON/OFF LOGICMOD #LM3	
B		51	06 30079	LOAD CHUTE VERTICAL MOUNT	
B		52	06 30081	LD CHUTE HORZ BRACE	
B		53	06 30090	LD CHUTE TOP MOUNT BRKT LF	

Parts List, cont.—Load Chute and Seal Installation

Used In	Item	Part Number	Description	Comments
B	54	06 30090A	LD CHUTE TOP MNT BRKT RT	
B	55	06 30169	LOAD CHUTE ANGLE SPPT BRKT	

Water Collectors
76028G3, 76039G3, & 92048G4

BMP000035/2011444B
 (Sheet 1 of 2)



Pellerin Milnor Corporation
 P. O. Box 400, Kenner, LA 70063-0400

Litho in U.S.A.

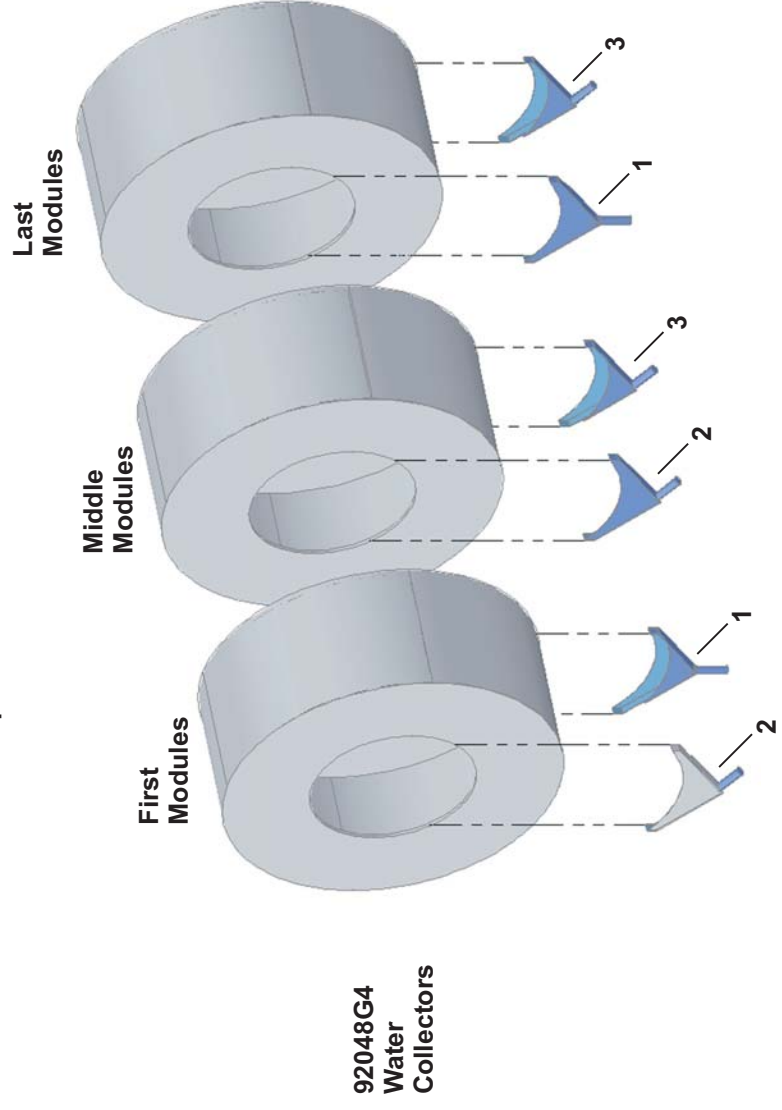
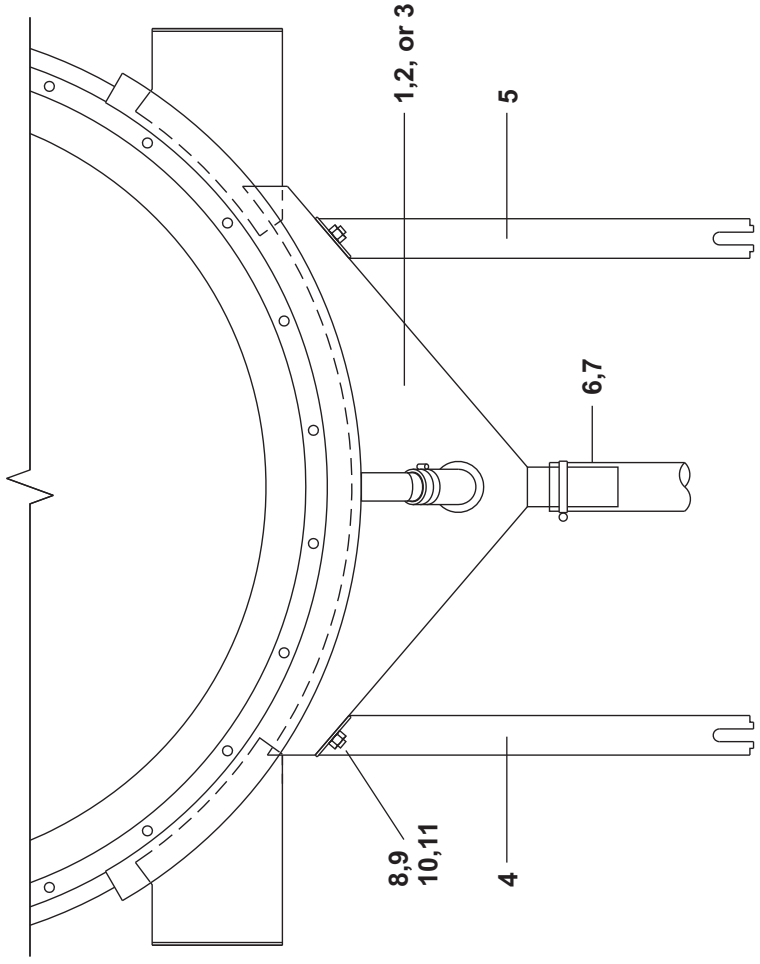
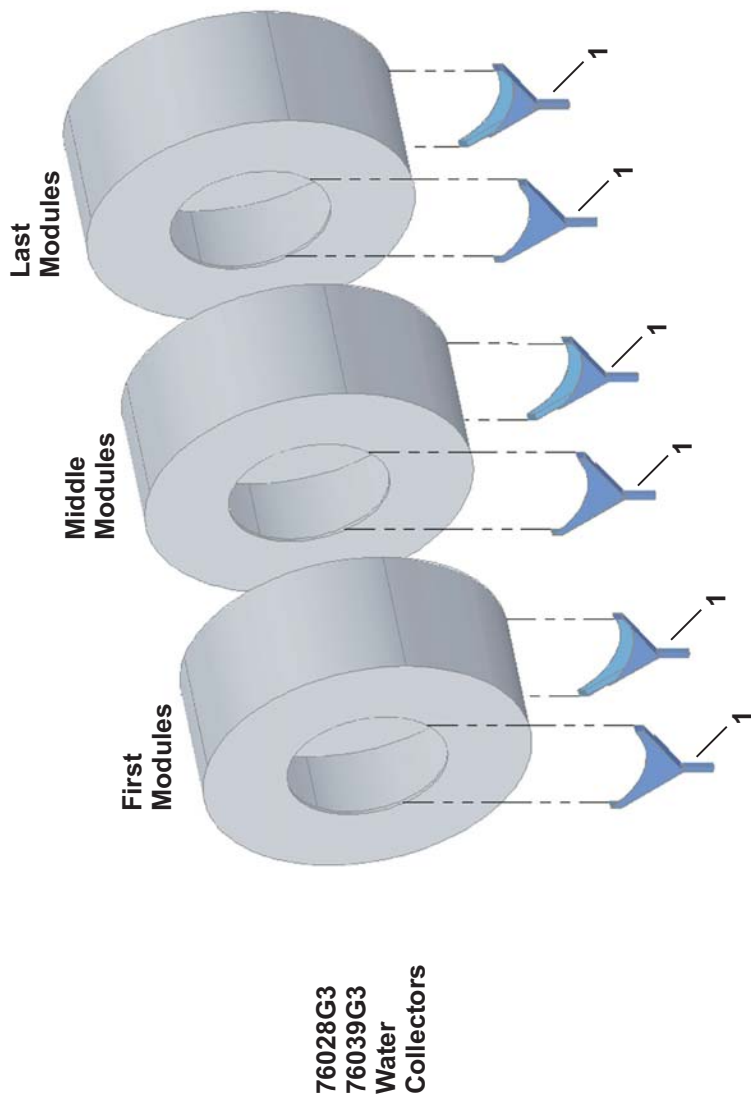
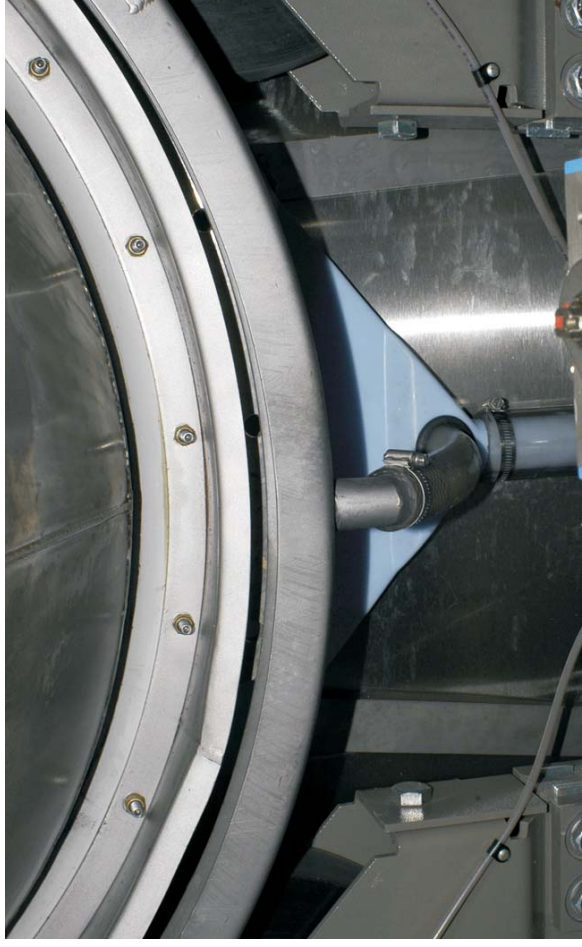



Pellerin Milnor Corporation
P. O. Box 400, Kenner, LA 70063-0400

Litho in U.S.A.

Parts List—Water Collectors

Find the correct assembly first, then find the needed components. The item letters (A, B, C, etc.) assigned to assemblies are referred to in the "Used In" column to identify which components belong to an assembly. The item numbers (1, 2, 3, etc.) assigned to components relate the parts list to the illustration.

Used In	Item	Part Number	Description	Comments
-----ASSEMBLIES-----				
	A	G67WC001	G3 WATER COLLECTOR ASSY	76028G3, 76039G3 92048G4
	B	G63WC003	9248 LOAD CHUTE H2O CATCH INST	92048G4
	C	G63WC002A	WATER CATCHER ANGLE OUT RT INS	92048G4
	D	G63WC002	WATER CATCHER ANGLE OUT INST	92048G4
-----COMPONENTS-----				
all	1	06 20629D	ENTRY&EXIT H2O COLLECT-TARG	SEE ILLUSTRATION
all	2	06 20629C	INLET WATER COLLECT NO-TARG	SEE ILLUSTRATION
all	3	06 20629B	EXIT SIDE-WATER COLL NO-TARG	SEE ILLUSTRATION
AB	4	06 20632B	SCUPPER BRKT LEFT SIDE	G3
AB	4	06 20232D	SCUPPER BRKT LEFT 9248	G4
AB	5	06 20632A	SCUPPER BRKT RIGHT SIDE	G3
AB	5	06 20232C	SCUPPER BRKT RIGHT 9248	G4
all	6	60E016B	CLEAR TUBING 1.75"ID X 2.25"OD	
all	7	27A065S	HOSECLAMP 1.56"-2.5"SSSCR#32	
all	8	15K033	BUTSOKCAPSCR 1/4-20X5/8 SS18-8	
all	9	15U188	FLTWASH 1/4 STD COMM SS18-8	
all	10	15U181	LOCKWASHER MEDIUM 1/4 SS18-8	
all	11	15G170	HEXNUT 1/4-20UNC2 SS18-8	

2

Water, Steam and Peristaltic

2.3

PulseFlow® Water Options: Schematic and Piping

76028, 76039, 92048 Pulse Flow Tunnels

Schematic (See parts list page 12.)

Water Valves and Pumps in PulseFlow® Options

ALTERNATE PulseFlow®: For goods incompatibility, creates 2 separate water streams with separate zones, and an empty module (boundary) between goods change. A continuous drain to sewer during PulseFlow® counterflow purges empty module between incompatible goods. Switching valves direct hot, cold or tempered water to the modules depending on whether used as refill after drain or used during the PulseFlow® sequence.

Note: Fresh water inlet valves vary according to the size of the machine and its functional configuration. Standard PulseFlow® Fresh Water Make-up inlet valve is 2" except for the Alternate PulseFlow® option, in which case it requires a 3" inlet valve. PulseFlow® module valves receiving from the PulseFlow® tank or mid-module pumps) are 1.5" except for the 92048 model, or the 76039 model with the PulseFlow-EXD option, in which cases the valves are 2". Valves without an asterisk (*) are always the same size. Likewise, the facility's connection to the Fresh Water Make-up header is 2" or 3", according to the inlet valve size. The facility's connection to the remaining headers is 3".

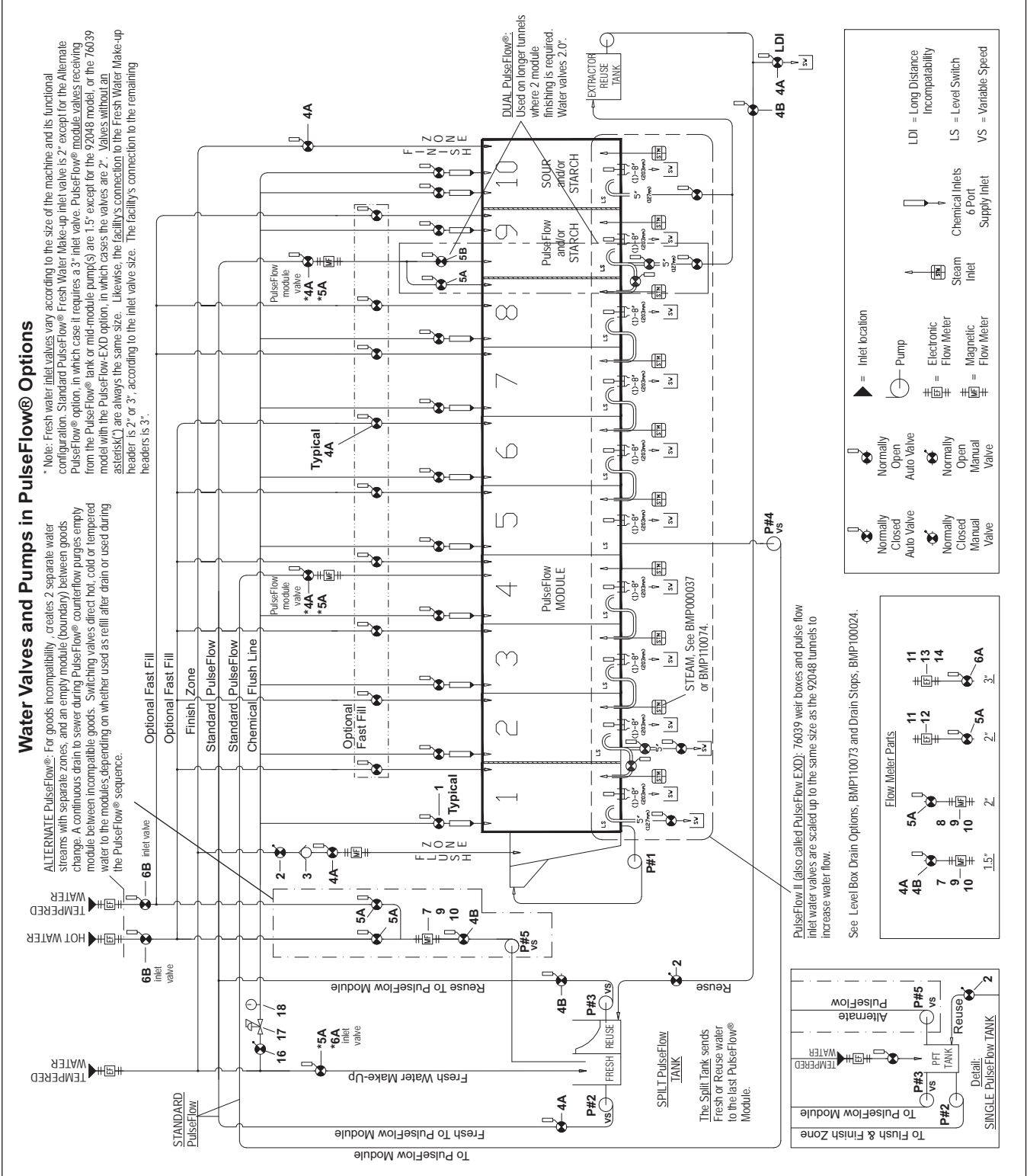

PulseFlow II (also called PulseFlow EXD): 76039 wet boxes and pulse flow inlet water valves are scaled up to the same size as the 92048 tunnels to increase water flow.

See Level Box Drain Options, BMP110073 and Drain Stops, BMP100024.

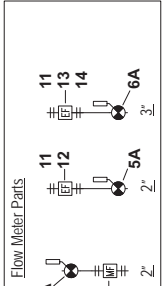
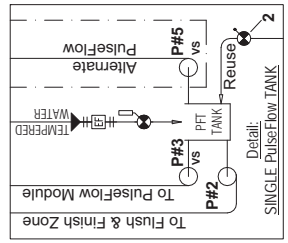

	Normally Closed Auto Valve		= Inlet location
	Normally Open Auto Valve		= Pump
	Normally Closed Manual Valve		= Electronic Flow Meter
	Normally Open Manual Valve		= Magnetic Flow Meter
	Steam Inlet		Chemical Inlets 6 Port
	Supply Inlet		LS = Level Switch
	Variable Speed		LDI = Long Distance Incompatibility

PulseFlow® Water Options: Schematic and Piping

76028, 76039, 92048 Pulse Flow Tunnels

Pump Chart

Pumps that vary with Tank and PulseFlow® Option: Use with parts list.

HP Pumps with Single PulseFlow® Tank					
Pump Locations	P#1	P#2	P#3	P#4	P#5
Pulse Flow Options:					
Standard Pulse Flow	3HP	3HP	5HP	7.5HP	—
Alternate Pulse Flow	3HP	3HP	5HP	7.5HP	5HP
PulseFlow II or PulseFlow EXD	3HP	3HP	7.5HP	7.5HP	—
Alternate Pulse Flow with PulseFlow II or PulseFlow EXD	3HP	3HP	7.5HP	7.5HP	7.5HP
HP Pumps with Split PulseFlow® Tank					
	VERTICAL PUMPS (greyed)				
Standard Pulse Flow	3HP	5HP	5HP	7.5HP	—
Alternate Pulse Flow	3HP	5HP	5HP	7.5HP	5HP
PulseFlow II or PulseFlow EXD	3HP	7.5HP	7.5HP	7.5HP	—
Alternate Pulse Flow with PulseFlow II or PulseFlow EXD	3HP	7.5HP	7.5HP	7.5HP	7.5HP

**P#4 is the Mid-Module Pump.
All pumps not greyed are horizontal.

Vertical Pumps

Pump #2 Pump #3



Horizontal Pumps (horizontal mounting before 01/2018)

Horizontal Pumps

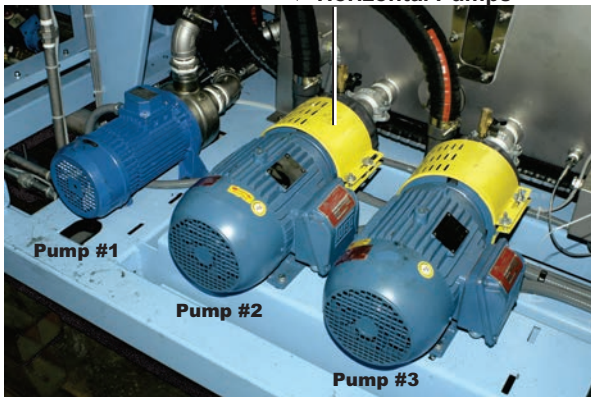

Pumps for Single PulseFlow® Tank

Optional Pump #5 Pump #2 Pump #3

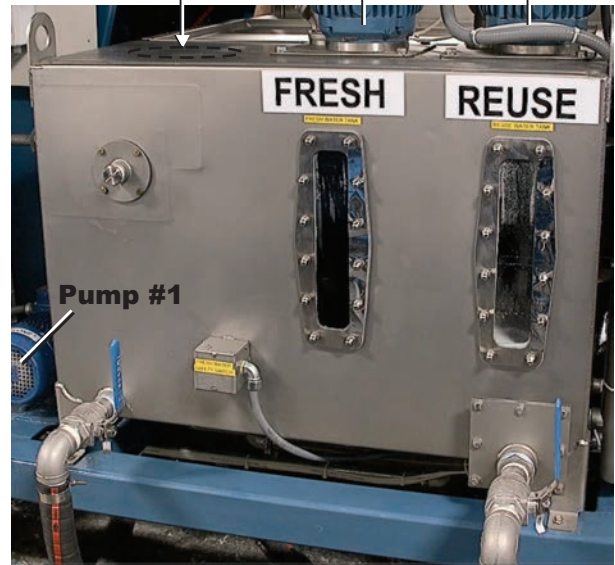

Split Tank (Optional 10/2017, Standard 1/2018)

PulseFlow® Water Options: Schematic and Piping

76028, 76039, 92048 Pulse Flow Tunnels

Inlets and Manifolds



Water Inlets
(One fresh water inlet to tank is standard; maximum is four.)



Bottom View Manifolds

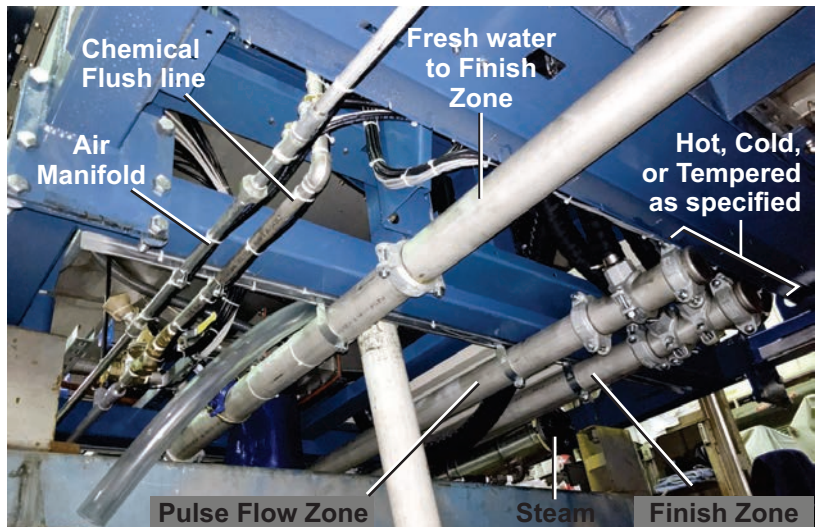

Bottom View Manifolds

PulseFlow® Water Options: Schematic and Piping

76028, 76039, 92048 Pulse Flow Tunnels

Pump Fittings

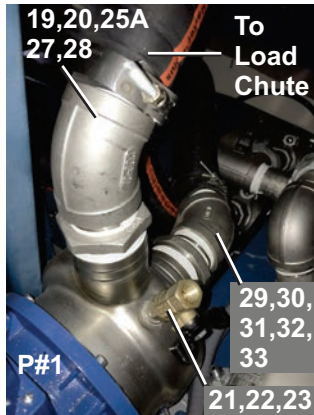

Pulse Flow Manifolds

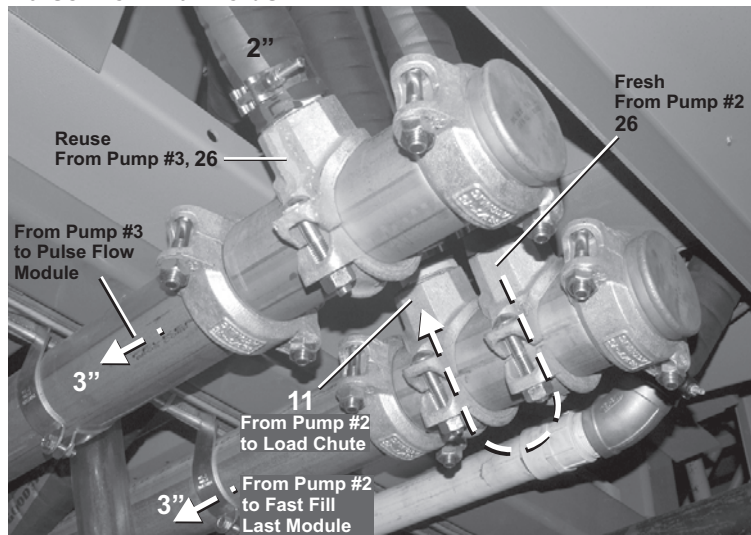

PulseFlow® Water Options: Schematic and Piping

76028, 76039, 92048 Pulse Flow Tunnels

Load Chute Recirculation

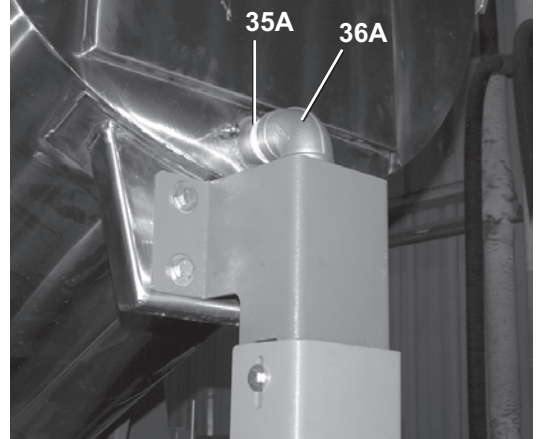
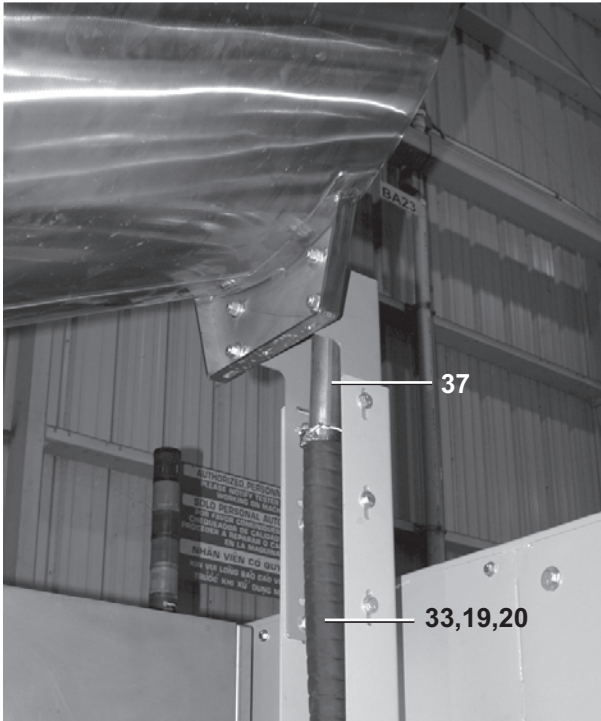

PulseFlow® Water Options: Schematic and Piping

76028, 76039, 92048 Pulse Flow Tunnels

Fast Fill, typical

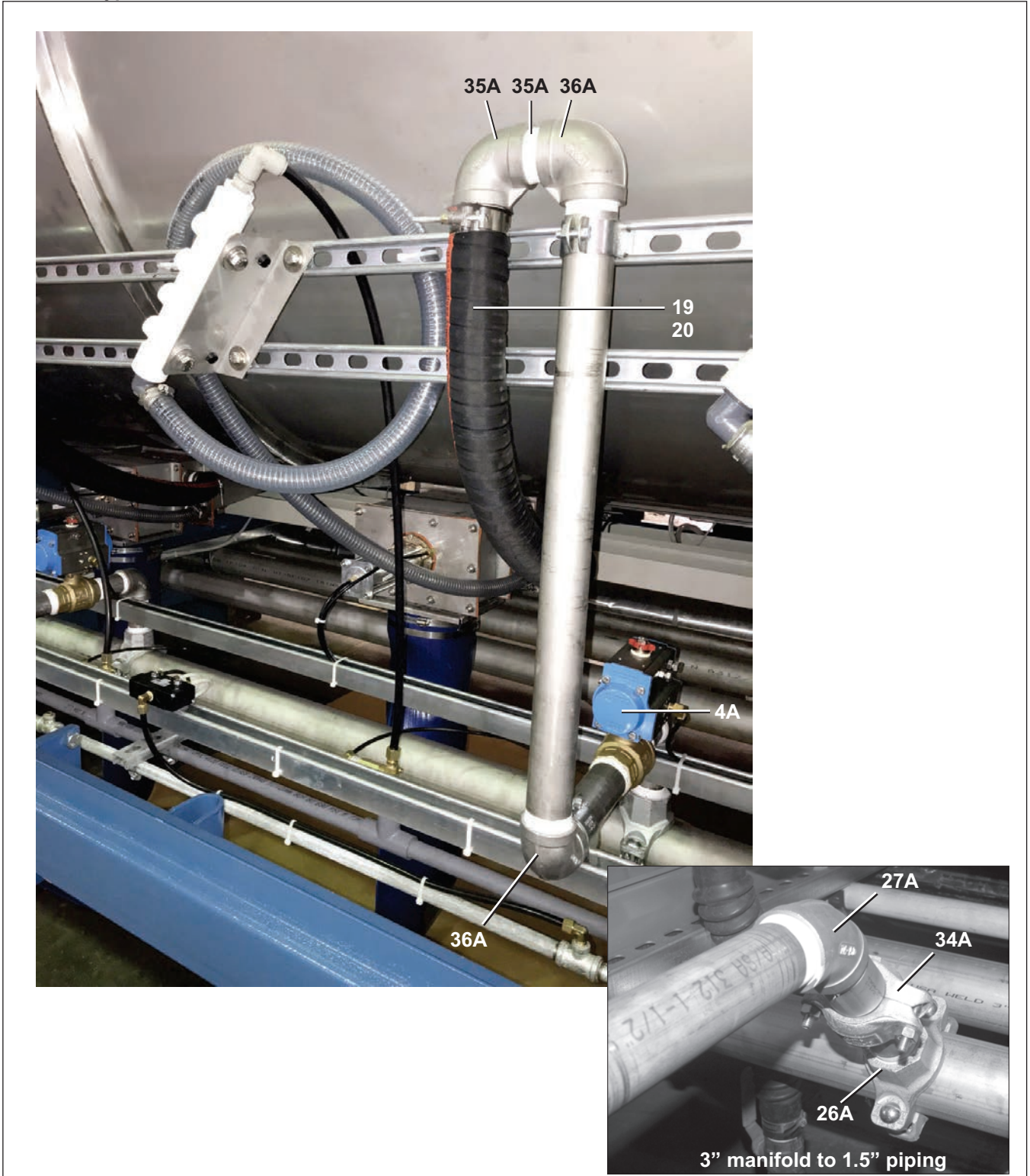

PulseFlow® Water Options: Schematic and Piping

76028, 76039, 92048 Pulse Flow Tunnels

PulseFlow® Module Inlet, typical

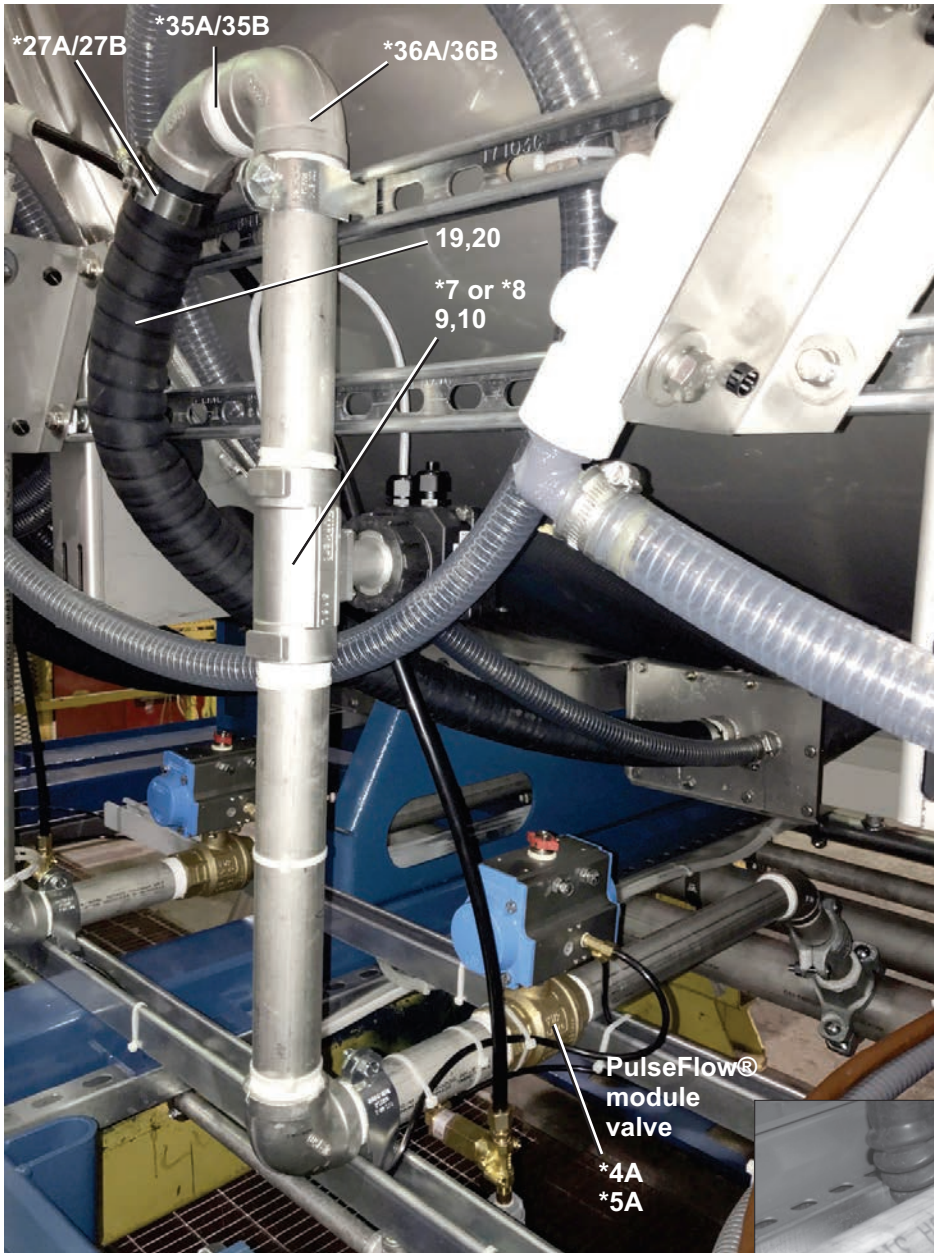

*PulseFlow® Module valve and piping may be 1.5" or 2", see parts list.

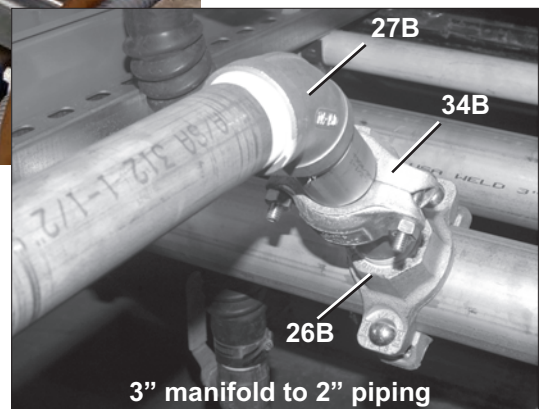

3" manifold to 2" piping

PulseFlow® Water Options: Schematic and Piping

76028, 76039, 92048 Pulse Flow Tunnels

Alternate PulseFlow® Valves

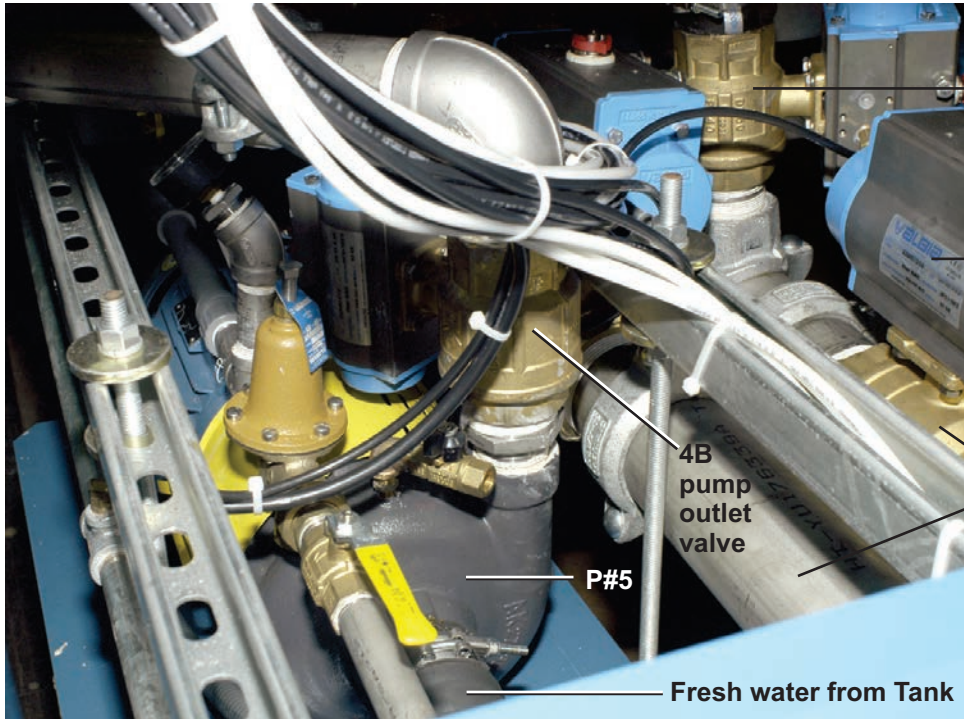

View A-A

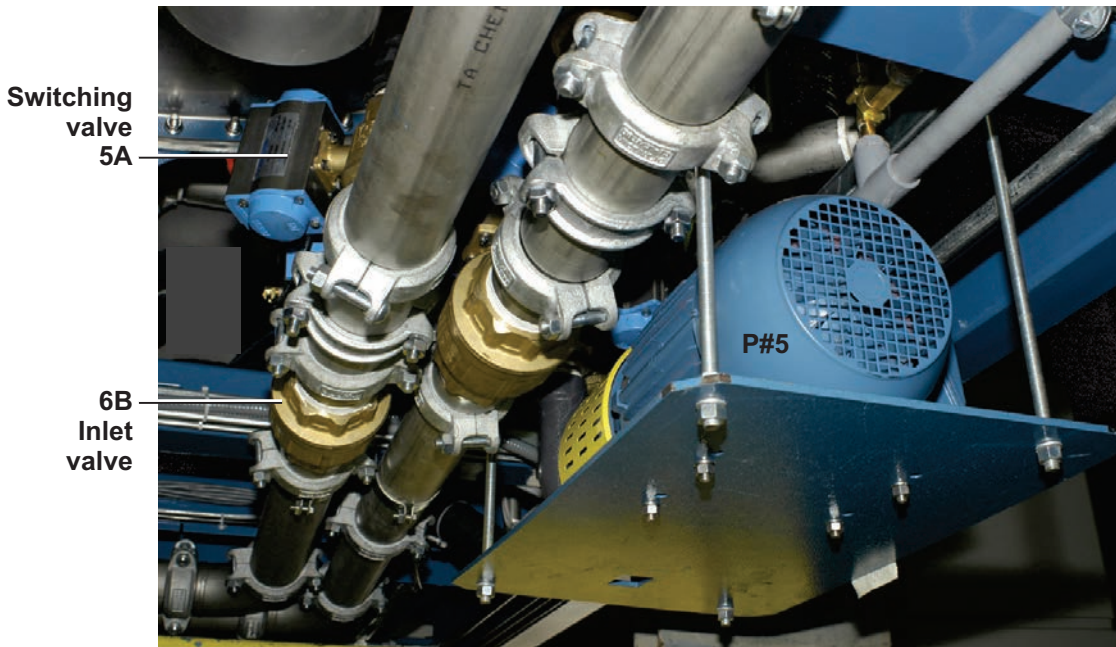

View B-B

PulseFlow® Water Options: Schematic and Piping

76028, 76039, 92048 Pulse Flow Tunnels

Alternate PulseFlow® Valves

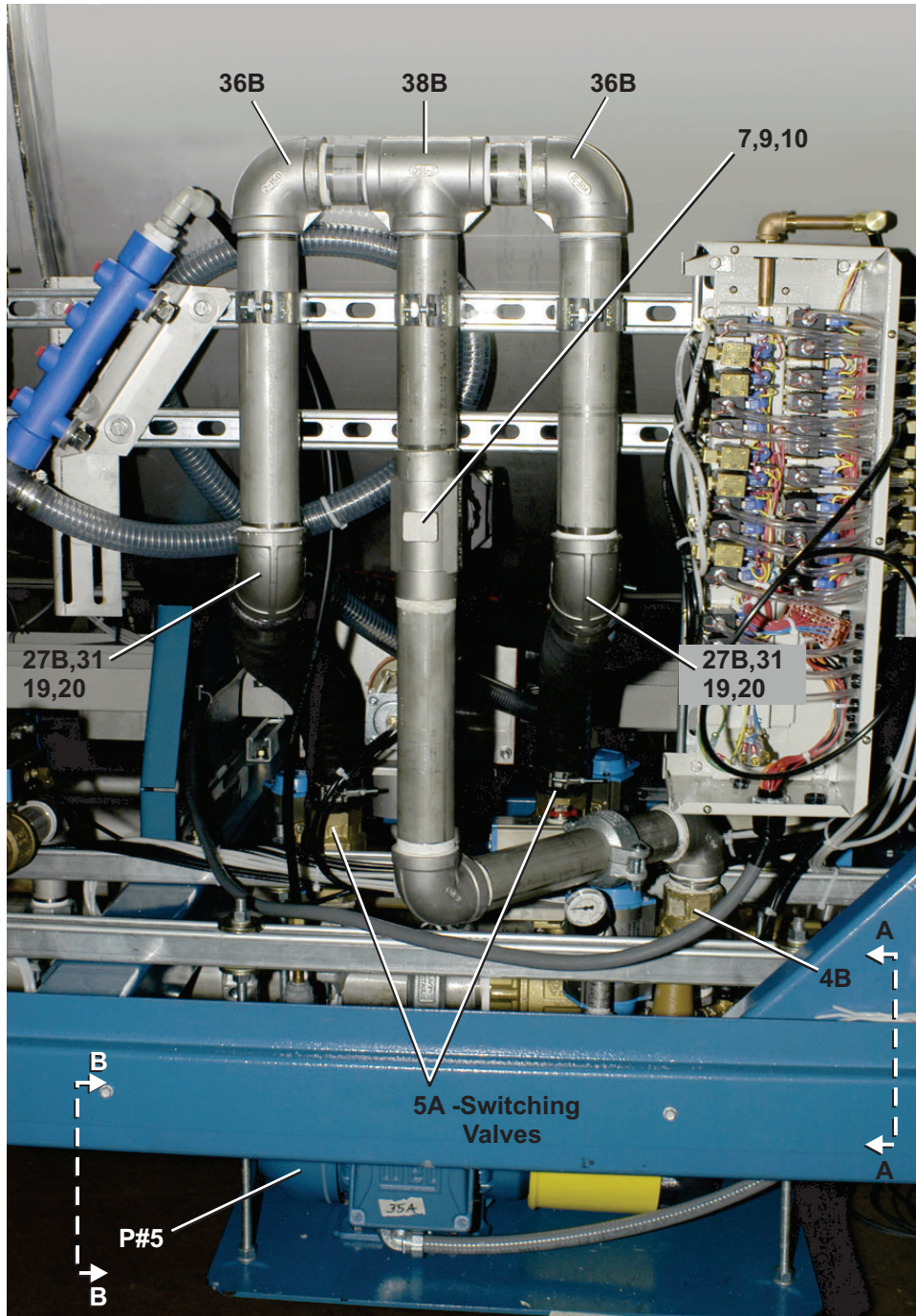

PulseFlow® Water Options: Schematic and Piping

76028, 76039, 92048 Pulse Flow Tunnels

Dual PulseFlow® Valves



*4A PulseFlow®
*5A module
valve

PulseFlow® Water Options: Schematic and Piping

76028, 76039, 92048 Pulse Flow Tunnels

Mid-Module Pump(P#4) & Alternate Pulse Flow Pump(P#5)

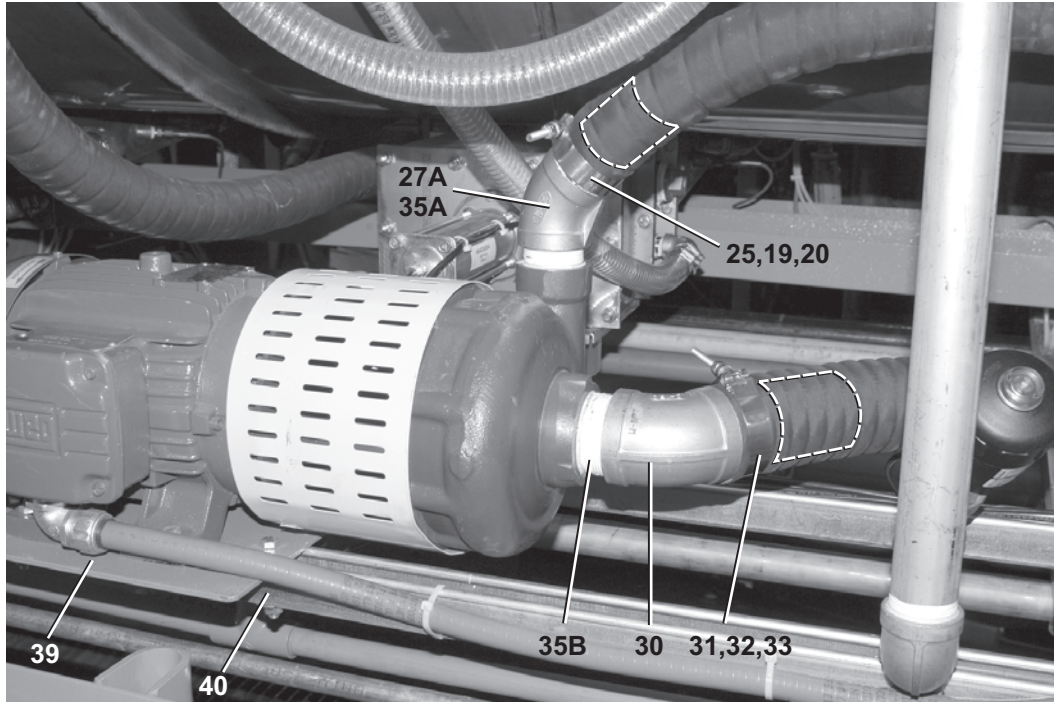

Pump Rail Mounting

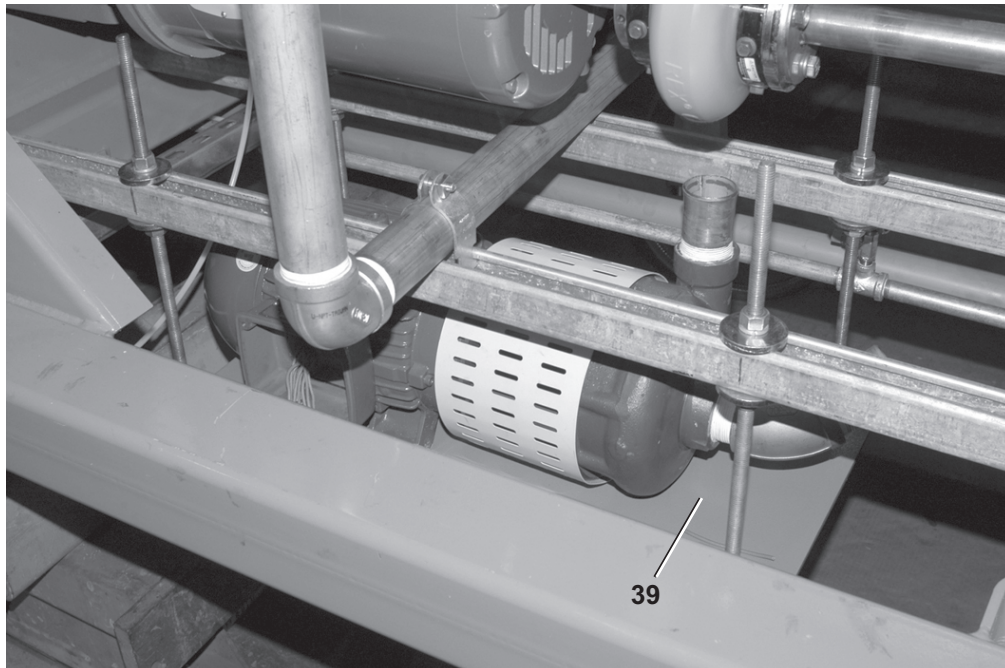

Pump Suspended Mounting

PulseFlow® Water Options: Schematic and Piping

76028, 76039, 92048 Pulse Flow Tunnels

Parts List

Find the correct assembly first, then find the needed components. The item letters (A, B, C, etc.) assigned to assemblies are referred to in the "Used In" column to identify which components belong to an assembly. The item numbers (1, 2, 3, etc.) assigned to components relate the parts list to the illustration.

Used In	Item	Part Number	Description	Comments
	(H) (V)		REFERENCE REFERENCE	Horizontal Pump Vertical Pump
-----PUMPS SINGLE TANK-----				
	P#1 (H) P#2 (H) P#3,5 (H) P#3,5 (H) P#4 (H)	27E935G96 27E934A96 27E935A96 27E936A96 27E936B96	PUMP EBARA DWO 3006 3HP 230/460 PUMP 2"X1.5" W/ 4.25" IMPELLER 3HP PUMP 2X1 1/2 W/4.75 IMPELLER 5HP PUMP 2"X1.5" W/5.25" IMPELLER 7.5 HP PUMP S/S VORTEX 2"X1.5" W/ 6.25" IMPELLER 7.5HP	3HP HORIZONTAL 3HP HORIZONTAL 5HP HORIZONTAL 7.5HP HORIZONTAL 7.5HP VORTEX HORIZ.
-----PUMPS SPLIT OR DUAL TANK-----				
	P#1 P#2,3,5(V) P#2,3,5(V) P#4(H)	27E935G96 27E935A96V 27E936A96V 27E936B96	PUMP EBARA DWO 3006 3HP 230/4603 PUMP VERTICAL 2X1 1/2 W/4.75 IMPELLER 5HP PUMP VERTICAL 2"X1.5" W/5.25 IMPELLER 7.5HP PUMP S/S VORTEX 2"X1.5" W/6.25" IMPELLER 7.5HP	3HP HORIZONTAL 5HP VERTICAL 7.5HP VERTICAL 7.5HP VORTEX HORIZ.
-----VALVES-----				
all	1	96TBC2AA01	1/4" N/C 1WAY AIR-OP VLV POLYPRO(NO COIL)	
all	2	96D087FSLH	1.5" BALVAL S/S LLHDL BONOMI #700LL-1.5	
all	3	96D087BCK	CK VAL 1.5"WATTS#600-Z3 W/S/S DISH(SPECIAL)	
	4A 4A	96D087FBA 96D087FSB	1.5"BALVAL+ACT BRS N/C BONOMI (SPRING RET) 1.5" BALVAL+ACT S/S BONOMI SPRING RETURN N/C	STAINLESS OPTION
	4B 4B	96D087FBAO 96D087FSAO	1.5"BALVAL+ACT BRS N/O BONOMI (SPRING RETURN) 1.5" BALVAL+ACT SPRING RETURN S/S BONOMI N/O	STAINLESS OPTION
	5A 5A	96D088FBA 96D088FSAS	2" BALVAL+ACT BRS N/C BONOMI (SPRING RET) 2" BALVAL+ACT S/S N/C BONOMI (SPRING RETURN)	
	5B	96D088FBAO	2"BALVAL+ACT BRS N/O BONOMI (SPRING RETURN)	
	6 6	96D090FBA 96D090FBAO	3"BALVAL+ACT BRS N/C SPRING RET BONOMI 3"BALVAL+ACT BRS N/O SPRING RET BONOMI	
all	7	30F568	MAGMETER FITTING 316SS 1.5"	
all	8	30F570	MAGMTR FITTING 316S/S 2"	
all	9	30F580	8041 BLIND UNIT MAG SENSOR SHORT FINGER	
all	10	30F580A	8025 LOWFLOW WALL-MNT TRANSMIT	
all	11	30F515	FLOW SENSOR SIGNET #P51530-PO	
all	12	30F519A	2" SADDLE FITTING #IR8S020 PADDELWHEEL	
all	13	5R3A1ECI	NPT SADDLE 3X1.25 CI 300# SB	
all	14	30F516	ADFOR 2.5" + 3" SADDLE SIGNET	
all	16 16	96D050A 96D055FSH	3/4"BALLVALVE BRZ = BONOMI 171N 3/4" BALVAL S/S BONOMI#700023	BRASS STAINLESS OPTION
all	17	96J031D	3/4"PRESSREG SET 28#	
all	18	30N100	PRESSGAUGE 1/8"BACKCN.0-30PSI	
all	19	27A072	T-BOLT HOSECLAMP2.16-2.47CADSC	
all	20	60E255	HOSE 2" ID X 2.45" OD WATER CORRUGATED 50 FEET	

PulseFlow® Water Options: Schematic and Piping

76028, 76039, 92048 Pulse Flow Tunnels

Parts List

Find the correct assembly first, then find the needed components. The item letters (A, B, C, etc.) assigned to assemblies are referred to in the "Used In" column to identify which components belong to an assembly. The item numbers (1, 2, 3, etc.) assigned to components relate the parts list to the illustration.

Used In	Item	Part Number	Description	Comments
all	20	60E255E	HOSE 2" EPDM WATER CORRUGATED(V50)50'	EPDM FOR REUSE WATER
all	21	96D021	1/4" BALVLV BRZ-BONOMI #172N-1/4" W /T-HANDLES	
all	21	96D021S	1/4" BALVLV 304SS W /T-HANDLE	
all	22	5SB0E0CBEO	NPTHEXBUSH 1/4X1/8 BRASS 125#	
all	23	5N0CCLSB42	NPT NIP 1/8XCLS TBE BRASS STD	
all	25	5N1K03AS41	NPT NIP 1.5X3 TOE 304SS SK40	
all	25	5N2A04AS41	NPT NIPPLE 2X4 TOE 304SS	
all	26	51V352	MECH-T 3X1.5FEM #920N GALV	
all	26	51V353	MECH-T 3X2 #920N FEM GALV	
all	27	5SL1KSFK	NPT ELBOW 45DEG 1.5" 304SS 150	
all	27	5SL2ASFK	NPT ELBOW 45DEG 2" 304SS 150#	
all	28	5SB2A1KSFO	NPTHEXBUSH 2X1.5 304SS 150#	
all	29	5SB2K1KSFO	NPTHEXBUSH 2.5X1.5 304SS 150#	
all	31	5N2A03AS41	NPT NIPPLE 2X3 TOE 304SS Sk40	
all	32	27A075	T-BOLT HOSECLAMP 2.78-3.09"	
all	32	27A075B	T-BOLT HOSE CLAMP-2.66-2.94 (STBC288)	
all	33	60E301	HOSE 2.5"WATER CORRUGATED(V50)	
all	33	60E301E	HOSE 2.5" EPDM WATER CORRUGATED(V50) 50'	EPDM FOR REUSE WATER
all	34	27E971D	VICT COUP 1.5"GALV #75	
all	34	27E971C	VICT COUP 2"GALV #75W/E GASKET	
all	34BG	27E971CG	E GASKET FOR 2" # 75 COUPLING	
all	34	27E972A	VICT COUP 3"GALV#75 W/E"GSKT	
all	34CG	27E972AG	E GASKET FOR 3" #75 COUPLING	
all	35	5N1KCLSS42	NPT NIP 1.5XCLS TBE 304SS SK40	
all	35	5N2ACLSS42	NPT NIP 2XCLS TBE 304SS Sk40	
all	36	5SL1KSFA	NPT ELB 90DEG 1.5 304SS 150#	
all	36	5SL2ASFA	NPT ELBOW 90DEG 2" 304SS 150#	
all	37	5N1K12KS41	NPT NIPPLE 1.5X12.5 TOE 304SS	
all	38	5S2ASFA	NPT TEE 2" 304SS 150#	
all	39	06 30215	PUMP MNT MID MOD 7639	
all	39	06 30216	MID MOD PUMP MNT 9248	
all	40	27A0200	CLP-RGDSTL PS#1100-2 10/BAG	

Standard Large Split PulseFlow® Tank

76028, 76039, 92048 PulseFlow® Tunnels

Figure 1: Tank Components



Standard Large Split PulseFlow® Tank

76028, 76039, 92048 PulseFlow® Tunnels

Figure 2: Tank Components

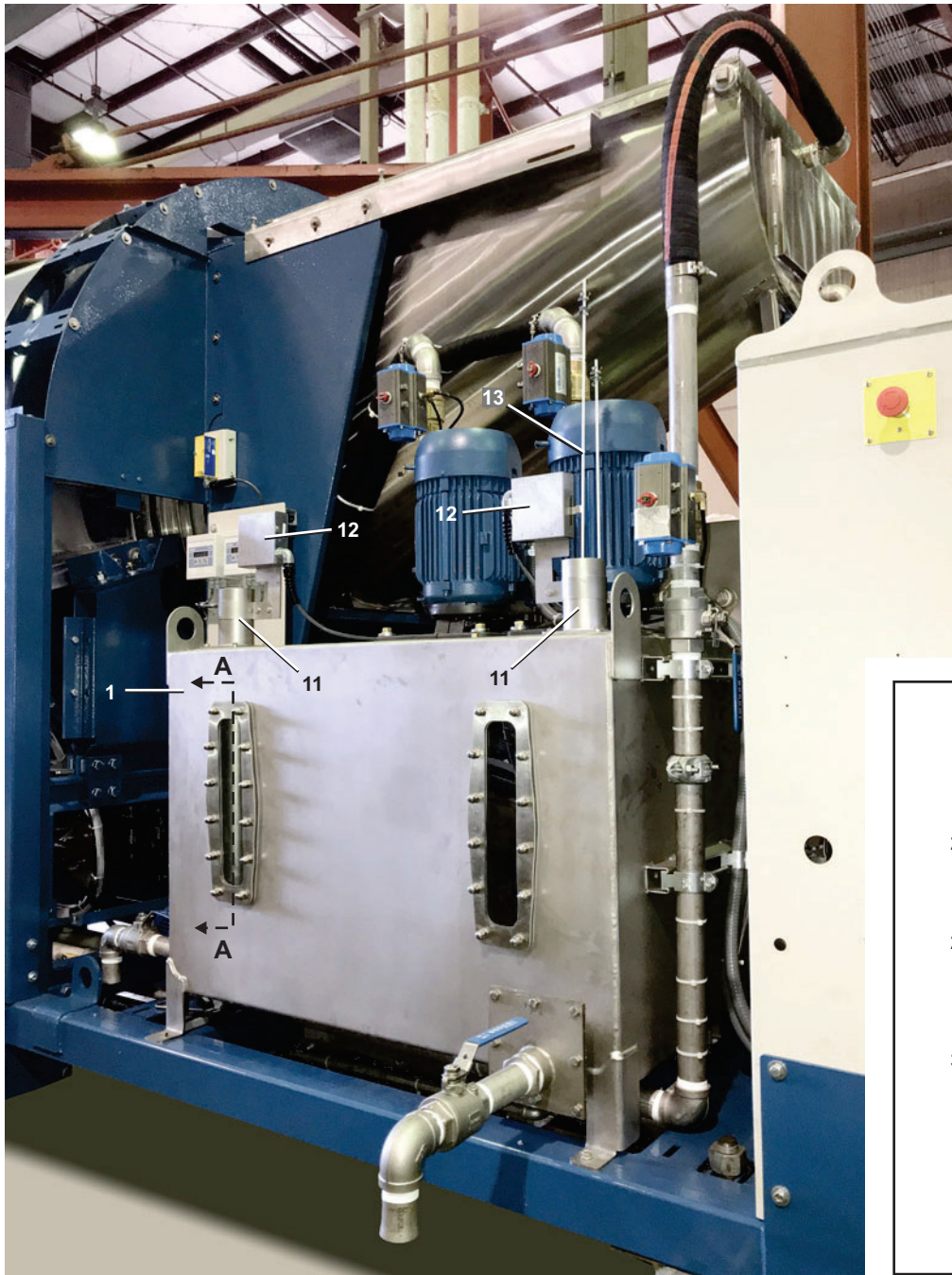

Standard Large Split PulseFlow® Tank

76028, 76039, 92048 PulseFlow® Tunnels

Figure 4: Pumps, Valves, Probes, and Sensors

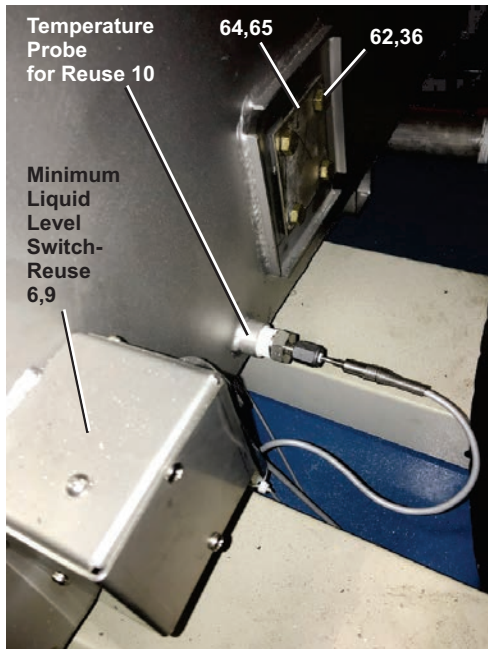

View B-B

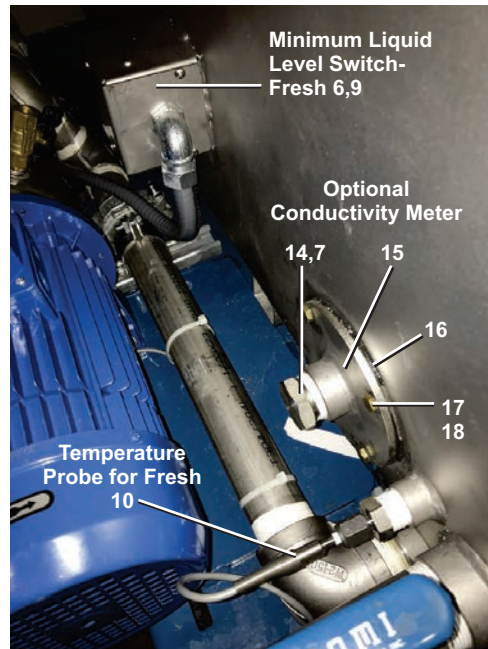

View C-C

Standard Large Split PulseFlow® Tank

76028, 76039, 92048 PulseFlow® Tunnels

Figure 5: Drains, Water and Air Nozzels

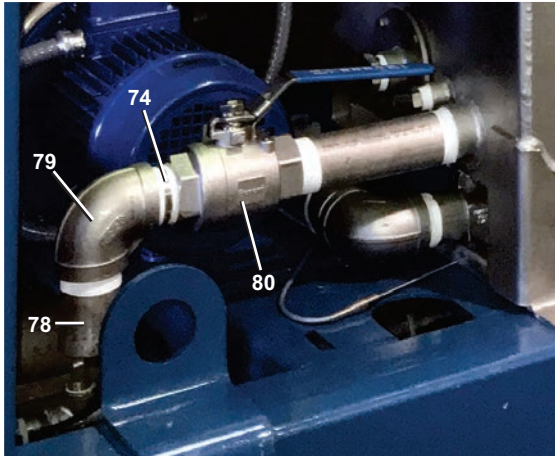

Standard Manual Drain - Fresh

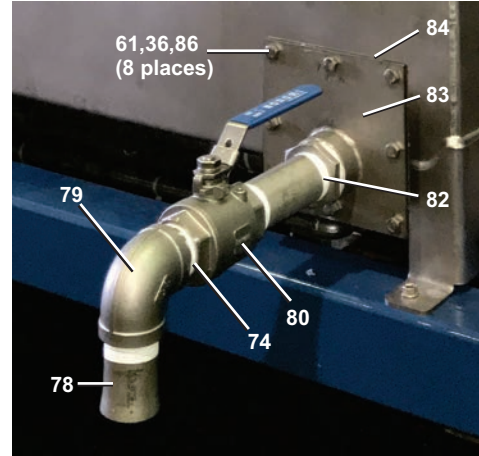

Optional Manual Drain - Reuse

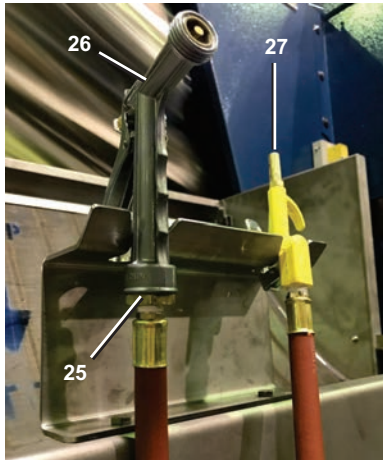

Water and Air Nozzles

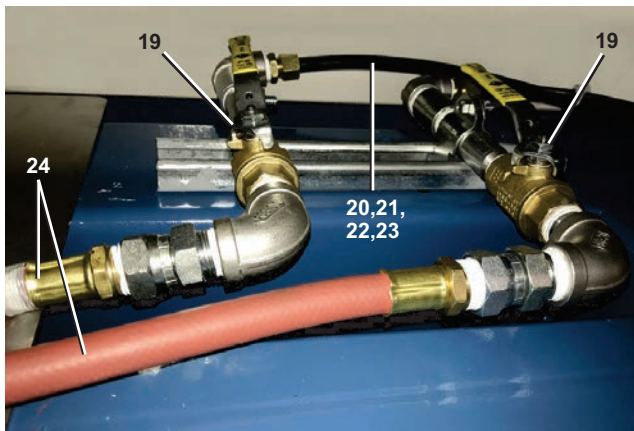

View D-D

Optional 4" Auto Drain - Reuse

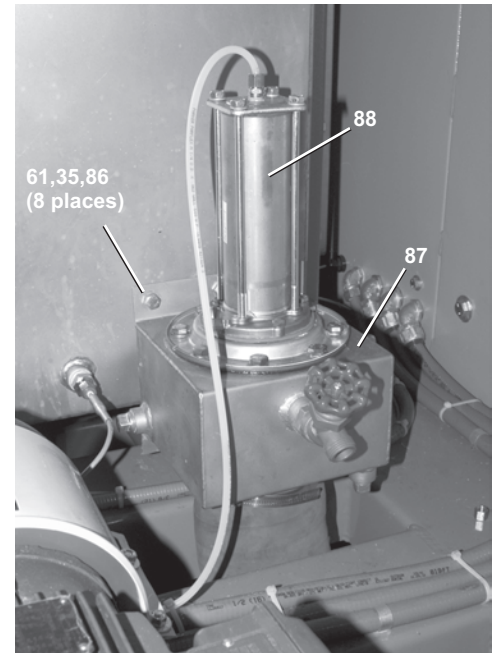

Standard Large Split PulseFlow® Tank

76028, 76039, 92048 PulseFlow® Tunnels

Figure 3: Wedge Wire Sub-assembly

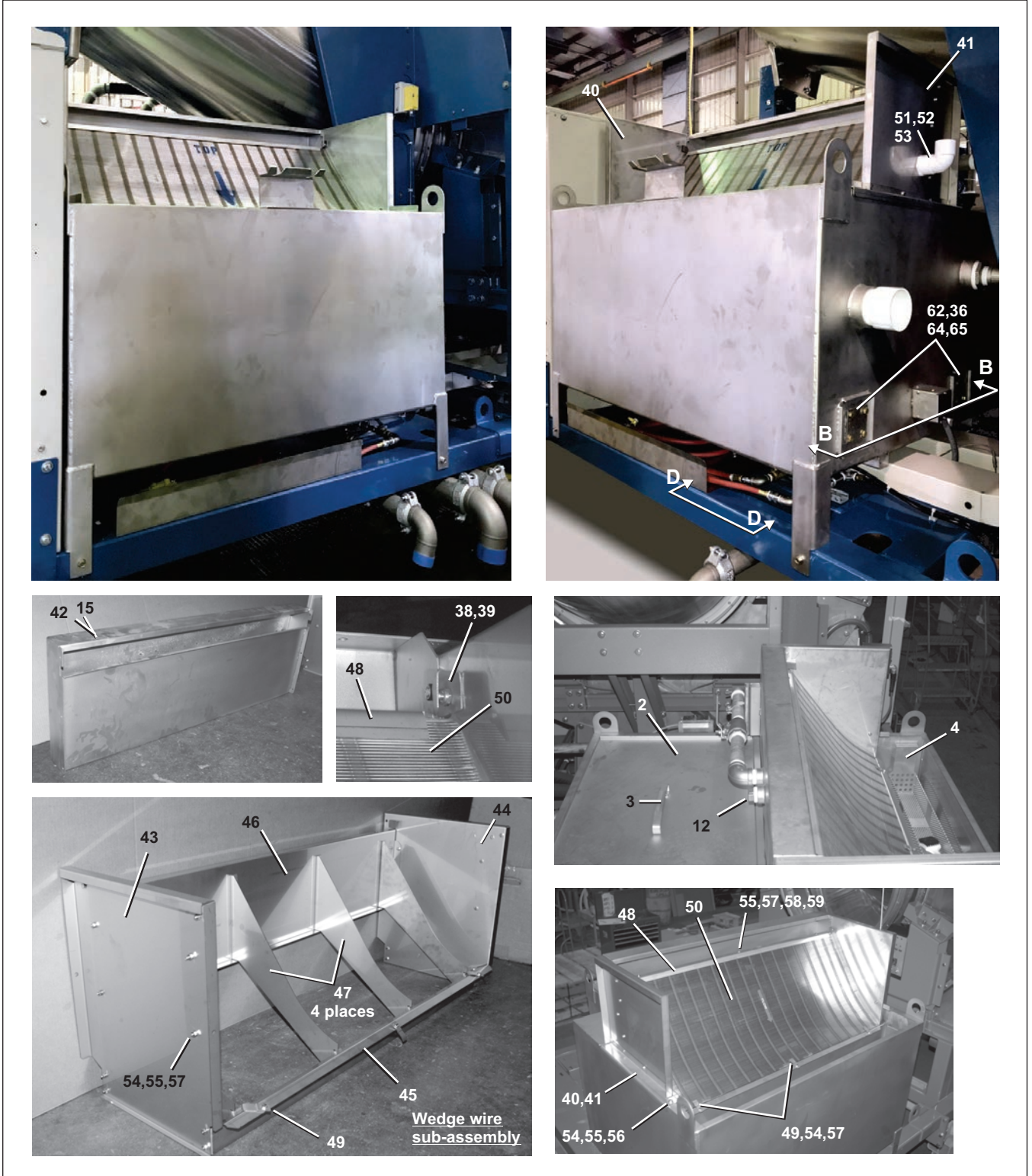

Standard Large Split PulseFlow® Tank

76028, 76039, 92048 PulseFlow® Tunnels

Parts List—Standard Large Split PulseFlow Tank				
Find the correct assembly first, then find the needed components. The item letters (A, B, C, etc.) assigned to assemblies are referred to in the "Used In" column to identify which components belong to an assembly. The item numbers (1, 2, 3, etc.) assigned to components relate the parts list to the illustration.				
Used In	Item	Part Number	Description	Comments
-----REFERENCE ASSEMBLIES-----				
	A	A62 03900Z	ASSY=PULSEFLOW DUAL TANK LARGE	
	B	A62 03900ZS	ASSY=PULSEFLOW DUAL TANK LARGE SS VALVES	
	C	A62 03902Z	ASSY=PULSEFLOW DUAL TANK-9248	
	D	A62 03901Y	PULSEFLOW TANK WEDGEWIRE DUAL TANK	
	E	G65WV009	INTS=G3 DUAL PULSEFLOW TANK PUMP PIPING	
	F	G67CL009	INST=AIR/WATER NOZZLES DUAL PULSEFLOW	
	G	A67CL008	ASSY=AIR/WATER NOZZLES PULSEFLOW SCREEN	
	H	G62 03900B	INST=SIGHT GLASS DUAL TANK LARGE	
-----COMPONENTS-----				
A,B	1	W6 70234C	WLMT=PULSEFLOW DUAL TANK LARGE	
C	1	W6 70234D	WLMT=PULSEFLOW DUAL TANK-9248	
A,B	2	W6 70245A	WLMT=PULSEFLOW DUAL TANK COVER-LARGE	
C	2	W6 70245B	WLMT=PULSEFLOW DUAL TANK COVER-9248	
all	3	02 175037	HANDLE=SHELDOR=WED-SS	
all	4	W6 20579	LINT TRAY WMT-250G SURGE TNK	
all	6	03 E32EP	COVER=SAFETY LEVEL SWITCH-DEEP	
all	7	09XSCD0001	ROSEMOUNT 226 CONDUCTIVITY TOROIDAL	
all	8	09XSPH0001	ROSEMOUNT PH 3900VP	
all	9	09RL001	LIQUID LEVEL SW. SIDE MOUNT-- GEMS #131100	
all	10	30R0043PSA	TEMPERATURE PROBE ASSY=S/S	
all	11	A67LS003A	LEVEL SW ASSY - DUAL TANK	
all	12	ELL000MK2	*WATER LEV SW ASSY: 1 UP+ 1LO	
all	13	SA 02 011A	*FLOAT ASSY L=44"	
all	14	5SP1ASFSS	NPT PLUG 1" HEXSOLID 304SS	
all	15	W6 70286	WLMT=CONDUCT METER FLANGE	
all	16	06 40069G	N/C DBL ACT DYE DMP VLV GSKT	
all	17	24G020N	ROLLED WASH.252ID NYLTITE 25W	
all	18	15K035A	HEXCAPSCR 1/4-20 X 3/4 BRASS	
all	19	96D034	BALL VLV - BONOMI 1/2" 171S SS BALL/STEM	
all	20	60E005F	TUBING NYL.BLK.1/2"ODX.375ID	
all	21	53A10SSKB	.5T COMPNUT 11/16-20 AND#61A-8	
all	22	53A3000KB	SLEEVE 1/2"OD TUBE #60AP-8	
all	23	53A4000KB	TUBE INSERT 1/2"OD #60AE-8	
all	24	60E077B068	HOSE ASSY 3/8"X68"+ENDS	
all	25	51E513A	3/4"MHX1/4"FP PARKER#78GH-12-4	
all	26	27A012N	WATER NOZZLE-PULSE FLOW SCREEN	
all	27	97Q200T	AIR GUN,1/4"NPT INLET,OSHA APP	
all	28	02 19128	CLAMPRING=LEVEL IND	
all	29	02 18657	SIGHTGLASS=LEVELINDICATOR	
all	30	02 18940D	LEVEL IND GASKET-OUTER DYA	
all	31	02 18941	GASKET=SIGHT GLASS-INNER 1/8	
all	32	02 18941A	GASKET=SIGHT GLASS-INNER 3/3	
all	33A	03 06122A	MARKER LEVEL PULSE FL GALS/LITER	
all	33B	03 06122B	MARKER LVL PULSE FRESH GALS/LITER	
all	33C	03 06122C	MARKER LVL PULSE REUSE GALS/LITER	
all	34	15G200SS	HEXCAPNUT HIGH-CR 3/8-16 SS 1	
all	35	15U260	LOCKWASHER MEDIUM 3/8 SS18-8	
all	36	24G030N	ROLLED WASH.379ID NYLTITE 37W	
all	37	15G206	HEXNUT 3/8-16 UNC2 SS 18-8	
all	38	W6 20414	*WLDMT=DEFLECTOR WW LF HAND	
all	39	W6 20415	*WLDMT=DEFLECTOR WW RT HAND	
all	40	06 70264	WEDGEWIRE TANK MOUNT BRKT	

Standard Large Split PulseFlow® Tank

76028, 76039, 92048 PulseFlow® Tunnels

Parts List

Find the correct assembly first, then find the needed components. The item letters (A, B, C, etc.) assigned to assemblies are referred to in the "Used In" column to identify which components belong to an assembly. The item numbers (1, 2, 3, etc.) assigned to components relate the parts list to the illustration.

Used In	Item	Part Number	Description	Comments
all	41	06 70264A	WEDGEWIRE TANK MOUNT BRKT OPP	
all	42	W6 70238	PULSEFLOW TANK WEDGEWIRE SUBASSEMBLY	
all	43	06 70268B	TANK INLET PARTITION LEFT DUAL TANK	
all	44	06 70268C	TANK INLET PARTITION RIGHT DUAL TANK	
all	45	06 70210	WEDGE WIRE FRAME LOWER SUPP	
all	46	06 70211	WEDGE WIRE FRAME UPPER SUPP	
all	47	06 70213	WEDGE WIRE GUSSET	
all	48	06 70214	WEDGE WIRE HOLD DOWN BAR	
all	49	06 20404L	48" LINT TANK FILTER HOLDER	
all	50	06 20404B	SCREEN=48" LINT WEDGE WIRE	
all	51	12M043L150	LOCKNUT 1-1/2" NPT PVC	
all	52	5KL1KP4N	SOC STREET EL 1.5" 90 DEG SLIPXSLIP	
all	53	5KC1KP4E	ADAPTER 1.5 SXMPT PVC SCH40	
all	54	15N158	HEXCAPSCR 1/4-20NCX1/2SS18-8	
all	55	15U181	LOCKWASHER MEDIUM 1/4 SS18-8	
all	56	15G170	HEXNUT 1/4-20UNC2 SS18-8	
all	57	15G164	HX THIN LOCKNUT NYL1/4-20 SS	
all	58	15K142	HXCAPSCR 3/8-16X6 GR8ZC	
all	59	15U188	FLTWASH 1/4 STD COMM SS18-8	
all	60	15P200	TRDCUT-F HXWASHD 3/8-16X3/4NIK	
all	61	15K096	HEXCAPSCR 3/8-16UNC2X1SS18-8	
all	62	15K096A	HXCPCSCR.3/8-16X1SS18-8.123HD.H	
all	64	06 20297B	GASKET=DYE CBW STEAM FLANGE	
all	65	06 20298A	PLATE FLANGE NO STEAM	
all	66	06 70320	VERTICAL PUMPP MNT COVER	
all	67	27E936A96V	PUMP VERTICAL 2"X1.5" W/5.25" IMPELLER 7.5 HP	
all	68	15K190B	HEXCAPSCR 1/2-13X2.5 FULLTHRD BRASS	
all	69	15U310S	FLATWASH-SS .53 X 1.37 .187T	
all	70	15U315S	LOKWASHER MEDIUM 5/8 18-8 S/S	
all	71	5N1K13AS42	NPT NIPPLE 1.5X13 TBE 304SS SK	
all	72	96D087FBA	1.5"BALVAL+ACT BRS N/C BONOMI (SPRING RET)	N/C BRASS
all	72	96D087FSB	1.5" BALVAL+ACT S/S BONOMI SPRING RETURN N/C	N/C STAINLESS
all	73	96D087FBAO	1.5"BALVAL+ACT BRS N/O BONOMI (SPRING RETURN)	N/O BRASS
all	73	96D087FSAO	1.5" BALVAL+ACT SPRING RETURN S/S BONOMI N/O	N/O STAINLESS
all	74	5N1KCLSS42	NPT NIP 1.5XCLS TBE 304SS SK40	
all	75	5N1K03AS41	NPT NIP 1.5X3 TOE 304SS SK40	
all	76	5SL1KSFK	NPT ELBOW 45DEG 1.5" 304SS 150	
all	77	6.00E+256	HOSE 2" ID X 2.45" OD WATER CORRUGATED 50 FEET	
all	78	27A072	T-BOLT HOSECLAMP2.16-2.47CADSC	
all	79	5SL1KSFA	NPT ELB 90DEG 1.5 304SS 150#	
all	80	96D087FSHL	1.5" BALVAL S/S LLHDL BONOMI #700LL-1.5	
all	82	5SB2A1KSFO	NPTHEXBUSH 2X1.5 304SS 150#	
all	83	W6 70295	WLMT=PULSE FLOW DRAIN	
all	84	02 15026	GASKET-7"SQ=4"FLGDUMP VALVE	
all	86	15G206B	HEXNUT 3/8-16UNC2 BRASS	
all	87	W2 15997	* BODY=4"DUMPVALVE=4231WE+SG	
all	88	A64DV009	ASSY=4" DUMP VALVE N/C PULSE FLOW	

Pulse Flow Tank Fresh Water Piping

76028G3, 76039G3, 92048G4

Figure 1: Fresh Water to Tank



Pulse Flow Tank Fresh Water Piping

76028G3, 76039G3, 92048G4

Figure 2: Reuse Water from Press to Tank

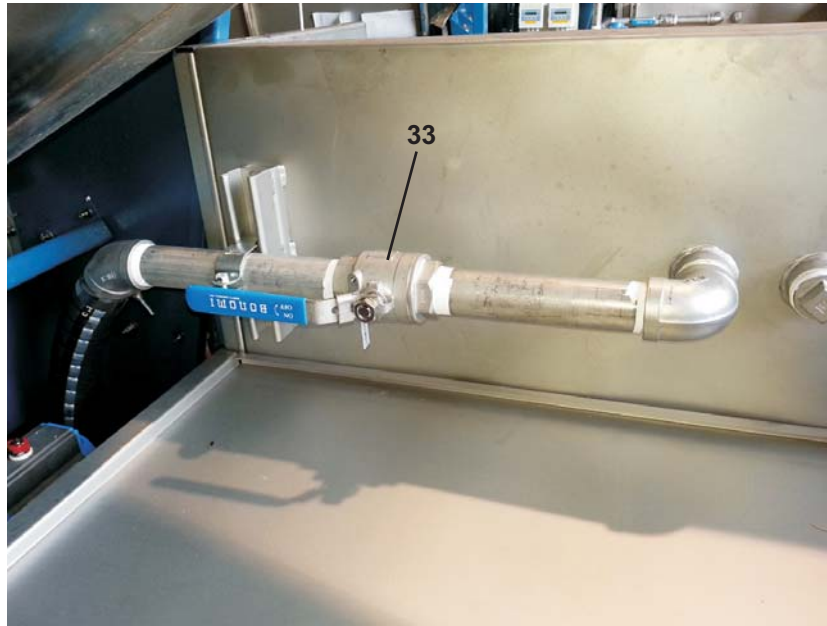

Press Reuse Water to Pulse Flow Tank

Parts List

Find the correct assembly first, then find the needed components. The item letters (A, B, C, etc.) assigned to assemblies are referred to in the "Used In" column to identify which components belong to an assembly. The item numbers (1, 2, 3, etc.) assigned to components relate the parts list to the illustration.

Used In	Item	Part Number	Description	Comments
-----ASSEMBLIES-----				
	A	A67PF001	G3 2" PULSE FLOW TANK FRESH WATER INLET	REFERENCE
	B	A63PF001	G4 2" PULSE FLOW TANK WATER INLET ASSY	REFERENCE
	C	A67PF001A	G3 3" PULSE FLOW TANK WATER INLET ASSY	REFERENCE
	D	A63PF002	G4 3" PULSE FLOW TANK WATER INLET ASSY	REFERENCE
-----COMPONENTS-----				
AB	1	51J120STS	ELB PIPE 90DEG 2"VICT#18 304S	
CD	1	51J145BSPS	EL90DEG 3"VICT#18/304BRITISHTH	
AB	2A	27E971C	VICT COUP 2"GALV #75W/E GASKET	
	2AA	27E971CG	E GASKET FOR 2" # 75 COUPLING	
CD	2B	27E972A	VICT COUP 3"GALV#75 W"E"GSKT	
	2BB	27E972AG	E GASKET FOR 3" #75 COUPLING	
AB	3	5N2A52AS41	NPT NIP 2X52 TOE 304SS SK40	
CD	3	5N3A52AS41	NPT NIP 3X52 TOE 304 S/S SK40	
all	4	30F515	FLOW SENSOR SIGNET #P51530-PO	
all	5	30F519A	2" SADDLE FITTING #IR8S020	
all	5	5R3A1ECI	NPT SADDLE 3X1.25 CI 300# SB	
all	6	15N101	SEMPANSL0TSCR 10-24X1/4 GR-2	
all	7	5SL2ASFA	NPT ELBOW 90DEG 2" 304SS 150#	

Pulse Flow Tank Fresh Water Piping

76028G3, 76039G3, 92048G4

Parts List				
Find the correct assembly first, then find the needed components. The item letters (A, B, C, etc.) assigned to assemblies are referred to in the "Used In" column to identify which components belong to an assembly. The item numbers (1, 2, 3, etc.) assigned to components relate the parts list to the illustration.				
Used In	Item	Part Number	Description	Comments
all	7	5SL3ASFA	NPT ELBOW 90DEG 3" 304SS 150#	
AB	8	5N2A04AS42	NPT NIP 2X4 TBE 304SS	
CD	8	5N3A03AS42	NPT NIP 3X3 TBE 304 SS SK40	
AB	9	5N2A13AS42	NPT NIP 2X13 TBE 304SS SK40	
CD	9	5N3A13AS42	NPT NIP 3X13 TBE 304 S/S SK40	
AB	10	5S2ASFA	NPT TEE 2" 304SS 150#	
CD	10	5S3ASFA	NPT TEE 3" 304S/S 150#	
all	11	5SB3A2ASFO	NPTHEXBUSH 3X2 304SS 150#	
all	12	5SB2A0KUFO	NPTHEXBUSH 2X1/2 316SS 150#	
all	13	53ACM0KKB	ASSY MALECON.5TX .5MP BRASS 68	
AB	14	96D088FBA	2" BALVAL+ACT BRS N/C BONOMI	
CD	14	96D090FBA	3"BALVAL+ACT BRS N/C SPRING RET BONOMI	
AB	15	5N2ACLSS42	NPT NIP 2XCLS TBE 304SS SK40	
CD	15	5N3ACLSS42	NPT NIP 3XCLS TBE 304SS SK40	
AB	16	5N2A21AS42	NPT NIP 2X21 TBE 304SS SK40	
CD	16	5N3A12AS41	NPT NIP 3X12 TOE 304S/S SK40	
all	17	5SP2ASFSC	NPT PLUG 2" SQ CORED 304SS	
all	18	5SB2A0PSFO	NPTHEXBUSH 2X3/4 304SS 150#	
all	19	5N0P04AS42	NPT NIP 3/4X4 TBE 304SS S40	
all	19	5N0P06AS42	NPT NIP 3/4X6 TBE 304SS SK40	
all	20	5SL0PSFA	NPT ELB 90DEG 3/4 304SS 150#	
all	21	5N0P10AS42	NPT NIP 3/4X10 TBE 304SS SK40	
all	22	5SU0PSF	NPT UNION 3/4" 304SS 150#	
all	23	5N0P16AS42	NPT NIPPLE 3/4X16 TBE 304SS SK	
all	24	5N0P23AS42	NPT NIP 3/4X23 TBE 304SS SK40	
all	25	96D050A	3/4"BALLVALVE BRZ BONOMI 171N	
all	26	5N0PCLSS42	NPT NIP 3/4XCLS TBE 304SS SK40	
all	27	96J031D	3/4"PRESSREG SET 28# FEMXUN	
all	28	5S0PSFA	NPT TEE 3/4" 304SS 150#	
all	29	5N0P03AS42	NPT NIP 3/4X3 TBE 304SS SK40	
all	30	5SL0PSFK	NPT ELB 45DEG 3/4 304SS 150#	
all	31	5SB0P0CSF0	NPTHEXBUSH 3/4X1/8 304SS 150#	
all	32	30N100	PRESSGAUGE 1/8"BACKCN.0-30PSI	
all	33	96D087FSHL	1.5" BALVAL S/S LLHDL BONOMI #700LL-1.5	

Steam to Pulse Flow Tank

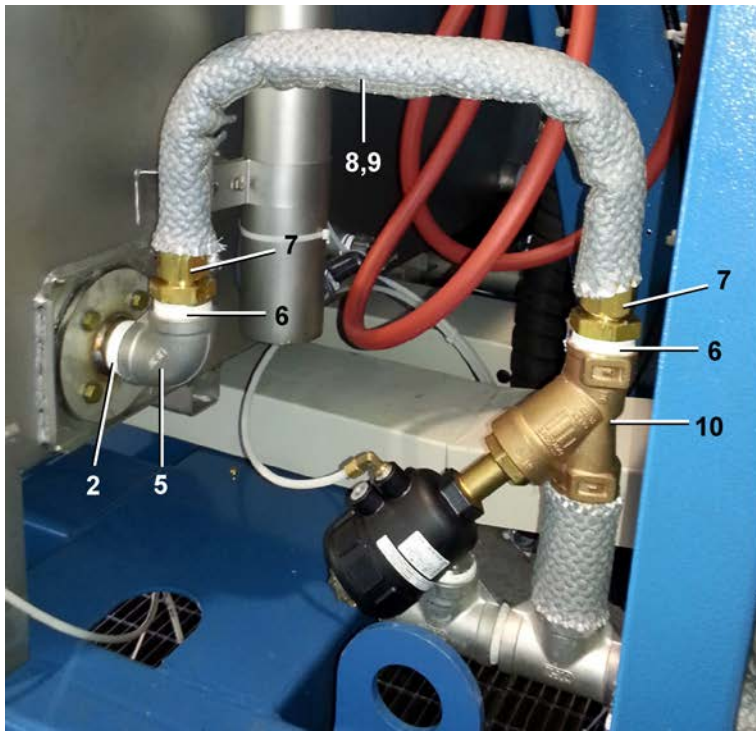

BPTPUS01.R01 0000158939 7/28/17 8:33 AM Released

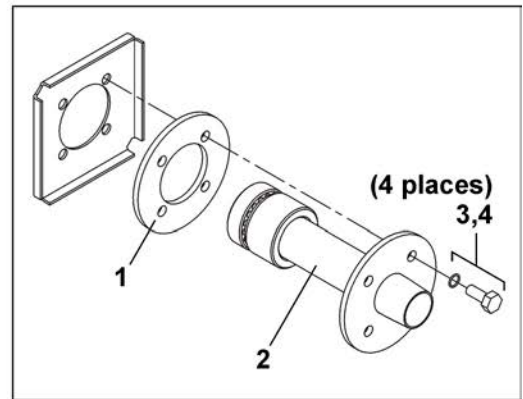

Sparger to Tank

Find the assembly for your machine and the letter shown in the "Item" column. The components for your machine will show this letter or the word "All" in the "Used In" column. The numbers shown in the "Item" column are those shown in the illustrations.

Used In	Item	Part Number	Description/Nomenclature	Comments
Components				
	1	06 20297B	GASKET=DYE CBW STEAM FLANGE	
	2	W6 20298D	WLMT=7639 STEAM SPARGER	
	3	15K095A	HEXCAPSCR 3/8-16X1" BRASS	
	4	24G030N	ROLLED WASH.379ID NYLTITE 37W	
	5	5SL1ESFA	NPT ELB 90DEG 1.25 304SS 150#	
	6	5N1ECLSS42	NPT NIP 1.25XCLS TBE 304SS S40	
	7	52ZK00S001	TUBEFITMALCN7/8X1.25#14-20FTXB	
	8	06 40095B	7/8 TUBE=STEAM DUAL TANK REUSE	
	9	98P451	INSUL.STEAM 1+1/4"OD SPEEDWRAP	
	10	96D0011E	1.25"NPTBRZ N/C STEAMVALANGBD	



Pellerin Milnor Corporation
P. O. Box 400, Kenner, LA 70063-0400

Litho in U.S.A.

Parts List—Magmeter

Find the correct assembly first, then find the needed components. The item letters (A, B, C, etc.) assigned to assemblies are referred to in the "Used In" column to identify which components belong to an assembly. The item numbers (1, 2, 3, etc.) assigned to components relate the parts list to the illustration.

Used In	Item	Part Number	Description	Comments
			-----ASSEMBLIES-----	
			-----COMPONENTS-----	
all	1	30F580	8041 BLIND UNIT MAG SENSOR	
all	2	30F580A	8025 LOWFLOW WALL-MNT TRANSMIT	
all	3	30F568	MAGMETER FITTING 316SS 1.5" S.S.TEE	

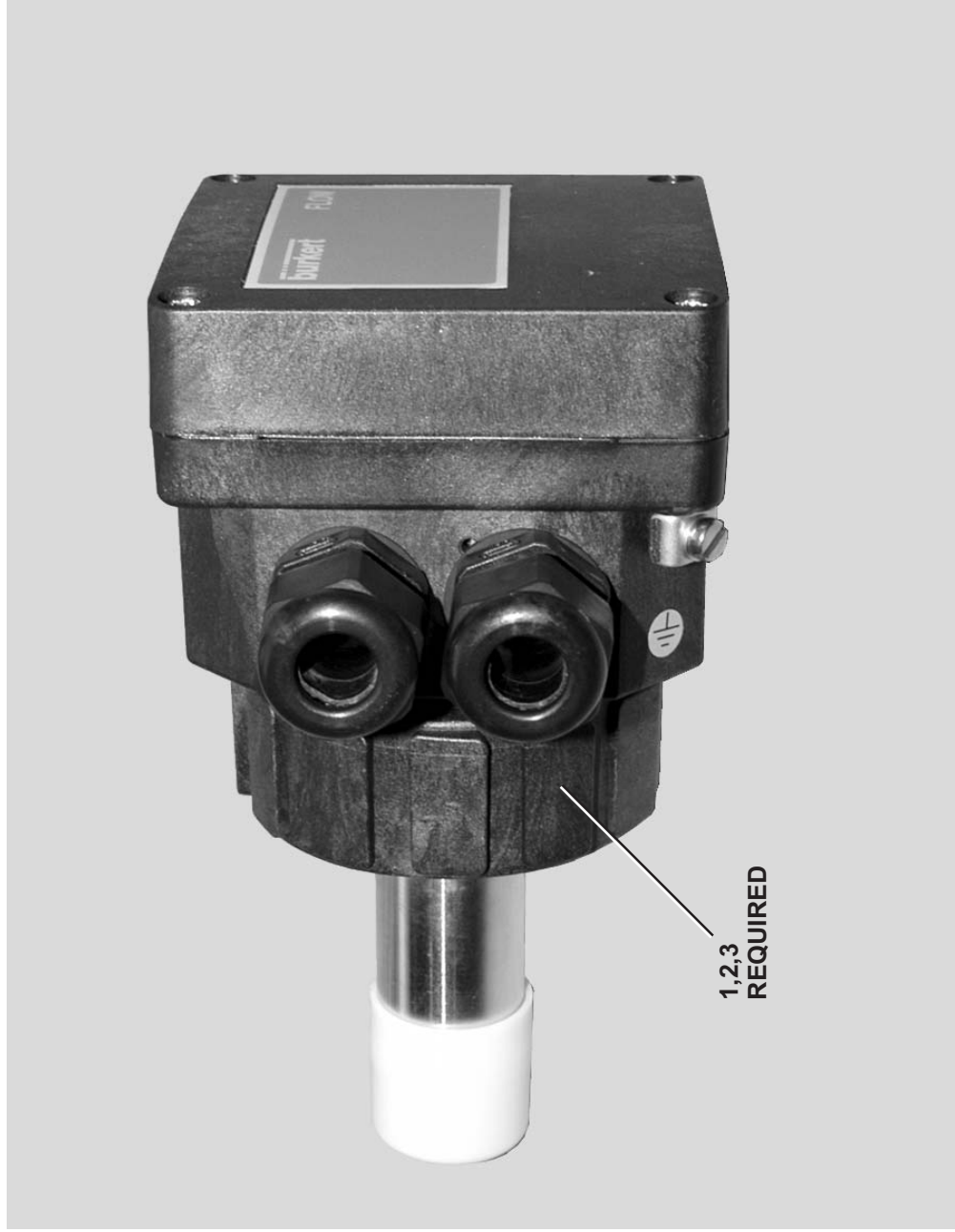

Level Switch

76028G3, 76039G3, 92048G4 Tunnels

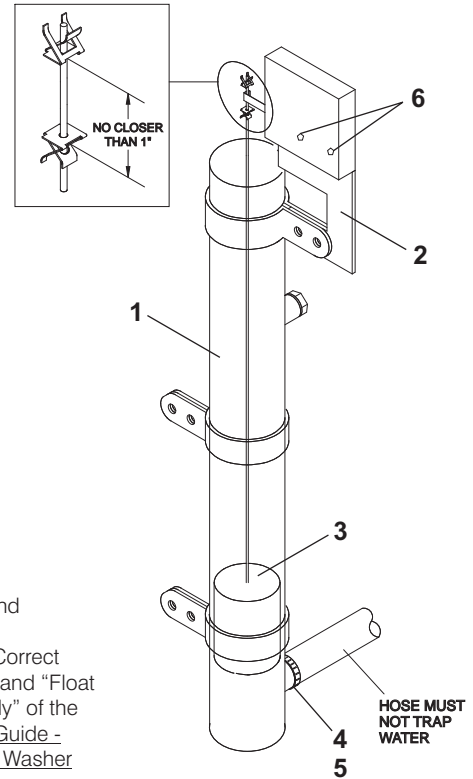

For Settings and Maintenance-
See topics: " Correct Water Levels" and "Float Level Assembly" of the [Maintenance Guide - CBW® Tunnel Washer](#)

Parts List

Find the correct assembly first, then find the needed components. The item letters (A, B, C, etc.) assigned to assemblies are referred to in the "Used In" column to identify which components belong to an assembly. The item numbers (1, 2, 3, etc.) assigned to components relate the parts list to the illustration.

Used In	Item	Part Number	Description	Comments
-----ASSEMBLIES-----				
	A	G67LS003	ADD LEVEL SW BLACK POLY	
-----COMPONENTS-----				
	1	02 14450	TUBE=FLOAT CHAMBER	
all	2	02 15097C	BRACKET LEVCONT PER PRINT	
all	3	SA 02 011	*FLOAT ASSY L=25"-STD LEVEL	
all	4	60E013	TYGON TUBING 1"IDX1.25"OD	
all	5	27A090S	HOSECLAMP 13/16-1.5"SS#64016B	
all	6	15P175	TRDCUT-F HXHD 1/4-20UNC2AX1/2	
all	7	06 70380	LEVEL TUBE MNT BRKT	
all	8	27A0625NUT	CLAMPNUT 1/4-20 W/SHORT SPRING	
all	9	02 15642S	CLAMP=3"FLOAT CHAMBER DAS	
all	10	15K039	HXCAPSCR 1/4-20UNC2AX3/4 GR5 Z	
all	11	15U181	LOCKWASHER MEDIUM 1/4 SS18-8	
all	12	15G165	HXNUT 1/4-20UNC2BSAE ZC GR2	
all	13	ELL000MK2	WATER LEV SW ASSY: 1 UP+ 1LO	

Level Box Lid & Latches

76028G3, 76039G3, 92048G4 Tunnels



Two Latches per Lid

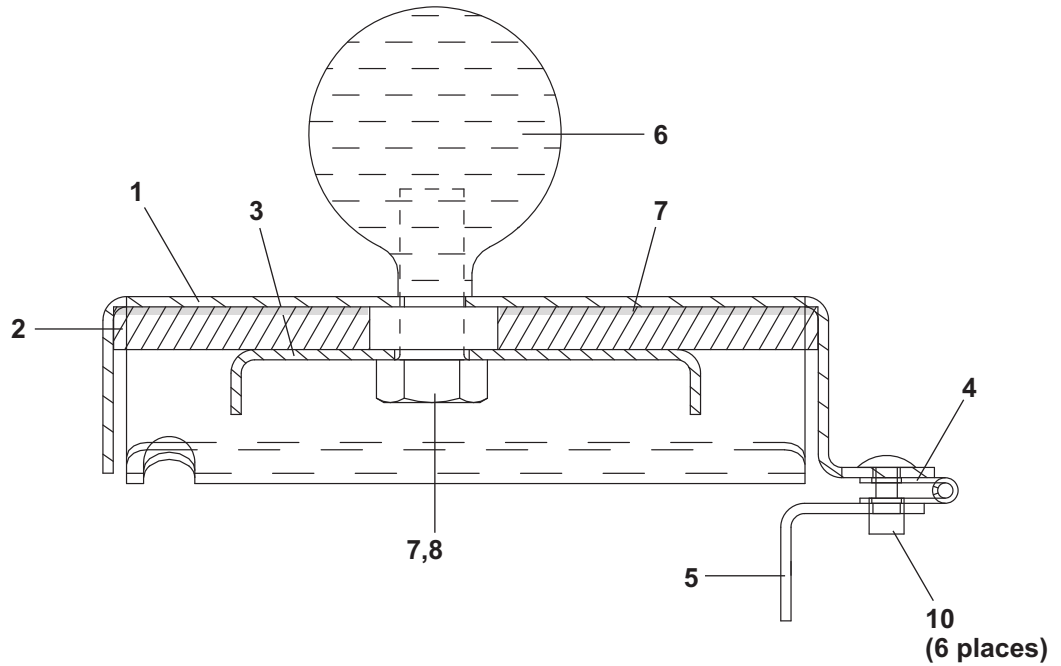

Level Box Lid & Latches

76028G3, 76039G3, 92048G4 Tunnels

Parts List				
Find the correct assembly first, then find the needed components. The item letters (A, B, C, etc.) assigned to assemblies are referred to in the "Used In" column to identify which components belong to an assembly. The item numbers (1, 2, 3, etc.) assigned to components relate the parts list to the illustration.				
Used In	Item	Part Number	Description	Comments
-----ASSEMBLIES-----				
	A	A65LL001A	7639 LEVELBOX LID ASSY W/LATCH	76028 & 76039 Tunnels
	B	A65LL002	7639=PF2 LEVELBOX LID ASSY W/LATCH	76039 PulseFlow® II(EXD)
	C	ALL63001A	9248 LEVELBOX LID ASSY W/LATCH	92048 Tunnels
-----COMPONENTS-----				
A	1	06 50135	7639 LEVELBOX LID W/LATCH	
B	1	06 50130	7639=PF2 LEVELBOX LID W/LATCH	
C	1	06 30110	9248 LEVEL BOX LID COVER W/LATCH	
A	2	06 50105	7639=LEVELBOX LID GASKET	
B	2	06 50132	7639=PF2 LEVELBOX LID GASKET	
C	2	06 30104	9248 LEVEL BOX LID GASKET	
A	3	06 50117	7639 LVL BOX GASKET SUPPT	
B	3	06 50131	7639 PF2 LVL BOX GASKET SUPPORT	
C	3	06 30114	9248 LEVEL BOX GASKET SPPT	
all	4	06 50104	7639=SOAP CHUTE HINGE	
AB	5	06 50103	7639=BRACKET=SOAP CHUTE HNGE	
C	5	06 50110	9248=BRKT=SOAPCHUTE HINGE	
all	6	12P100	BALLKNOB RD PLASTIC DAVIES#45H	
all	7	15K086A	HEXCAPSCR 3/8-24 UNFX3/4 SS18-	
all	8	15U245	FLTWASH 3/8 STD COMM 18-8 SS	
all	9	20C018	ADHESIVE-3M #1357-QT CN	
all	10	15J004	TUBULAR RIVET TRS#40988 3/16"	
all	11	27A009C	LATCH-ADJUSTABLE 304 S/S	
all	12	15N117	RDMACSCR 10-24UNC2X3/8SS18-8	
all	13	15G126	HXLOCKNUT NYLON 10-24 UNC SS N	
all	14	06 70008W	LEVEL BOX LATCH MNT	

Level Box & Flow Options

92048G4 PulseFlow® Tunnels, 76039G3 PulseFlow®II(EXD) Tunnels

BMP110073/2023103A
(1 / 3)



Pellerin Milnor Corporation
P. O. Box 400, Kenner, LA 70063-0400

Litho in U.S.A.

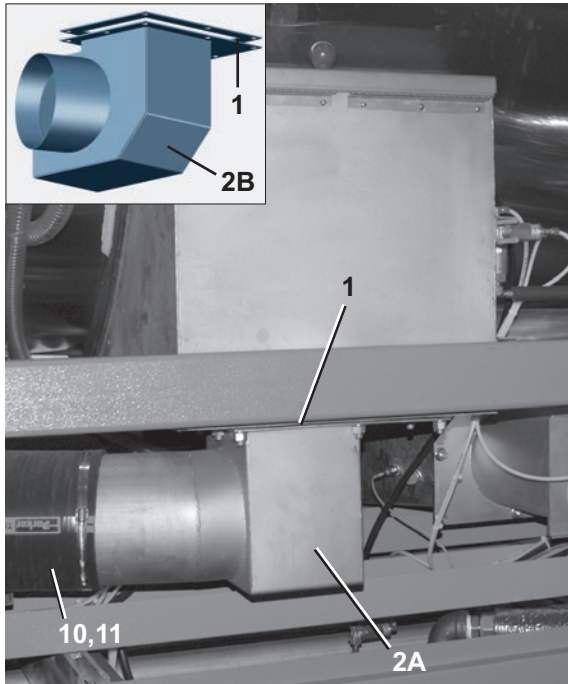

Flow to Next Module (00A,00B)

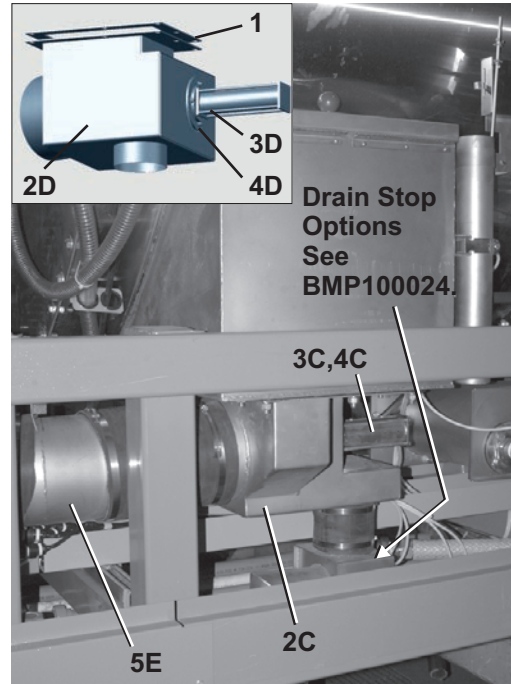

Flow to Next Module or Sewer

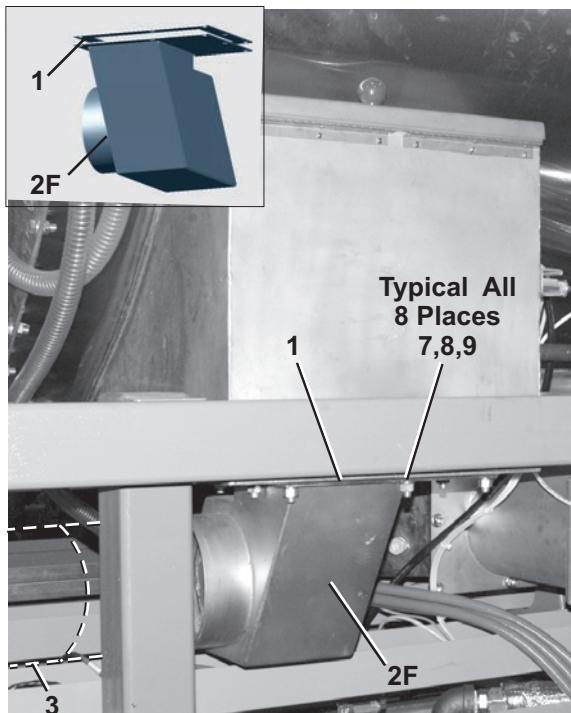

Flow to Load Offset

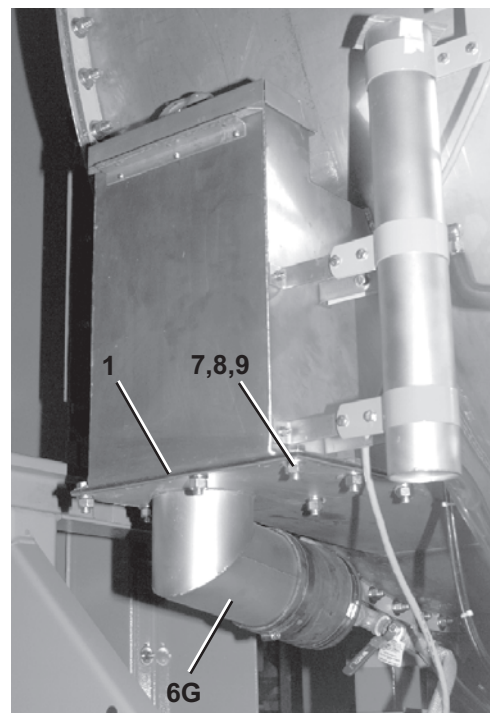

Flow to Sewer

Level Box & Flow Options

92048G4 PulseFlow® Tunnels, 76039G3 PulseFlow®II(EXD) Tunnels

BMP110073/2023103A
(2 / 3)



Pellerin Milnor Corporation
P. O. Box 400, Kenner, LA 70063-0400

Litho in U.S.A.

See BMP000079.

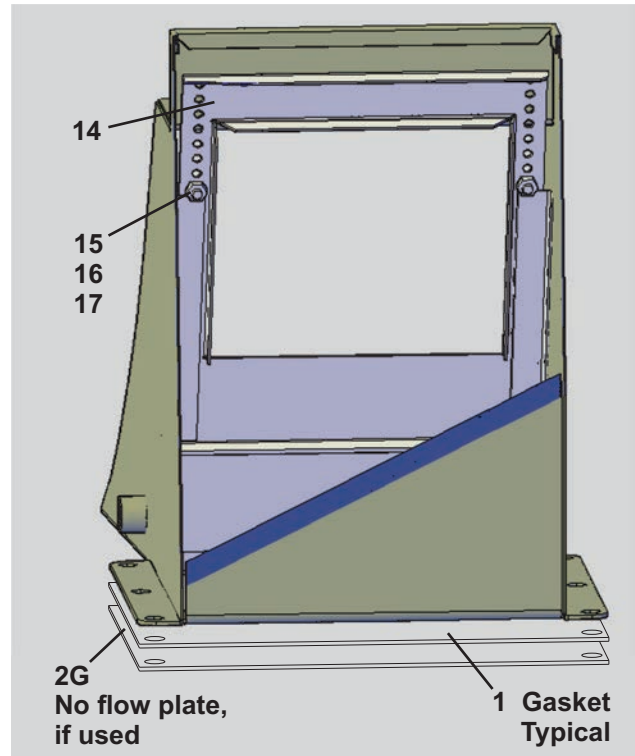
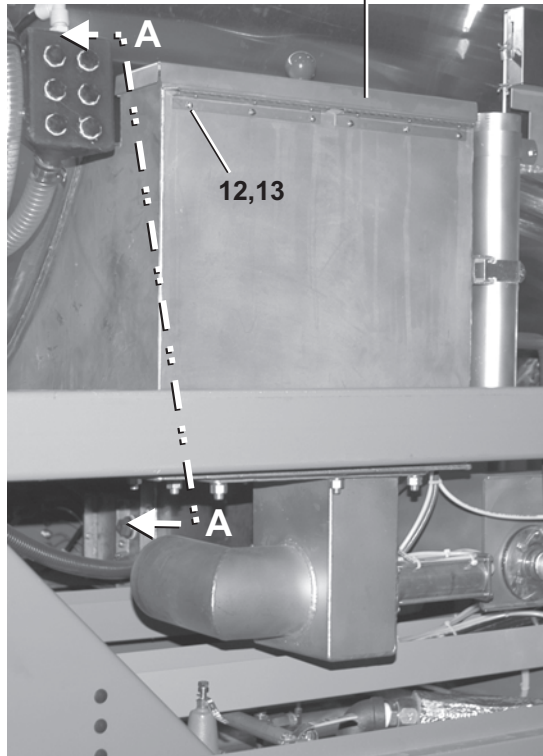

Level Box Adjusting Plate
Section A-A

Level Box & Flow Options

92048G4 PulseFlow® Tunnels, 76039G3 PulseFlow®II(EXD) Tunnels

BMP110073/2023103A
(3 / 3)



Pellerin Milnor Corporation
P. O. Box 400, Kenner, LA 70063-0400

Litho in U.S.A.

Parts List—Level Box & Flow Options

Find the correct assembly first, then find the needed components. The item letters (A, B, C, etc.) assigned to assemblies are referred to in the "Used In" column to identify which components belong to an assembly. The item numbers (1, 2, 3, etc.) assigned to components relate the parts list to the illustration.

Used In	Item	Part Number	Description	Comments
-----ASSEMBLIES-----				
	A	GLB63001	9248 LEVELBOX FLO NEXT MOD INS	92048 Tunnels
	B	G67LB001A	INST=LEVEL BOX FLOTONEXT MOD PF2	76039 PFII/EXD Tunnels
	C	GLB63002	INST=9248 FLOWNOT @ LOAD	92048 Tunnels
	D	G66FN002A	INST=7639 PF2 FLOWNOT @LOAD	76039 PFII/EXD Tunnels
	E	GLB63003A	FLOW TO LOAD AT UNIT CONN 7639 PF2	76039 PFII/EXD Tunnels
	F	GLB63003	FLOW TO LOAD AT UNIT CONNECT	92048 Tunnels
	G	GLB63005	INST=9248 FLOW TO SEWER @LD RHT	92048 Tunnels
-----COMPONENTS-----				
all	1	06 50092	7639=FLOWNOT VLV. LEVBX GSKT	
A	2A	W6 30124	9248 FLO NEXT MOD BOX WLMT	
B	2B	W6 50200	WLMT=7639 FLOW TO NEXT MOD-PF2	
C	2C	W6 50039D	9248 FLOWNOT AT BREAK WELD	
D	2D	W6 30272	WLMT=8" FLOW/FLOWNOT	
F	2F	W6 30131	9248 FLO NEXT MOD WLMT OFFSET	
G	2G	06 40528	G3 LEVEL BOX PLATE	
C	3C	A66AC001	AIR CYLINDER	92048 Tunnels
D	3D	A65AC003	AIR CYLINDER	76039 PFII/EXD Tunnels
C	4C	02 18660A	DUMP VALVE AIR CYL GASKET	
D	4D	02 18931F	GASKET=DUMPVALVE-1/60+72WEHU	
E	5E	W6 30126	8" FLO TO NEXT MOD OFFSET PIPE	
G	6G	W6 70022	WELD=DRAIN TO SEWER	
all	7	15G234B	HEXNUT 1/2-13UNC2B BRASS	
all	8	15U310	LOKWASHER REGULAR 1/2 SS18-8	
all	9	24G032N	ROLLED WASH.500ID NYLTITE 50W	
all	10	60E328A04K	HOSE+8"IDX4+1/2"LONG -4.5	4.5" LONG
all	10	60E328A07K	HOSE+8"IDX7+1/2"LONG -7.5	7.5" LONG
all	10	60E328A10A	HOSE+8"IDX10"LONG -10	10" LONG
all	10	60E328A12A	HOSE+8"IDX12"LONG -12	12" LONG
all	10	60E328A18A	HOSE-8"1DX18"LONG -18	18" LONG
all	10	60E328A22A	HOSE+8"IDX22"LONG -22	22" LONG
all	10	60E328A32A	HOSE+8"IDX32"LONG -32	32" LONG
all	11	27A092	HOSECLAMP S.S.SCR 7+1/8-10"	
all	12	15N130	RDMACSCR 10-24UNC2A X 1/2 SS18	
all	13	15G126	HXLOCKNUT NYLON 10-24 UNC SS N	
all	14	06 30130	BAFFEL LEVEL BOX 9248 CBW	92048 Tunnels
all	14	06 50097	BAFFLE=LEVEL BOX G3 PF2	76039 PFII/EXD Tunnels
all	15	15K031	BUTSOKCAPSCR 1/4-20X1/2 SS18-8	
all	16	15U181	LOCKWASHER MEDIUM 1/4 SS18-8	
all	17	15G170	HEXNUT 1/4-20UNC2 SS18-8	

Air Cylinder Flow-Not Valve

76039PF2, 92048PF

Figure 1. Double Acting Air Cylinder

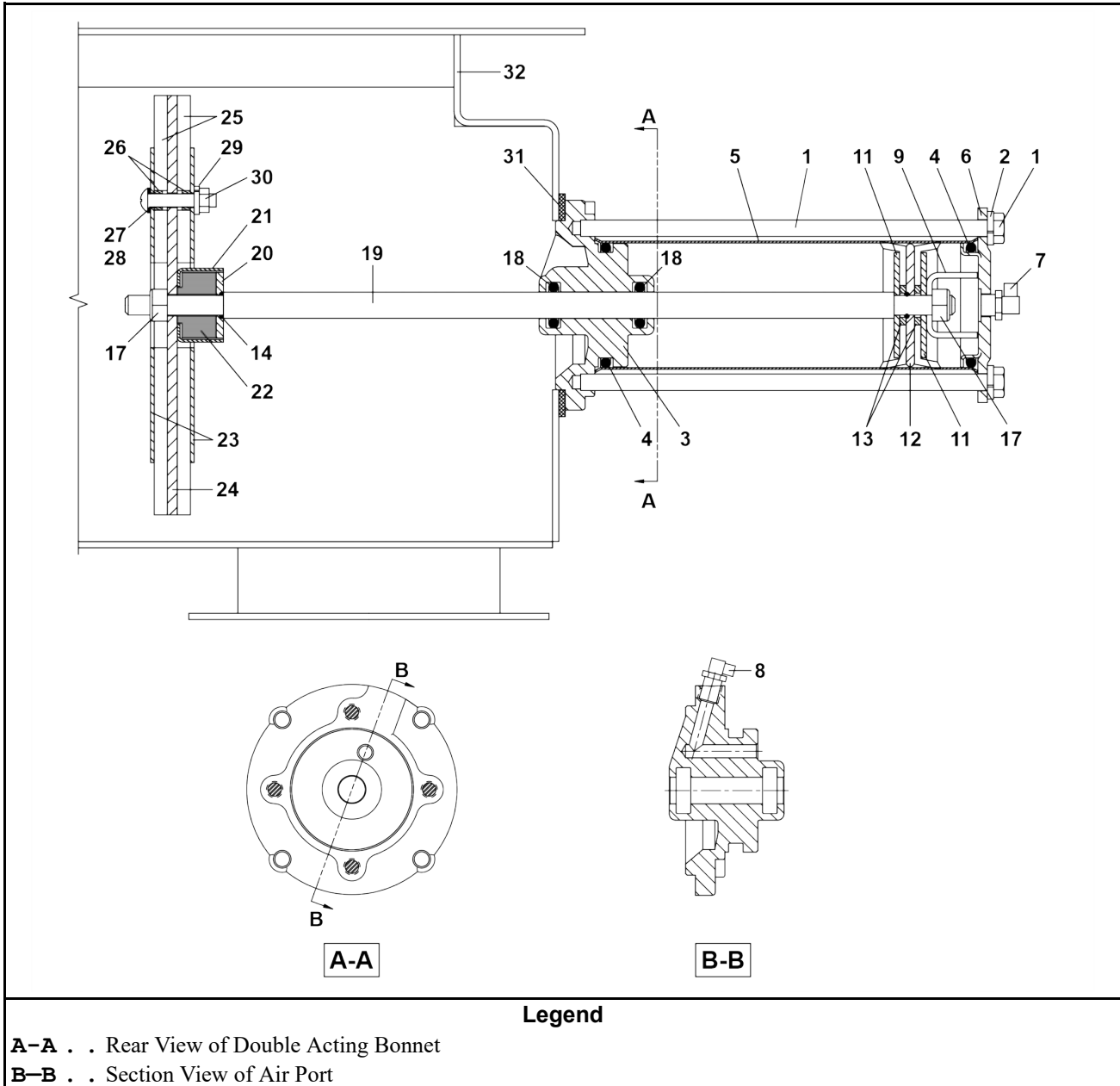

Air Cylinder Flow-Not Valve

76039PF2, 92048PF

Table 1. Parts List—Air Cylinder Flow-Not Valve

Find the assembly for your machine and the letter shown in the "Item" column. The components for your machine will show this letter or the word "all" in the "Used In" column. The numbers shown in the "Item" column are those shown in the illustrations.				
Used In	Item	Part Number	Description/Nomenclature	Comments
Reference Assemblies				
	A	ALB63006	ASSY=8" FLOW/NOT PF2	
	B	ALB63006A	ASSY=7639 PF2 FLOWNOT @LOAD	
	C	A65AC003	ASSY=9248 AIR CYL FLOW/NOT VALVE+7639 PF2	ASSEMBLY, ITEMS 1-30
Components				
all	1	02 10585	TIE BOLT=5/16-18X7.875LG SS	
all	2	15U205	LOCKWASHER MEDIUM 5/16" 18-8SS	
all	3	X6 20708A	DOUBLE ACTING VALVE BONNET	
all	4	60C132	ORING 2"IDX3/16CS BUNA70 #329	
all	5	02 02068	AIRCYL-STAINLESS=DUMP VALVE	
all	6	02 02101S	CYLINDER HEAD TAP.HOLE (SS)	
all	7	96PVQC24249	QUICK CONNECT FITTING 1/4" NPT X 1/4" TUBING 90	
all	8	96PVQC18249	QUICK CONNECT FITTING 1/8" NPT X 1/4" TUBING 90	
all	9	03 01313S	+STOP=AIRCYL W/2+11/16STR.SS	
all	10	02 02194	PISTON CUP=DUMPVALVE 2+3/8"	
all	11	02 02085	UP WASHER=2"OD=PISTON CUP	
all	12	02 02105B	2.38"ACYL BRASS PISTONCUP WSHR	
all	13	02 02185	WASHER=PISTON CUP COMP LIMIT	
all	14	60C106	ORING 5/16ID 1/16CSBUNA70#011	
all	17	15G220	NUTLOK THINHX 3/8-24 SS/NYL	
all	18	60C108	ORING 1/2IDX3/16CS BUNA70#310	
all	19	06 50082B	9248 FLOW/NOT VALVE STEM	
all	20	02 16021E	WASHER 3/8IDX1.250D DUMPVAL	
all	21	02 16021D	DUMP VALVE BUMPER RETAINER	
all	22	02 16021C	BUMPER=DUMP VALVE BONNET	
all	23	06 50083C	9248 FLOW/NOT GASKET RETAINER	
all	24	06 50084A	9248 FLOW NOT CUP	
all	25	06 50083B	9248 FLOW/NOT GASKET	
all	26	27B260156S	SPCRSLD.26ID.375OD.156L 316SS	
all	27	24G020N	ROLLED WASH.252ID NYLTITE 25W	
all	28	15N196	PHILRDMACSCR 1/4-20UNC2X1+1/4S	
all	29	15U181	LOCKWASHER MEDIUM 1/4 SS18-8	
all	30	15G164	HX THIN LOCKNUT NYL1/4-20 SS	
all	31	02 18931F	GASKET=DUMPVALVE-1/60+72WEHU	
all	32	W6 30272	WLMT=8" FLOW/FLOWNOT	

Drain Stops

76028 & 76039 G3 Tunnels, 92048 G4 Tunnels



Pellerin Milnor Corporation
P. O. Box 400, Kenner, LA 70063-0400

BMP100024/2011494B
(Sheet 1 of 1)

Litho in U.S.A.

Parts List—Drain Stops
Find the correct assembly first, then find the needed components. The item letters (A, B, C, etc.) assigned to assemblies are referred to in the "Used In" column to identify which components belong to an assembly. The item numbers (1, 2, 3, etc.) assigned to components relate the parts list to the illustration.

Used In	Item	Part Number	Description	Comments
			-----ASSEMBLIES-----	
A		G64DV005	INST=DRAIN/STOP WEIR TO SEWER	
AA		A64DV005	ASSY=DRAIN/STOP WEIR TO SEWER	
B		G64DV006	INST=DRAIN/STOP WEIR TO FLOWSP	
BB		A64DV006	ASSY=DRAIN/STOP WEIR TO FLOWSP	
C		G64DV007	INST=DRAIN/STOP F/N TO SEWER	
CC		A64DV007	ASSY=DRAIN/STOP F/N TO SEWER	
			-----COMPONENTS-----	
all	1	06 50092	7639=FLOWNOT VLV. LEVBX GSKT	
AA	2	W6 70021A	WLMT=DRAIN/WEIR TO SEWER	
BB	2	W6 70021	WLMT=DRAIN/WEIR TO SPLITTER	
CC	2	W6 70020	WLMT=DRAIN STOP F/N TO SEWER	
all	3	AVD48701	4"DUMP BONNET&AIRCYL DBL-ACT	
all	4	15G206B	HEXNUT 3/8-16UNC2 BRASS	
all	5	15U260	LOCKWASHER MEDIUM 3/8 SS18-8	
all	6	60E312A75	HOSE 5"IDX7.5"LG GATES75W4175E	
all	7	27A077D	T-BOLT HOSECLAMP 5.31-5.62"SS	

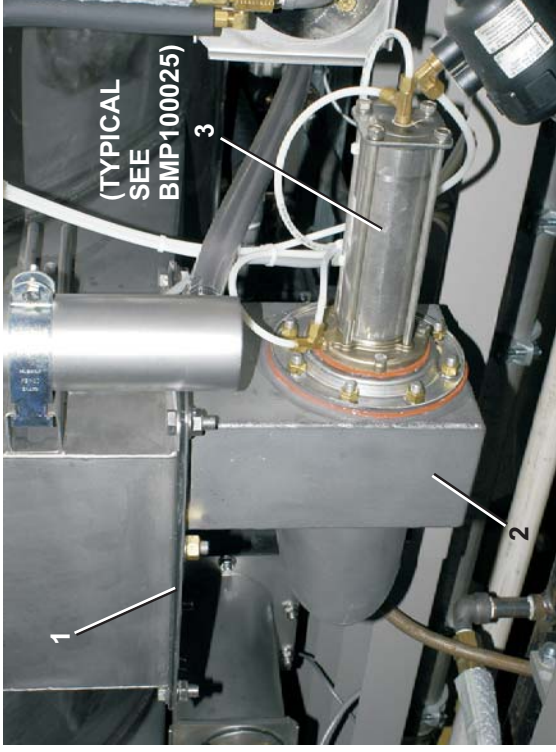

(A) Drain Stop: Flow to Sewer



(B) Drain Stop: Flow to Flow Splitter



(C) Drain Stop: Flow Not to Sewer

Drain Stop Bonnet, 4" Double Acting

76028G3, 76039G3, 9248G4

BMP100025/2010203B
(Sheet 1 of 1)



Pellerin Milnor Corporation
P. O. Box 400, Kenner, LA 70063-0400

Litho in U.S.A.

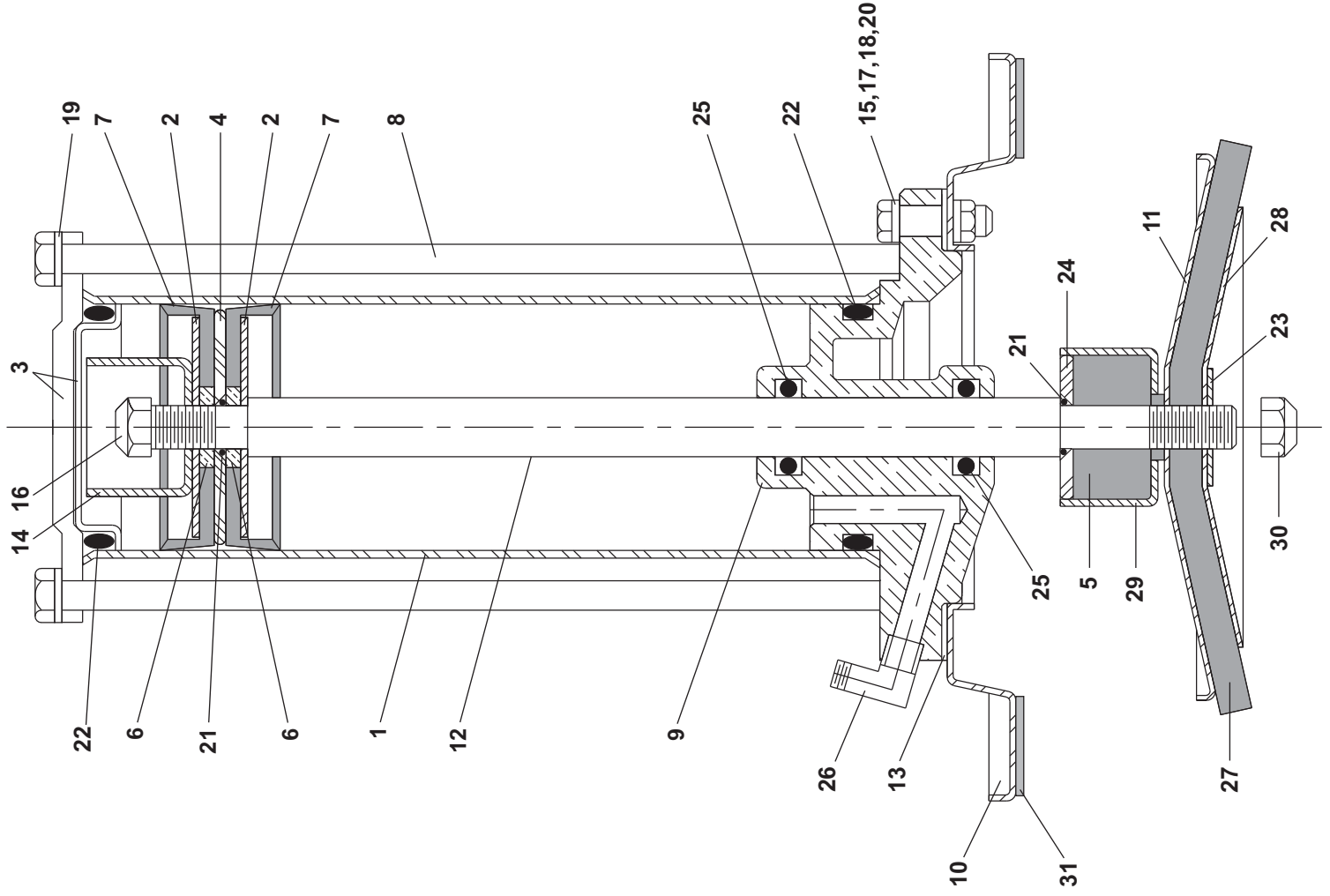

Parts List—Drain Stop Bonnet, 4" Double Acting

Find the correct assembly first, then find the needed components. The item letters (A, B, C, etc.) assigned to assemblies are referred to in the "Used In" column to identify which components belong to an assembly. The item numbers (1, 2, 3, etc.) assigned to components relate the parts list to the illustration.

Used In	Item	Part Number	Description	Comments
	A	AVD48701	4"DUMP BONNET&AIRCYL DBL-ACT	
			-----ASSEMBLIES-----	
			-----COMPONENTS-----	
All	1	02 02068	AIRCYL-STAINLESS=DUMP VALVE	
all	2	02 02085	UP WASHER=2"OD=PISTON CUP	
all	3	02 02101S	CYLINDER HEAD TAPHOLE (SS)	
all	4	02 02105B	2.38"ACYL BRASS PISTONCUP WSHR	
all	5	02 16021H	BUMPER=DMPVAL BONT RED SILC	
all	6	02 02185	WASHER=PISTON CUP COMP LIMIT	
all	7	02 02194	PISTON CUP=DUMPVALVE 2+3/8"	
all	8	02 10585	TIE BOLT=5/16-18X7.875LG SS	
all	9	X6 20708A	DOUBLE ACTING VALVE BONNET	
all	10	02 14447	BONNET=4"S/S DUMP VALVE	
all	11	02 14446	DISC=4"S/S DUMP VALVE	
all	12	02 16021I	DUMPVAL STEM=4"+8"316SS	
all	13	02 18932B	GASKET=DUMPVAL 1/8"RED SILIC	
all	15	15G168	SQNJUT 1/4-20UNC2 SS18-8	
all	16	15G220	NUTLOK THINX 3/8-24 SS/NYL	
all	17	15K041S	HEXCAPSCR 1/4-20UNC2AX1 SS18-8	
all	18	15U181	LOCKWASHER MEDIUM 1/4 SS18-8	
all	19	15U205	LOCKWASHER MEDIUM 5/16" 18-8SS	
all	20	24G020N	ROLLED WASH.252ID NYLTITE 25W	
all	21	60C106V	ORING 5/16IDX1/16CSVITON#011	
all	22	60C132V	ORING 2"ID3/16CS VITON75 #329	
all	23	15U245	FLTWASH 3/8 STD COMM 18-8 SS	
all	24	02 16021E	WASHER 3/8IDX1.250D DUMPVAL	
all	25	60C108V	ORING 1/2IDX3/16CS VITON #310	
all	26	53A031B	BODY-EL90MALE.25X1/8 #269C-42B	
all	27	02 11740D	SEAT=4"S/S VENT=RED SILICONE	
all	28	02 14446B	DISC=4"S/S DV=VENT	
all	29	02 16021D	DUMP VALVE BUMPER RETAINER	
all	30	15G219A	LOKNUT 3/8-24 NF2 18-8 SS	
all	31	02 14447B	GASKET=BON 4"S/S DPVAL RED	

Dump Valve Installation

76032, 76028, 76039, 92048 Tunnels

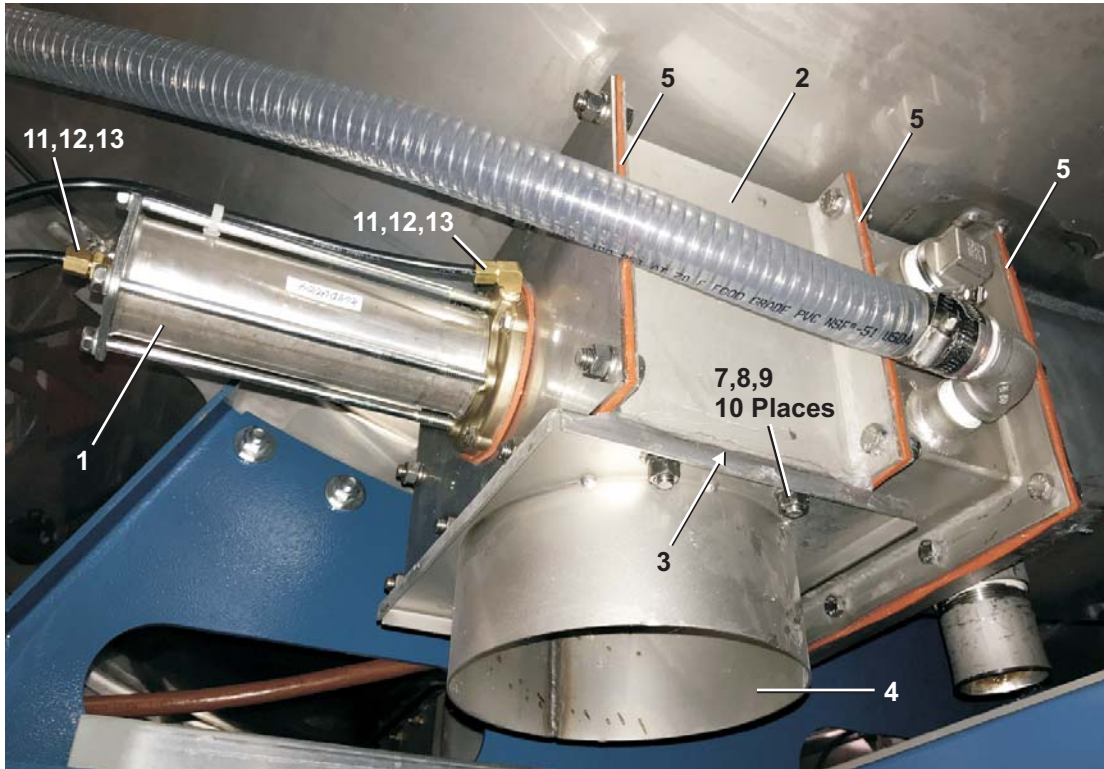

76028, 76039, 92048 Tunnels

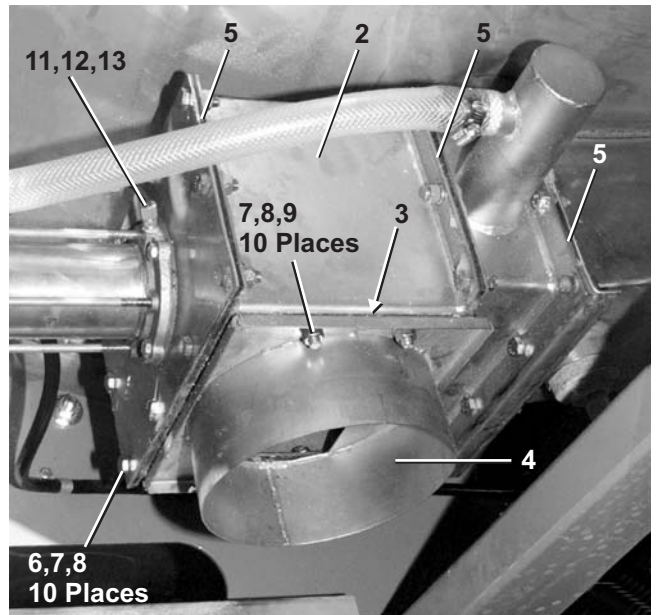
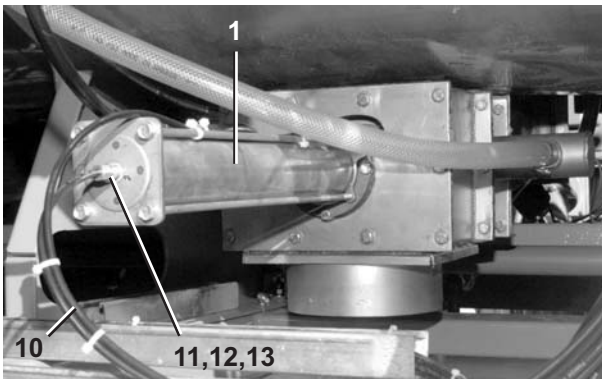

76032 Tunnels

Dump Valve Installation

76032, 76028, 76039, 92048 Tunnels

Parts List				
Find the correct assembly first, then find the needed components. The item letters (A, B, C, etc.) assigned to assemblies are referred to in the "Used In" column to identify which components belong to an assembly. The item numbers (1, 2, 3, etc.) assigned to components relate the parts list to the illustration.				
Used In	Item	Part Number	Description	Comments
-----ASSEMBLIES-----				
	A	G64DV001A	N/C 4+1/2X8 DUMP VALVE ASSY	76032 G1 NORMALLY CLOSED
	B	G64DV004	8"DUMPVAL NC SHORT G3	76028G3, 76039G3 & 92048G4 TUNNELS NORMALLY CLOSED- SHORT
-----COMPONENTS-----				
A	1	A64AC001A	N/C DUMP VAL AIR CYL 4+1/2X8	
B	1	A64DV004	BONNET DUMPVAL NC G3	
A	2	W6 40055	*DUMP VALVE BODY WLDT 4+1/2X8	
B	2	W6 40055A	DUMP VALVE WLMT SHORT G3CBW	
A	3	06 40069F	DYE DUMPVALVE ADAPT GASKET G1	
B	3	06 40069J	DUMPVAL ADAPT GASKET G3	
A	4	W6 40076	*STRAIGHT DUMP V.ADAPT WLMT	
B	4	W6 40072	WLMT=DUMP VALVE HOSE CONN ADAPT	
A	5	06 40069E	4-1/2X8 DYE DUMPVALVE GASKET	
B	5	06 40069K	4+1/2 X 8 DUMP VALVE GASKET RED SILICONE	
all	6	15K096	HEXCAPSCR 3/8-16UNC2X1SS18-8	
all	7	15U260	LOCKWASHER MEDIUM 3/8 SS18-8	
all	8	15G206	HEXNUT 3/8-16 UNC2 SS 18-8	
all	9	15K086D	HXCAPSCR 3/8-16 UNC2A X 7/8"	
all	10	15G206	HEXNUT 3/8-16 UNC2 SS 18-8	
all	11	15U260	LOCKWASHER MEDIUM 3/8 SS18-8	
all	12	60E004TE	1/4"OD X.170"ID NYL(BLK)TUBING	
all	13	53A059A	NUT 1/4"BR.HOLYOKE AND #61A-4	
all	14	53A500	SLEEVE DELRIN 1/4"OD#60PT-4	
all	15	53A501	TUBE INSERT .163"OD #63PT-4-40	

Dump Valve Bonnet
76028G3, 76039G3, & 92048G4 Tunnel

BMP000073/2011494B
 (Sheet 1 of 2)



Pellerin Milnor Corporation
 P. O. Box 400, Kenner, LA 70063-0400

Litho in U.S.A.

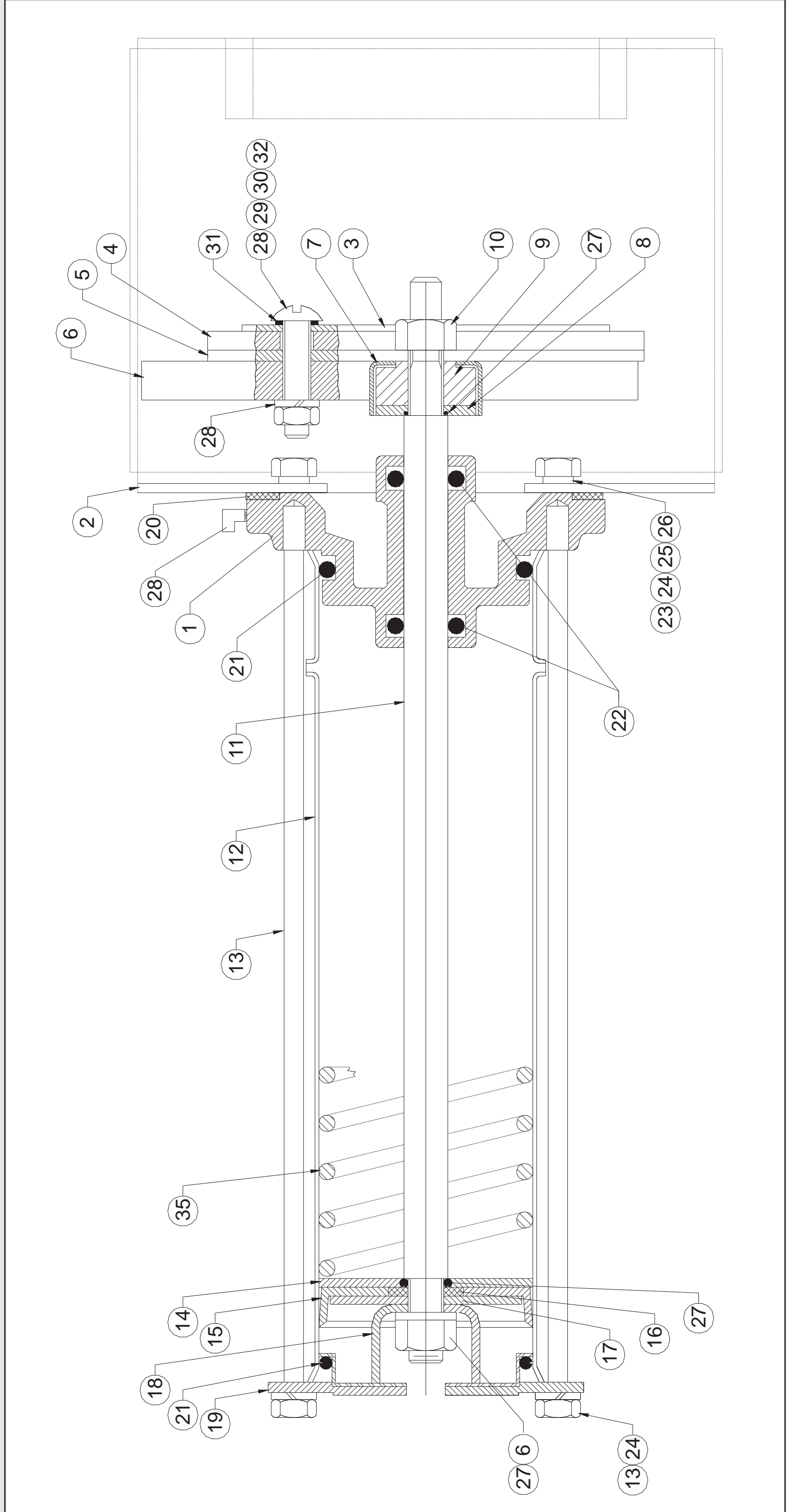



Pellerin Milnor Corporation
P. O. Box 400, Kenner, LA 70063-0400

Litho in U.S.A.

Used In	Item	Part Number	Description	Comments
	A	A64DV004	BONNET DUMPVAL NC G3	
			-----ASSEMBLIES-----	
			-----COMPONENTS-----	
all	1	X6 20708A	DOUBLE ACTING VALVE BONNET	
all	2	06 40063B	DUMP VALVE COVER PLT G3CBW	
all	3	06 40064	DUMP VALVE GASKET RETAINER	
all	4	06 40065	DUMP VALVE CUP GASKET	
all	5	06 40066	DUMP VALVE CUP	
all	6	06 40067	CUP ALIGNMENT STRIP	
all	7	02 16021D	DUMP VALVE BUMPER RETAINER	
all	8	02 16021E	WASHER 3/8IDX1.250D DUMPVAL	
all	9	02 16021C	BUMPER=DUMP VALVE BONNET	
all	10	15G220	NUTLOK THINX 3/8-24 SS/NYL	
all	11	02 16021K	DUMPVAL STEM 9" G3	
all	12	02 02068	AIRCYL-STAINLESS=DUMPVALVE	
all	13	02 10585D	TIE BOLT=5/16-18X7.875 PLTD	
all	14	02 02105B	2.38"ACYL BRASS PISCUP WASHR	
all	15	02 02194	PISTONCUP=DUMPVALVE 2+3/8"	
all	16	02 02185	WASHER=PISTON CUP COMP LIMIT	
all	17	02 02085	UP WASHER=2"OD=PISTON CUP	
all	18	03 01313	STOP=AIR CYL W/2+11/16STROKE	
all	19	02 02101	CYLHEAD W/TAPPED HOLE	
all	20	02 18931F	GASKET=DUMPVALVE-1/60+72WEHU	
all	21	60C132	ORING 2"IDX3/16CS BUNA70 #329	
all	22	60C108V	ORING 1/2IDX3/16CS VITON #310	
all	23	15K042K	BUTSOKCAPSCR 1/4-20UNCX1+1/4 S	

Used In	Item	Part Number	Description	Comments
all	24	15U210	LOKWASHER MEDIUM 5/16 ZINCPL	
all	25	15G168	SQ Nut 1/4-20UNC2 SS18-8	
all	26	24G020N	ROLLED WASH.252ID NYLTITE 25W	
A	27	60C106V	ORING 5/16IDX1/16CSVITON 11011	
B	27	60C106	ORING 5/16ID 1/16CS BUNA70#011	
all	28	53A031B	BODY-EL90MALE.25X1/8 #269C-42B	
all	29	15G164	HX THIN LOCKNUT NYL1/4-20 SS	
all	30	15U181	LOKWASHER MEDIUM 1/4 SS18-8	
all	31	15N196S	RDMACHSCR 1/4-20UNC2 X 1-1/2 S	
all	32	24G020N	ROLLED WASH.252ID NYLTITE 25W	
all	33	53A031	MALE90ELL 1/4X1/8 COMPFIT WH#6	
all	34	15U205	LOKWASHER MEDIUM 5/16" 18-8SS	
all	35	03 06429	SPRING=2.11ODX6.5FL 64#/"	

Temperature Probe

76039G3 Tunnels

BMP110077/2020355A
(1 / 1)



Pellerin Milnor Corporation
P. O. Box 400, Kenner, LA 70063-0400

Litho in U.S.A.

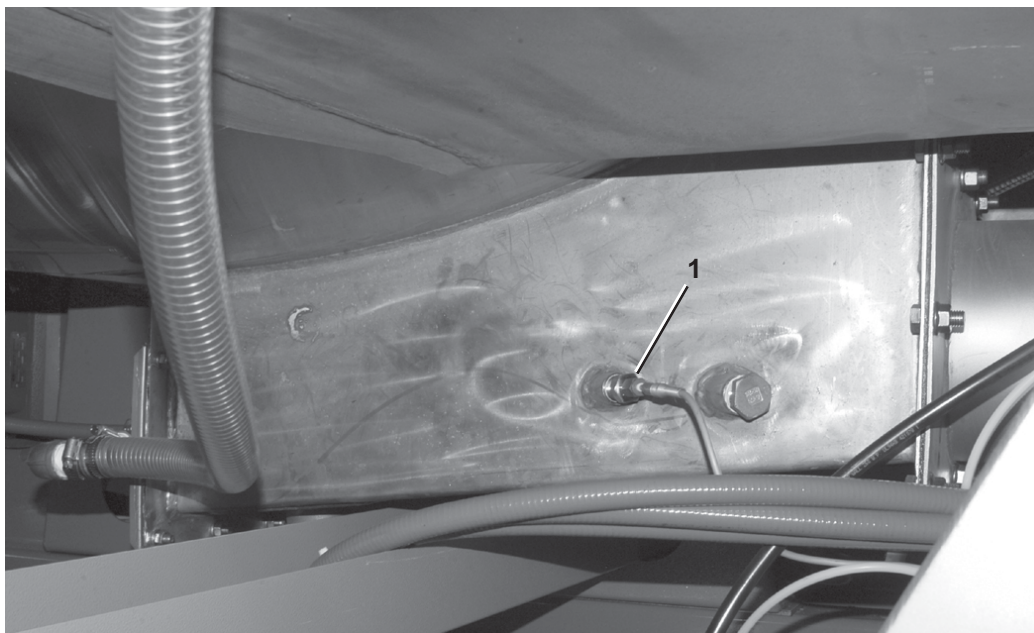

Parts List—Temperature Probe

Find the correct assembly first, then find the needed components. The item letters (A, B, C, etc.) assigned to assemblies are referred to in the "Used In" column to identify which components belong to an assembly. The item numbers (1, 2, 3, etc.) assigned to components relate the parts list to the illustration.

Used In	Item	Part Number	Description	Comments
-----COMPONENTS-----				
all	1	30R0043PSA	TEMPERATURE PROBE ASSY=S/S	

Steam Components

92048G4 Tunnel

BMP110074/2024444A
(1 / 5)



Pellerin Milnor Corporation
P. O. Box 400, Kenner, LA 70063-0400

Litho in U.S.A.

(This drawing shows steam sparger design used prior to 10/30/2024.)

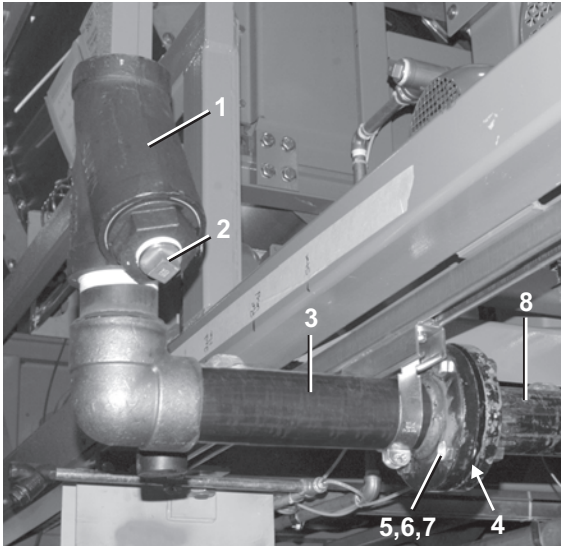

Inlet Piping

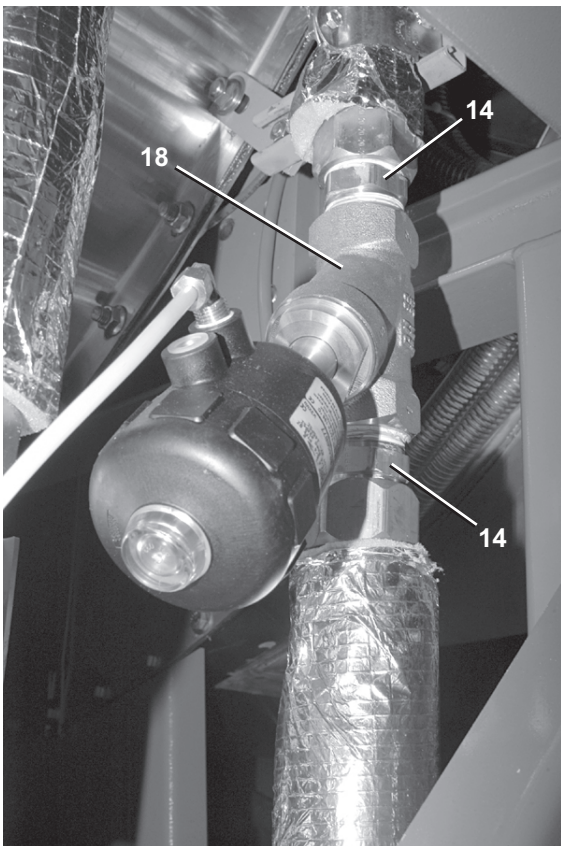
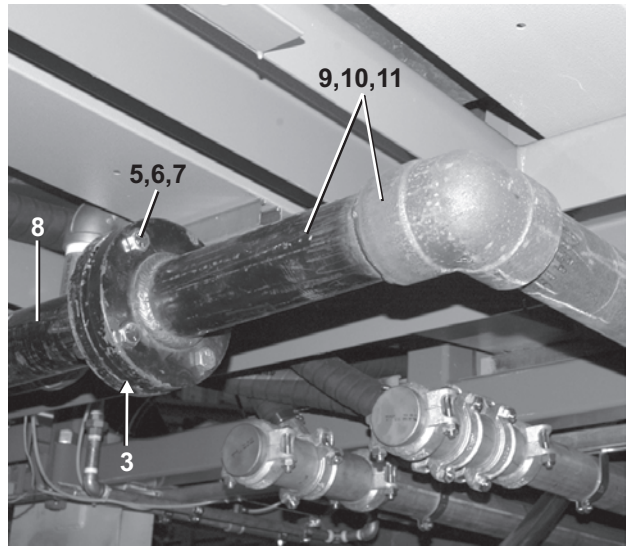

Steam Valve Assembly

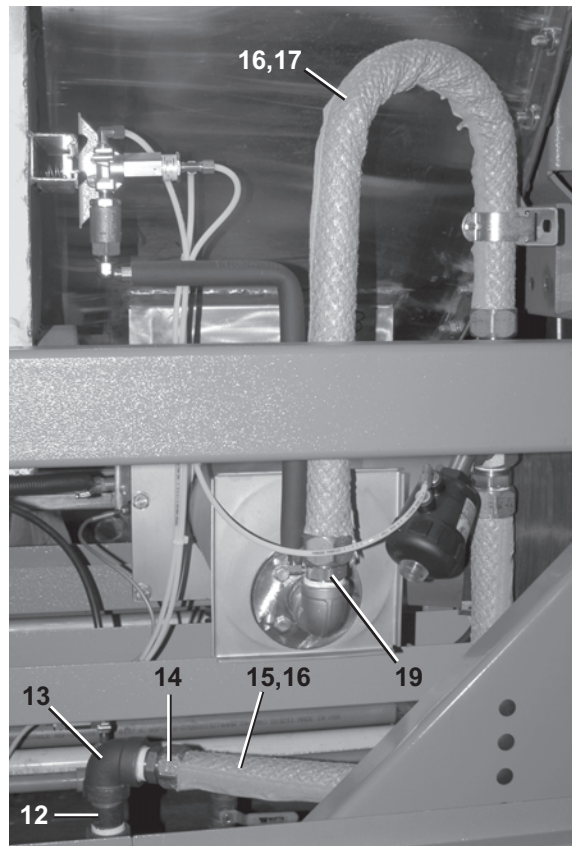

Steam Components

92048G4 Tunnel

BMP110074/2024444A
(2 / 5)



Pellerin Milnor Corporation
P. O. Box 400, Kenner, LA 70063-0400

Litho in U.S.A.

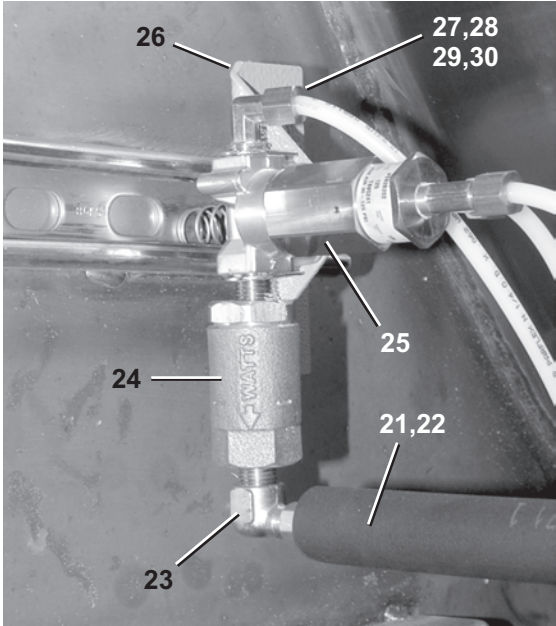

Asperator Assembly

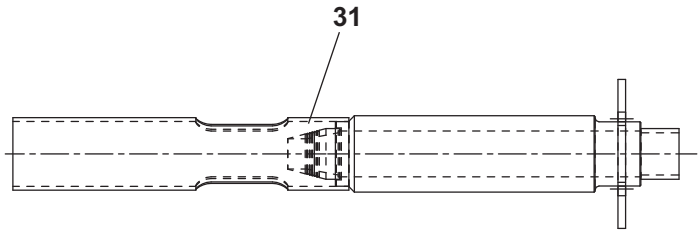

Detail: Steam Sparger

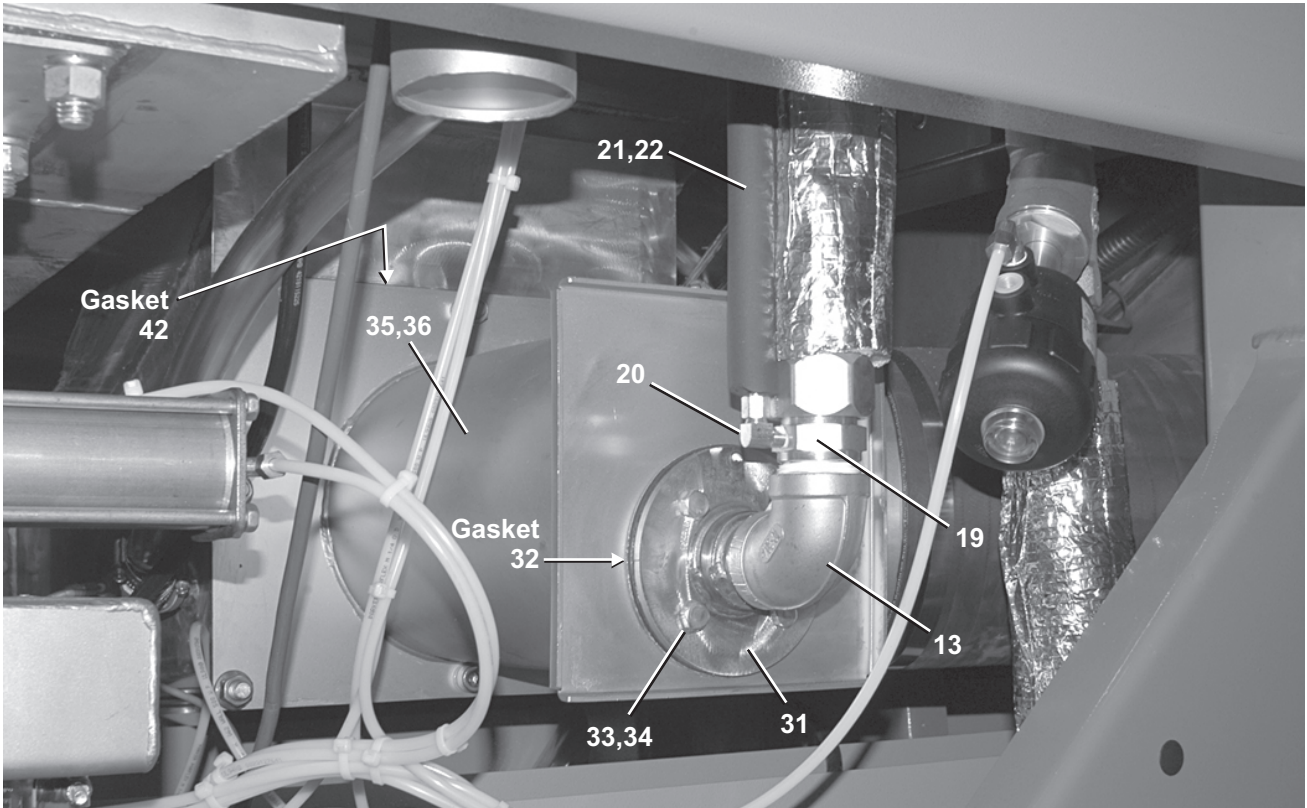

Steam Sparger Tube

Steam Components

92048G4 Tunnel

BMP110074/2024444A
(3 / 5)



Pellerin Milnor Corporation
P. O. Box 400, Kenner, LA 70063-0400

Litho in U.S.A.

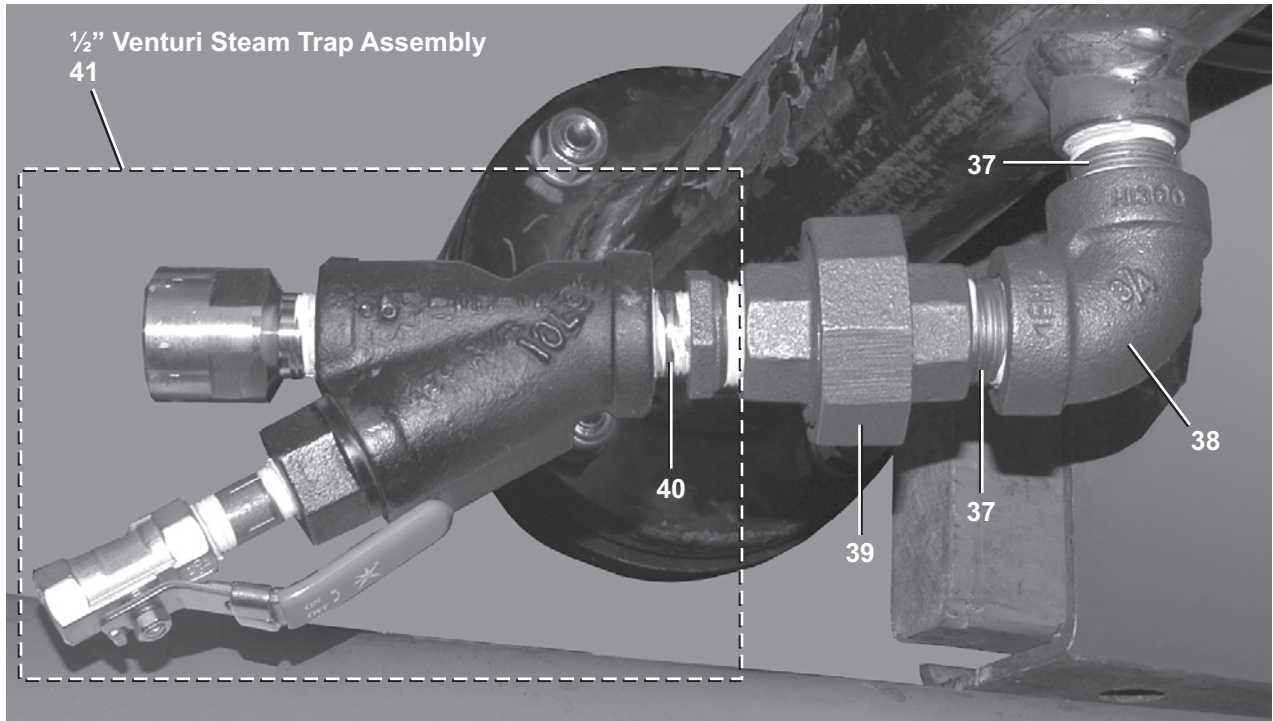

Steam Trap Installation - Last Module

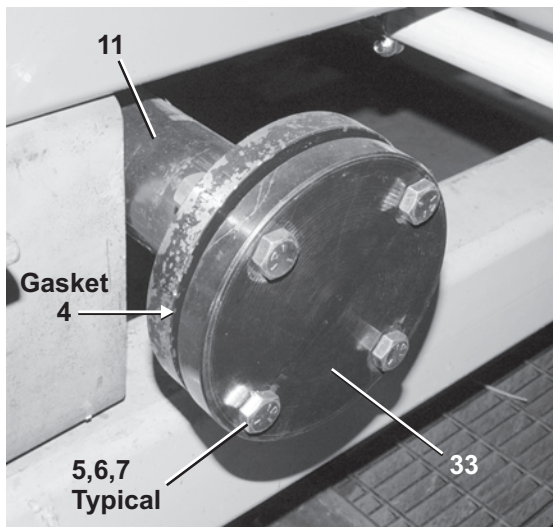

Steam Manifold - Last Module



Pellerin Milnor Corporation
P. O. Box 400, Kenner, LA 70063-0400

Litho in U.S.A.

Parts List—Steam Components

Find the correct assembly first, then find the needed components. The item letters (A, B, C, etc.) assigned to assemblies are referred to in the "Used In" column to identify which components belong to an assembly. The item numbers (1, 2, 3, etc.) assigned to components relate the parts list to the illustration.

Used In	Item	Part Number	Description	Comments
-----ASSEMBLIES-----				
	A	GSV63005	9248 3" STEAM INLET ASSY	CAST IRON
	B	GSV63005A	9248 3" STEAM INLET ASSY S/S	STAINLESS
	C	GSV63001A	MODULE 1 STEAM HEADER LEFT	CAST IRON
	D	GSV63001D	MODULE 1 STEAM HEADER LEFT S/S	STAINLESS
	E	GSV63001	STM INLET+MOD1 HEADER RIGHT	CAST IRON
	F	GSV63001B	STM INLET+MOD1 HEADER RT S/S	STAINLESS
	G	GSV63008	9248 STEAM INLET	CAST IRON
	H	GSV63008A	9248 STEAM INLET S/S	STAINLESS
	J	GSV63006	9248 STEAM TRAP ASSY	
-----COMPONENTS-----				
all	1	51T066	Y-STRAINER 3" NPT CAST IRON	
all	2	5SP1ESFSS	NPT PLUG 1.25 SQ SOLID 304SS	
all	3	W6 20740C	ADPT=Y-STRAINER 3"	
all	3	W6 20740E	ADPT=STRAIN 3" S/S	
all	4	51KE2ANASB	3" SPIRAL GASKET #FGCCG-1JG	
all	5	15K225	HEXCAPSCR 5/8-11X2+1/2	
all	6	15U315	LOKWASHER MEDIUM 5/8 ZINCPL	
all	7	15G238	HXNUT 5/8-11UNC2B SAE ZINC GR2	
A	8	W6 30100B	STEAM INLET PIPE LF WELD	
B	8	W6 30100C	MODULE 1 STM HEADER LF SS WELD	
A	9	W6 30100A	MODULE 1 STEAM HEADER LF WELD	
C	9	W6 30100	WELD STMMFLD 1ST MOD RIGHT	
D	9	W6 30100F	WELD STMMFLD 1ST MOD RIGHT S/S	
A	10	W6 30101A	WELD STMMFLD 3 MID MODS	
B	10	W6 30101C	WELD STMMFLD 3 MID MODS S/S	
A	11	W6 30101	WELD STMMFLD 1ST/MID MOD	
B	11	W6 30101B	WELD STMMFLD 1ST/MID MOD S/S	
A	12	5N1E03AF42	NPT NIP 1.25X3 TBE BLKSTL SK40	
B	12	5N1E03AS42	NPT NIP 1.25X3 TBE 304SS SK40	
A	13	5SL1EMIA	NPT ELBOW 90DEG 1.25" BLKMAL 3	
B	13	5SL1ESFA	NPT ELB 90DEG 1.25 304SS 150#	
all	14	52ZX00S005	TUBEFITMALCN1.25#20-FTX-B	
all	15	06 30137	9248 STEAM TUBE 90 DEGREES	
all	16	98P498	INSUL.STEAM1+1/4ID X3/4"T-VBD	



Pellerin Milnor Corporation
P. O. Box 400, Kenner, LA 70063-0400

Litho in U.S.A.

Parts List—Steam Components

Find the correct assembly first, then find the needed components. The item letters (A, B, C, etc.) assigned to assemblies are referred to in the "Used In" column to identify which components belong to an assembly. The item numbers (1, 2, 3, etc.) assigned to components relate the parts list to the illustration.

Used In	Item	Part Number	Description	Comments
all	17	06 30138	1 1/4 STEAM TUBE 180 DEGREES	
all	18	96D0011E	1.25"NPTBRZ N/C STEAMVALANGBD	
all	19	52ZX00S009	TBEFTMALCN1.25#20-FTX-B 1/8NPT	
all	20	53A031B	BODY-EL90MALE.25X1/8 #269C-42B	
all	21	87Z00EX035	TUBE=1/4"ODX.035WL 316LSS*20RM	
all	22	98P505A	INSUL.1/4"IDX3/8"WALLX721TUBE	
all	23	53A016A	AIR RESTRICTER=STEAM CBW	
all	24	96DG030	CHECKVLV, 1/4"WATTS-SERIES 600	
all	25	96TBC2AA00	1/4" N/C 2WAY AIR-OP VALVE (NO COIL)	
all	26	06 40438	BRK=STEAM AIRVAL=ASPIRATOR	
all	27	53A031XB	BODY-EL90MALE.25X25 #269C-4-4B	
all	28	53A500	SLEEVE DELRIN 1/4"OD#60PT-4	
all	29	53A501	TUBE INSERT .163"OD #63PT-4-40	
all	30	53A059A	NUT 1/4"BR.HOLYOKE AND #61A-4	
all	31	ASS60007B	*ASSY=STM MIXER 1" ORF-22 LONG	
all	32	06 20297C	GASKET=CBW SPRGR INLET FLNG	
all	35	W6 30095	WLMT=SPARGER TUBE STRAIGHT	
all	36	W6 30095A	8" Y-BRANCH SPARGER TUBE WLMT	
all	37	5N0PCLSF82	NPT NIP 3/4XCLS TBE BLKSTL S80	
all	38	5SL0PMIA	NPTELB 90DEG 3/4 BLKMAL 300#	
all	39	5SU0PMI	NPT UNION 3/4" BLKMAL 300#	
all	40	5N0KCLSF42	NPT NIP 1/2XCLS TBE BLKSTL S40	
all	41	51T60B00QJ	1/2"STMTRP LPA-MILNOR-05	
All	42	06 30096	GASKET=STEAM SPARGER FLANGE	

Steam Components with No-Air Sparger

76028G3, 76039G3 Tunnels

Figure 1: Steam Inlet with 1.25" No-Air Sparger

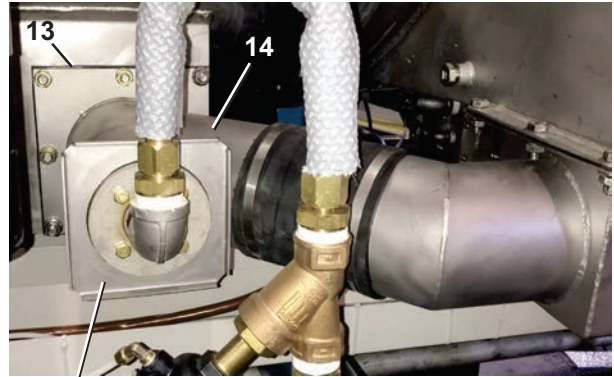
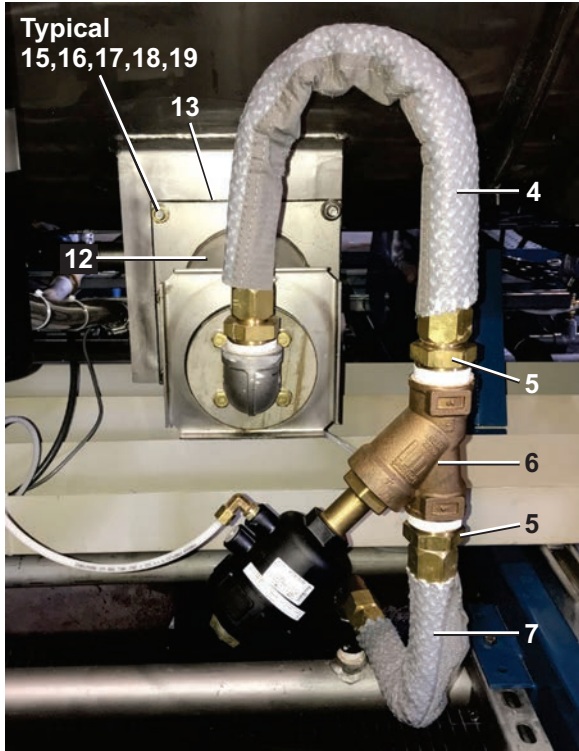

20,21
Cover here
if no steam

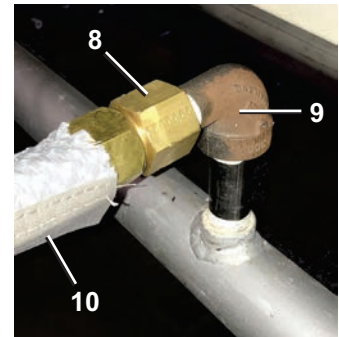

2" Manifold

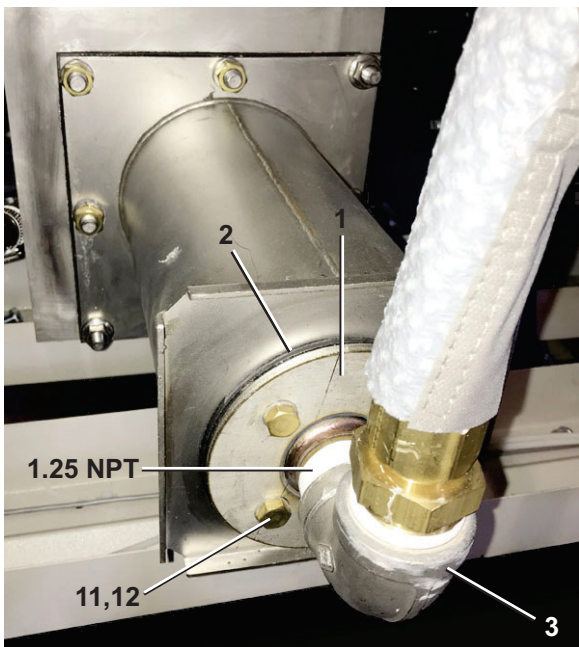

1.25" No-Air Sparger

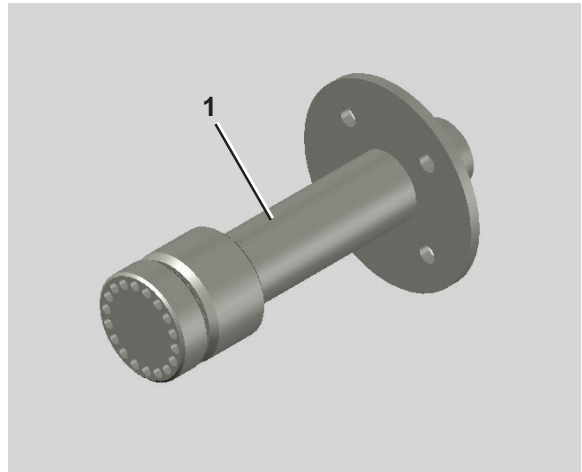

Steam Components with No-Air Sparger

76028G3, 76039G3 Tunnels

Figure 2: Steam Manifold Inlet and Steam Trap

Steam Manifold Inlet 2"

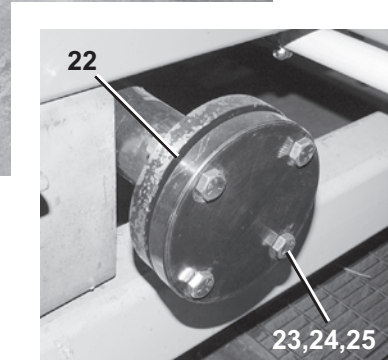
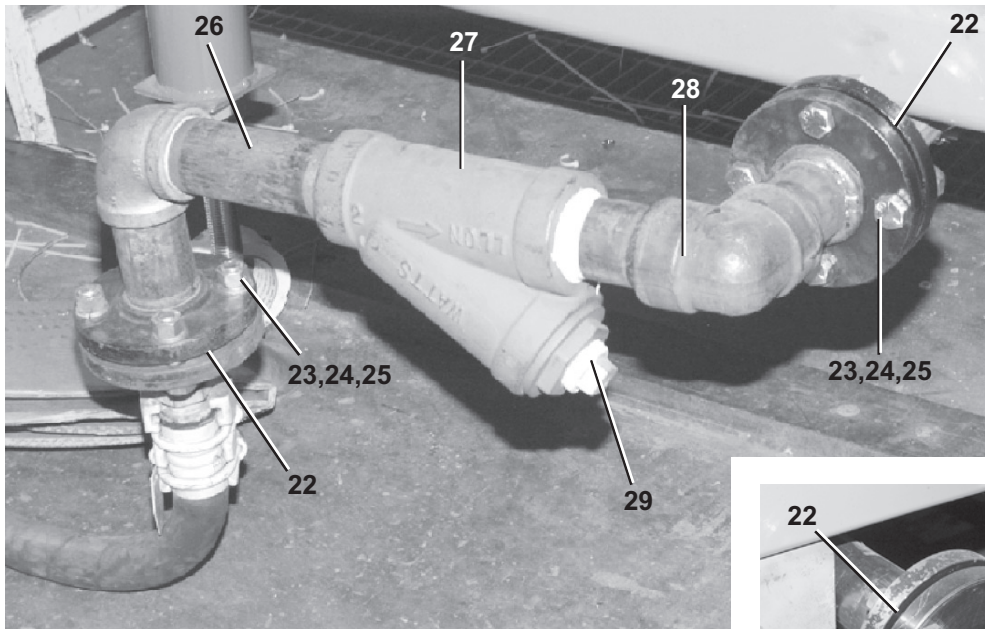

Steam Manifold - Last Module

1/2" Steam Trap Assembly (under last module)

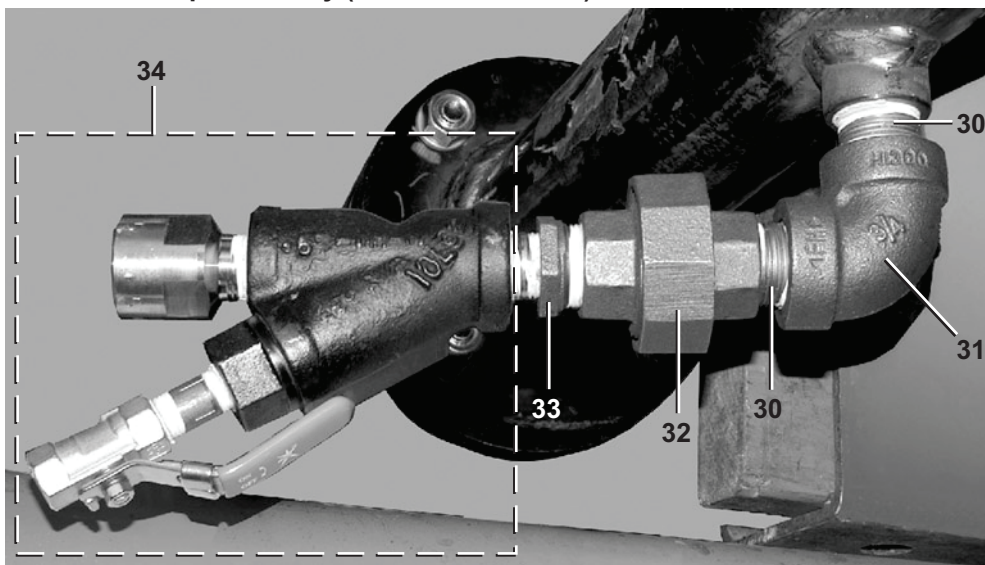

Steam Components with No-Air Sparger

76028G3, 76039G3 Tunnels

Parts List				
Find the correct assembly first, then find the needed components. The item letters (A, B, C, etc.) assigned to assemblies are referred to in the "Used In" column to identify which components belong to an assembly. The item numbers (1, 2, 3, etc.) assigned to components relate the parts list to the illustration.				
Used In	Item	Part Number	Description	Comments
-----REFERENCE ASSEMBLIES-----				
	A	G67SV001J	G3 STM INLET NON AIR STEAM SPARGER	BRASS COMPONENTS
	B	G67VS001A	INST=7639 PF2 CAP FLOWINLET W/STEAM	
	C	G67VS002	INST=PF2 STM+H2O Y-BRANCH	
	D	A67SV005	7639/28G3 STM INLET ASSY	
	E	A67SV004B	7628/39G3 STM TRAP ASSY	
	F		REFERENCE	
-----COMPONENTS-----				
	all	1	W6 20298D	WLMT=7639 STEAM SPARGER
	all	2	06 20297C	GASKET=CBW SPRGR INLET FLNG
	all	3	5SL1ESFA	NPT ELB 90DEG 1.25 304SS 150#
	all	4	06 40093D	7/8 TUBE=U-SHAPE STEAM
A	5	52ZK00S001	TUBEFITMALCN7/8X1.25 #14-20 FTX-B	
F	5	52ZK00S002	TUBEFITMLCN7/8X1.25 #14-20 FTX-SS	
all	6	96D0011E	1.25"NPTBRZ N/C STEAMVALANGLBD	
all	6	96D0011S	1.25"NPT S/S N/C STEAMVAL ANGBODY	
all	7	06 40093C	7/8 TUBE=90 DEG STEAM	
all	8	52ZL00S001	TUBEFITFEMCN7/8 X 3/4#14-GTX-B	
all	9	5SL0PFSC	NPT ELB 90DEGSTRT 3/4BLKSTL3000	
all	10	98P450	INSUL.STEAM 7/8"OD SPEEDWRAP	
A	11	15K095	HXCPSCR 3/8-16UNC2AX1 GR5 ZINC	
F	11	15K095A	HEXCAPSCR 3/8-16X1" BRASS	
all	12	24G030N	ROLLED WASH.379ID NYLTITE 37W	
all	13	06 50095	FLANGE GASKET=8" TUBE 7639 PF2	
all	14	W6 80095A	8" Y-BRANCH SPARGER TUBE WLMT-PF2	
all	15	15K153	HXCAPSCR 1/2 -13 X 1 +1/4 SS	
all	16	24G032N	ROLLED WASH.500ID NYLTITE 50W	
all	17	15U310	LOKWASHER REGULAR 1/2 SS18-8	
all	18	15G234B	HEXNUT 1/2-13UNC2B BRASS	
all	19	15G225	HEXNUT 1/2-13UNC2 SS18-8	
all	20	06 20298A	PLATE FLANGE NO STEAM	
all	21	06 20297B	GASKET=DYE CBW STEAM FLANGE	
all	22	51KE2ANASA	2" SPIRAL GASKET #FGCCG-1GG	
all	23	15K225	HEXCAPSCR 5/8-11X2+1/2	
all	24	15U315	LOKWASHER MEDIUM 5/8 ZINCPL	
all	25	15G238	HXNUT 5/8-11UNC2B SAE ZINC GR2	
A	26	W6 40442	2" MAIN STM MNFLD INLET	

Steam Components with No-Air Sparger

76028G3, 76039G3 Tunnels

Parts List

Find the correct assembly first, then find the needed components. The item letters (A, B, C, etc.) assigned to assemblies are referred to in the "Used In" column to identify which components belong to an assembly. The item numbers (1, 2, 3, etc.) assigned to components relate the parts list to the illustration.

Used In	Item	Part Number	Description	Comments
F	26	W6 40442S	2" MAIN STM INLET S/S	
all	27	51T062	Y-STRAINER 2" NPT CAST IRON	
A	28	W6 20740B	ADPT=Y-STRAINER	
F	28	W6 20740S	ADPT=Y-STRAINER S/S	
all	29	5SP1ESFSS	NPT PLUG 1.25 SQ SOLID 304SS	
all	30	5N0PCLSF82	NPT NIP 3/4XCLS TBE BLKSTL S80	
A	31	5SL0PMIA	NPTELB 90DEG 3/4 BLKMAL 300#	
F	31	5SL0KSFA	NPTELB 90DEG 1/2 304SS 150#	
all	32	5SU0PMI	NPT UNION 3/4" BLKMAL 300#	
A	33	5SB0P0KMFO	NPTHEXBUSH 3/4X1/2 BLKMAL 150#	
F	33	5SB0P0KSFO	NPTHEXBUSH 3/4X1/2 SS304 150#	
all	34	51T60B00QJ	1/2"STMTRP LPA-MILNOR-05 VENTURI	

Peristaltic Chemical Inlets

76028G3, 76039G3, 92048G4 Tunnels

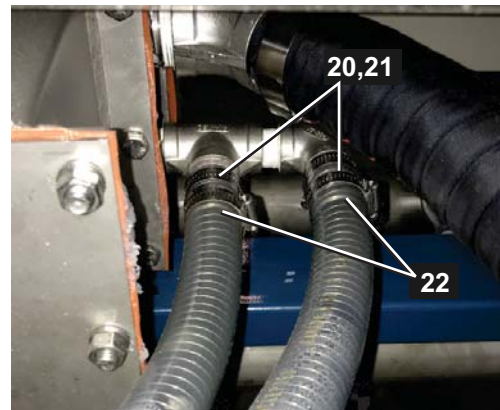
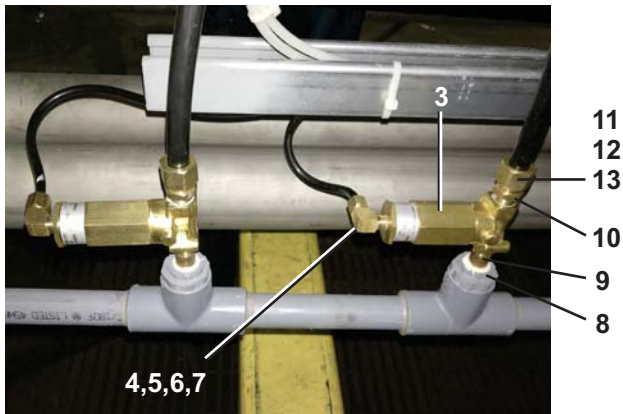
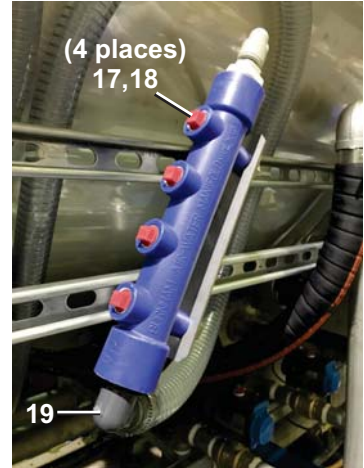

Peristaltic Chemical Inlets

76028G3, 76039G3, 92048G4 Tunnels

Parts List

Find the correct assembly first, then find the needed components. The item letters (A, B, C, etc.) assigned to assemblies are referred to in the "Used In" column to identify which components belong to an assembly. The item numbers (1, 2, 3, etc.) assigned to components relate the parts list to the illustration.

Used In	Item	Part Number	Description	Comments
-----COMPONENTS-----				
all	1	06 70196	PERISTALTIC TUBE MNT	
all	2	02 03590C	CHEM INJ MANIFOLD 4-PORT MOLDED	
all	3	96TBC2AA01	1/4" N/C 1WAY AIR-OP VALVE POLYPRO (NO COIL)	
all	4	60E004TE	1/4"OD X.170"ID NYL(BLK)TUBING	
all	5	53A059A	NUT 1/4"BR.HOLYOKE AND #61A-4	
all	6	53A500	SLEEVE DELRIN 1/4"OD#60PT-4	
all	7	53A501	TUBE INSERT .163"OD #63PT-4-40	
all	8	5KB0K0EP82	BUSHING 1/2"SOKX1/4FPT CPVCS80	
all	9	5N0ECLSBE2	NPT NIP 1/4XCLS TBE BRASS 125#	
all	10	53ACM0KEB	ASSY MALECON.5TX.25MP BRASS 68	
all	11	53A3000KB	SLEEVE 1/2"OD TUBE #60AP-8	
all	12	53A4000KB	TUBE INSERT 1/2"OD #60AE-8	
all	13	53A10SSKB	.5T COMPNUT 11/16-20 AND#61A-8	
all	14	60E005F	TUBING NYL.BLK.1/2"ODX.375ID	
all	15	53AEM9KKBC	MAL90ELSW1/2"TXM PARK#A8MES8MG	
all	16	5SB1A0KP4O	NPTHEXBUSH 1X1/2 PVC SK40	
all	17	51PB0GNA	3/8" PVDF THRD PLUG	
all	18	20C005EA	LOCTITE TREAD SEALANT #1537780	
all	19	51ET1AE02	HOSEADAPT PVC 1"X1" INSERT 90 DEG	
all	20	60E010B	TUBING,POLYWIRECLR 1"IDX1.375"	
all	21	27A090S	HOSECLAMP 13/16-1.5"SS#64016B	
all	22	5N0P02GS41	NPT NIP 3/4X2.375TOE 304SS SK4	
all	23	27A0626NUT	CLAMP NUT 3/8-16 W/SPRING	
all	24	15K096	HEXCAPSCR 3/8-16UNC2X1SS18-8	
all	25	15U260	LOCKWASHER MEDIUM 3/8 SS18-8	
all	26	15U245A	FLTWASH 25/64IDX1.25ODX3/32 S/	
all	27	15K145D	HXCAPSCR 1/2-13UNC2AX3/4 SS18-	
all	28	15U310S	FLATWASH-SS .53 X 1.37 .187T	
all	29	15U310	LOKWASHER REGULAR 1/2 SS18-8	

2

Pneumatics

2.4



Pellerin Milnor Corporation
P. O. Box 400, Kenner, LA 70063-0400

Litho in U.S.A.

Parts List—Pneumatic Shuttle Valve
Find the correct assembly first, then find the needed components. The item letters (A, B, C, etc.) assigned to assemblies are referred to in the "Used In" column to identify which components belong to an assembly. The item numbers (1, 2, 3, etc.) assigned to components relate the parts list to the illustration.

Used In	Item	Part Number	Description	Comments
all	1	96N0011H	SHUTTLVLV 1/4" 4WAY MECHSPRING	

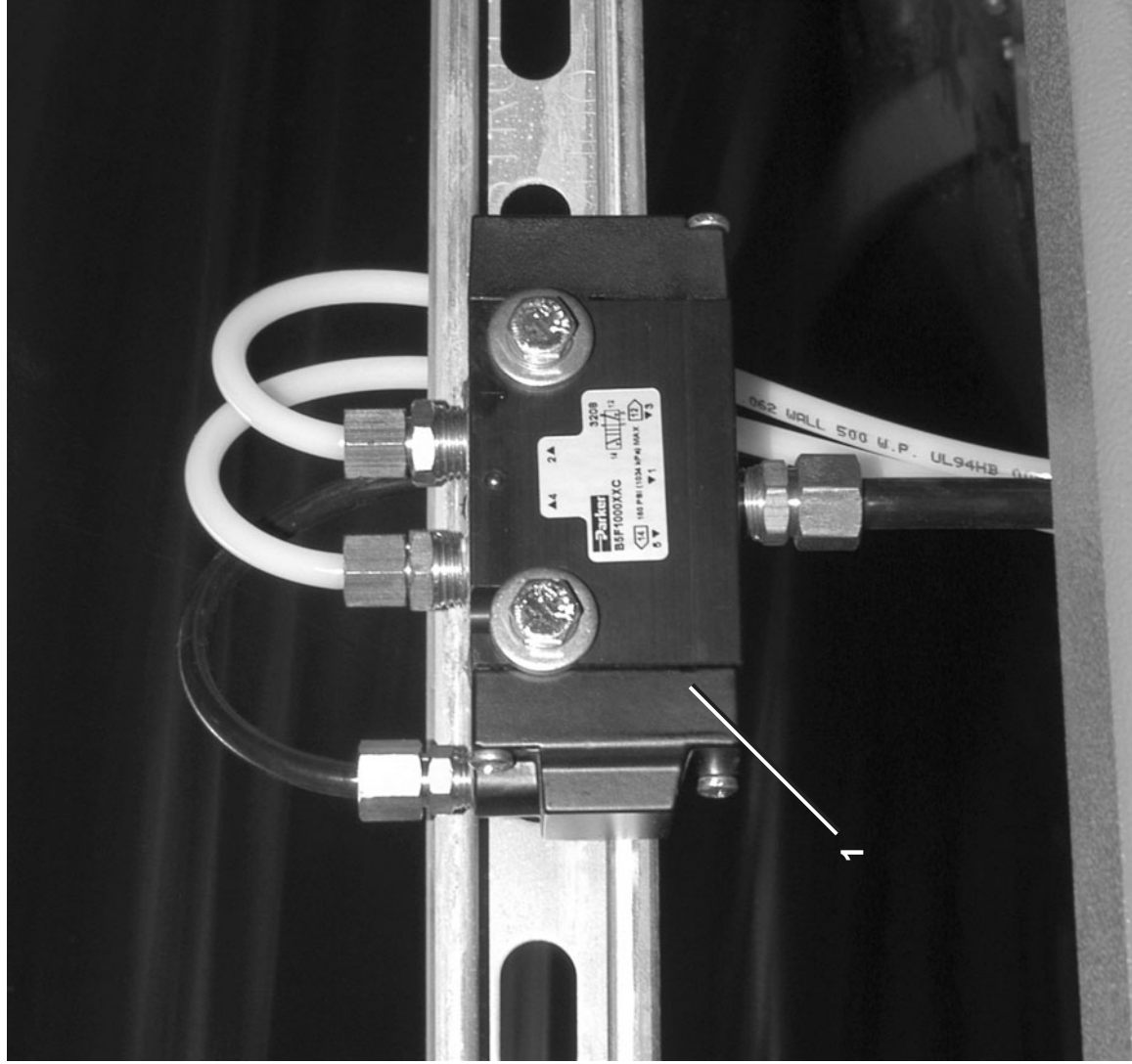

5 Port, 4 Way, 2 Position, Spring Return Valve

Installation

3

ATTENTION INSTALLERS!



PRESS MUST BE HIGH ENOUGH

If you set the press at a low area of the floor, you may not have sufficient clearance for the tunnel. It will be necessary to reinstall the press higher.

- Establish the System Zero Line or Z.
- Refer to the dimensional drawings of the various machines for required heights.

FLOOR IS UNEVEN

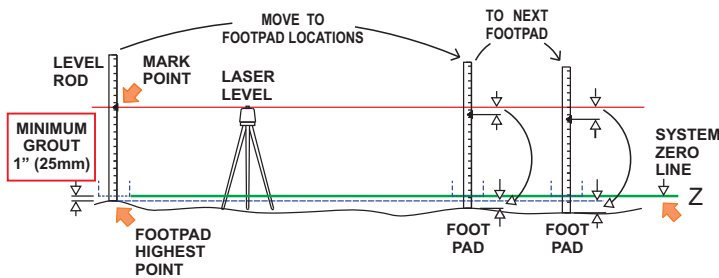

- Establish System Zero Line or Z.
- Find highest point in factory floor where footpads will be located.
- System Zero Line or Z is 1" above highest point.

INSTALL PRESS FIRST

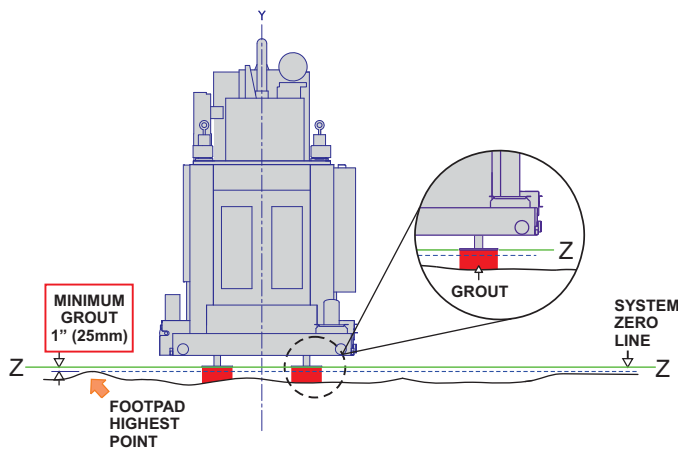

- Shim & level to System Zero Line or Z.
- Grout & anchor all footpads.

INSTALL TUNNEL

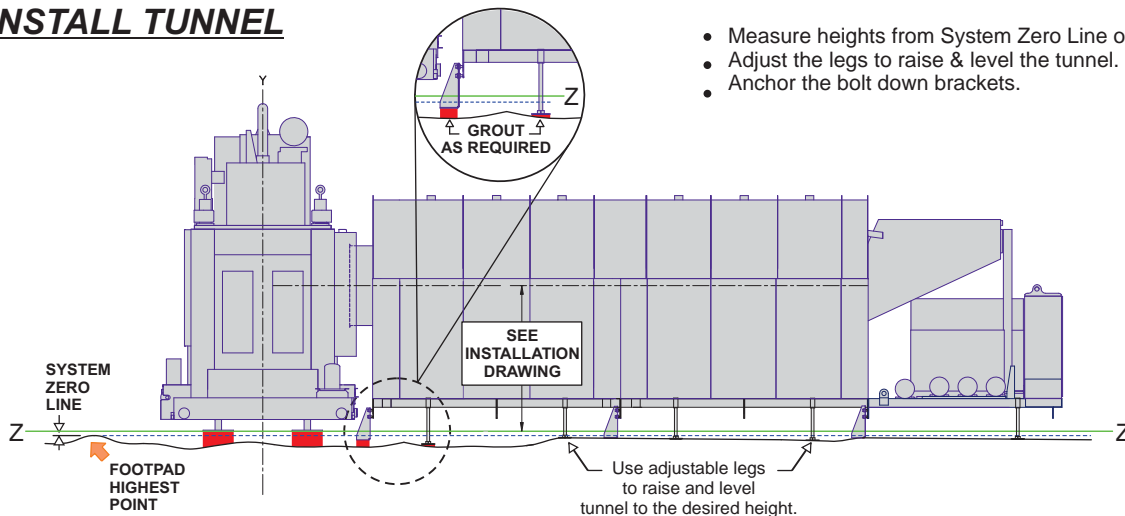

- Measure heights from System Zero Line or Z.
- Adjust the legs to raise & level the tunnel.
- Anchor the bolt down brackets.

Shipping and Lifting Brackets

92048G4 Tunnel

BMP110068/2011514A
(1 / 2)



Pellerin Milnor Corporation
P. O. Box 400, Kenner, LA 70063-0400

Litho in U.S.A.

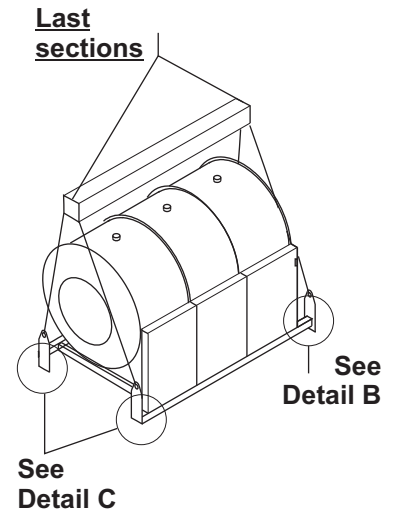
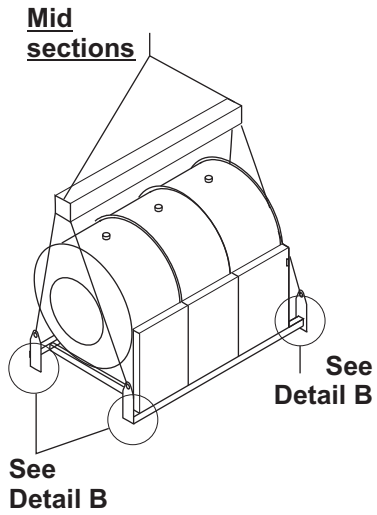
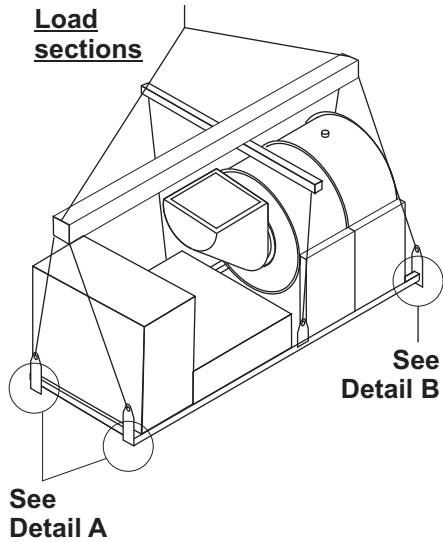

The 9248 G4 tunnel is broken down into combinations of 2-3 modules for shipping. The load chute is always shipped with 1 or 2 modules attached. Use six point lifting for this configuration. The remaining modules are shipped in sections of 2-3 modules. Use four point lifting for these sections.

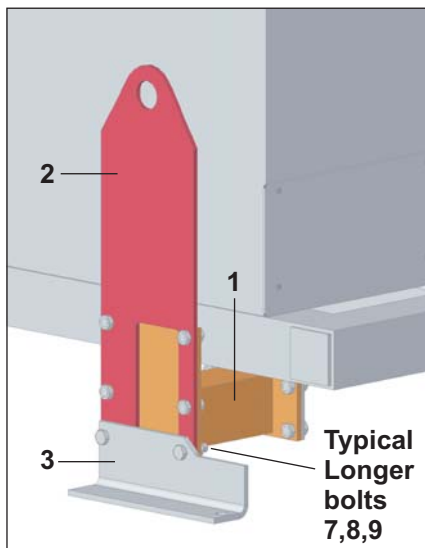

Detail A:

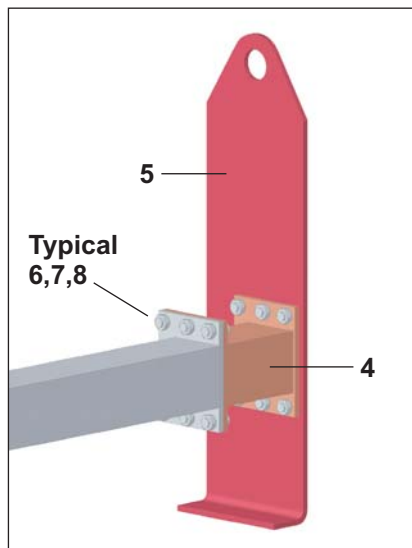

Detail B:

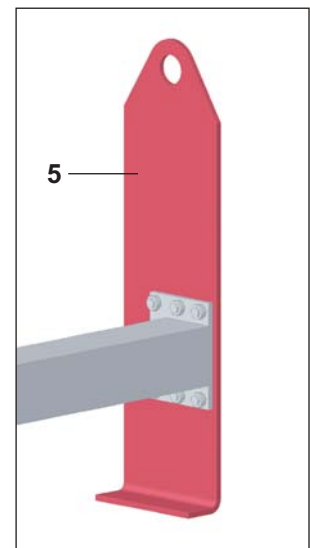

Detail C:



Pellerin Milnor Corporation
P. O. Box 400, Kenner, LA 70063-0400

Litho in U.S.A.

Parts List—Shipping & Lifting Brackets

Find the correct assembly first, then find the needed components. The item letters (A, B, C, etc.) assigned to assemblies are referred to in the "Used In" column to identify which components belong to an assembly. The item numbers (1, 2, 3, etc.) assigned to components relate the parts list to the illustration.

Used In	Item	Part Number	Description	Comments
-----COMPONENTS-----				
all	1	W6 70093	EXTENSION 9-3/4"=SHIPPING BRKT	
all	2	06 70016B	G3 SHIPPING/LIFTING PLATE	
all	3	06 70016	BOLT DOWN BKT SHIPPING-RIGHT	
all	3	06 70016A	BOLT DOWN BKT SHIPPING-LEFT	
all	4	W6 30038J	9248 LIFTING BRKT EXTENSION	
all	5	06 30087	REUSE BASE LIFTING BRKT	
all	6	15K222B	HEXCAPSCR 5/8-11 UNCX1+3/4 GR5	
all	7	15U315	LOKWASHER MEDIUM 5/8 ZINCPL	
all	8	15G238	HXNUT 5/8-11UNC2B SAE ZINC GR2	
all	9	15K222A	HEXCAPSCR 5/8-11X3/4 GR8	

Tunnel Feet

92048G4 Tunnel

BMP110067/2011476A
(1 / 1)



Pellerin Milnor Corporation
P. O. Box 400, Kenner, LA 70063-0400

Litho in U.S.A.

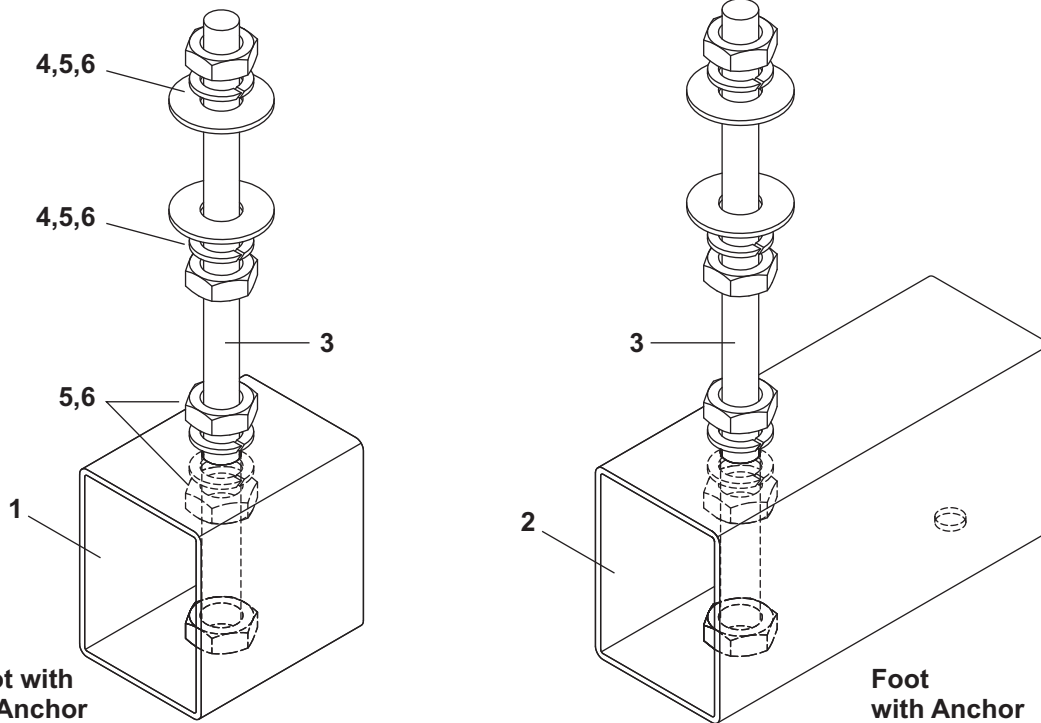

Parts List—Tunnel Feet

Find the correct assembly first, then find the needed components. The item letters (A, B, C, etc.) assigned to assemblies are referred to in the "Used In" column to identify which components belong to an assembly. The item numbers (1, 2, 3, etc.) assigned to components relate the parts list to the illustration.

Used In	Item	Part Number	Description	Comments
-----ASSEMBLIES-----				
	A	AFT63001	9238 FOOT NO ANCHOR ASSY	
	B	AFT63002	9238 FOOT WITH ANCHOR ASSY	
-----COMPONENTS-----				
all	1	W6 30056	FOOT MOUNT BRKT SHORT WLMT	
all	2	W6 30056A	FOOT MNT BRKT W/ANCHOR WLMT	
all	3	17R125A26K	STUD 1.25-8UNX26.5 ALLTHRD. ZN	
all	4	15U440	FLATWASH(USS STD) 1+1/8" STLHD	
all	5	15G261	HVHXNUT 1+1/4-8UNC2B ZINC GR2H	
all	6	15U425	LOCKWASHER MEDIUM 1+1/4"ZINC P	

Connecting Ancillary Equipment and Services

1. Placement of Ancillary Components

Ancillary components not mounted to the tunnel must be installed close to the tunnel washer. The locations for your system should be shown on the system layout drawings. Recommended locations are also shown on the standard dimensional drawings for the tunnel and related equipment.

Set the Mentor console on a flat surface. Bolt the console to the floor if desired. The following ancillary components apply to conventional tunnels only, not PulseFlow tunnels: Install the reuse, flow-splitter, and flow lifter tanks on grout so that they are level, cannot move, and sealed against dirt and grime where the tank meets the floor. The top edge of the dam for the wire filter must be level so that water is evenly distributed over the surface of the wire filter. Additionally the flow-splitter and flow-lifter tanks must be low enough that the tank inlet is at or below the level of the weir box outlet. Set all pumps flat on the slab so that they are as low as possible.

2. Plumbing Connections

The sizes and locations of utility connections vary with machine configuration. Those for your system should be shown on the system layout drawings. The following general instructions apply to all systems.

- 2.1. **Fresh Water**—Incoming fresh water connects to the fresh water header which connects to each fresh water inlet. The following applies to 76032_ (G1) tunnels only: Although the ball valve actuators are fitted with needle valves to adjust the rate at which the valves close, there is some possibility that water hammer will be experienced if the incoming water pressure is above 50 PSI (345 Kpa) - especially if the water piping is small and/or not fastened securely. For severe conditions it may be necessary to install pressure regulators and/or shock absorbers on the water lines.
- 2.2. **Reuse Water**—On-site connections are necessary for some reuse water (example: water returned to the reuse or pulse flow tank from the extraction system). This piping is shown on the layout drawings for your system.
- 2.3. **Steam**—Connect main steam (at the steam strainer) to the tunnel washer steam header. Install a manual steam shutoff valve so the steam valves can be repaired. Discharge condensate into the tunnel drain trough. Do not return condensate to the boiler.
- 2.4. **Compressed Air**—Estimated compressed air consumption is approximately 5 SCFM per minute at a minimum of 85 PSI.
- 2.5. **Drains for Discharged Water**—Consult local codes for equipment that can be necessary (example: traps) when you connect to a sanitary sewer. In addition to the module outlets to the sewer, the machine also has drain-off connections for water that drips between modules or units.
- 2.6. **Vents for Discharged Vapors**—Vapors generated in the oxidation zone and the finish zone of the tunnel can mix together, produce noxious gasses, and corrode equipment. Without adequate ventilation, these vapors will exit the tunnel discharge ring or concentrate in the discharge end of the tunnel and adjacent press enclosure. The severity varies with chemical composition and usage, but corrosion can be rapid and severe.

Each tunnel module is provided with a vent at the top of the shell. These vents are capped at the factory for shipping. **Uncap all vents at installation.** The best practice is to provide two separate, powered ventilation units that meet the following conditions:

- The two units are isolated from each other to avoid harmful chemical reactions.
- Ventilation fans have sufficient power to draw vapors away from the equipment. Milnor recommends 600 to 750 SCFM for the oxidation zone (300 to 375 per connection point, if two modules) and 600 to 750 SCFM for the finish zone plus the press enclosure (200 to 250 SCFM per connection point, if two modules plus the press). The SCFM values are based on an ambient air temperature of 68°F (20°C) and a minimal relative humidity.
- Fan motors are equipped with an alarm (example: indicator light) to alert personnel if a motor fails.

Figure 1 shows the recommended configuration for a tunnel with more than seven modules. Smaller tunnels are similar, but consult the Milnor factory.

Figure 1: Recommended Vent System for the CBW® Tunnel Washer and an Adjacent Press

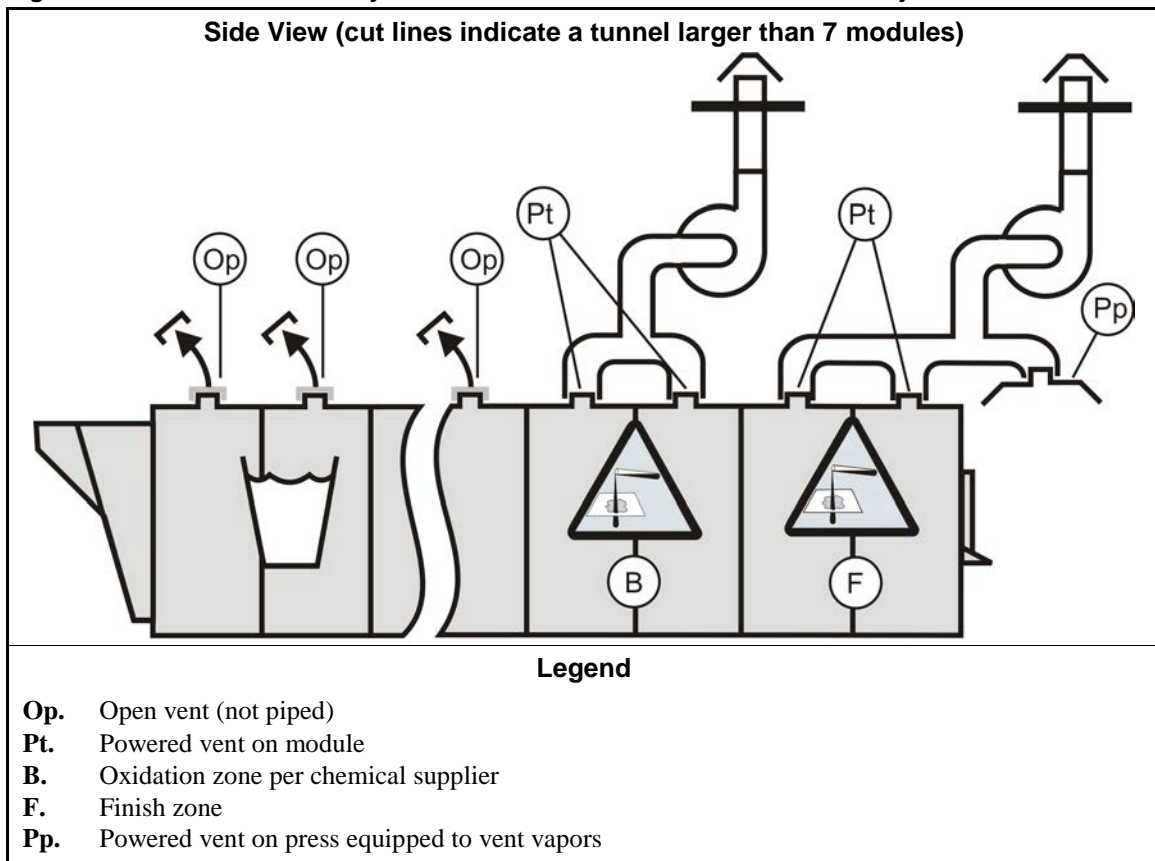

It is not recommended to connect modules ahead of the oxidation zone to a powered vent system. However, if conditions warrant this, Milnor recommends the configuration shown in Figure 2. If this configuration is needed, add 200 to 250 SCFM of powered ventilation per additional module vented.

Figure 2: Alternate Vent System for the CBW® Tunnel Washer and an Adjacent Press

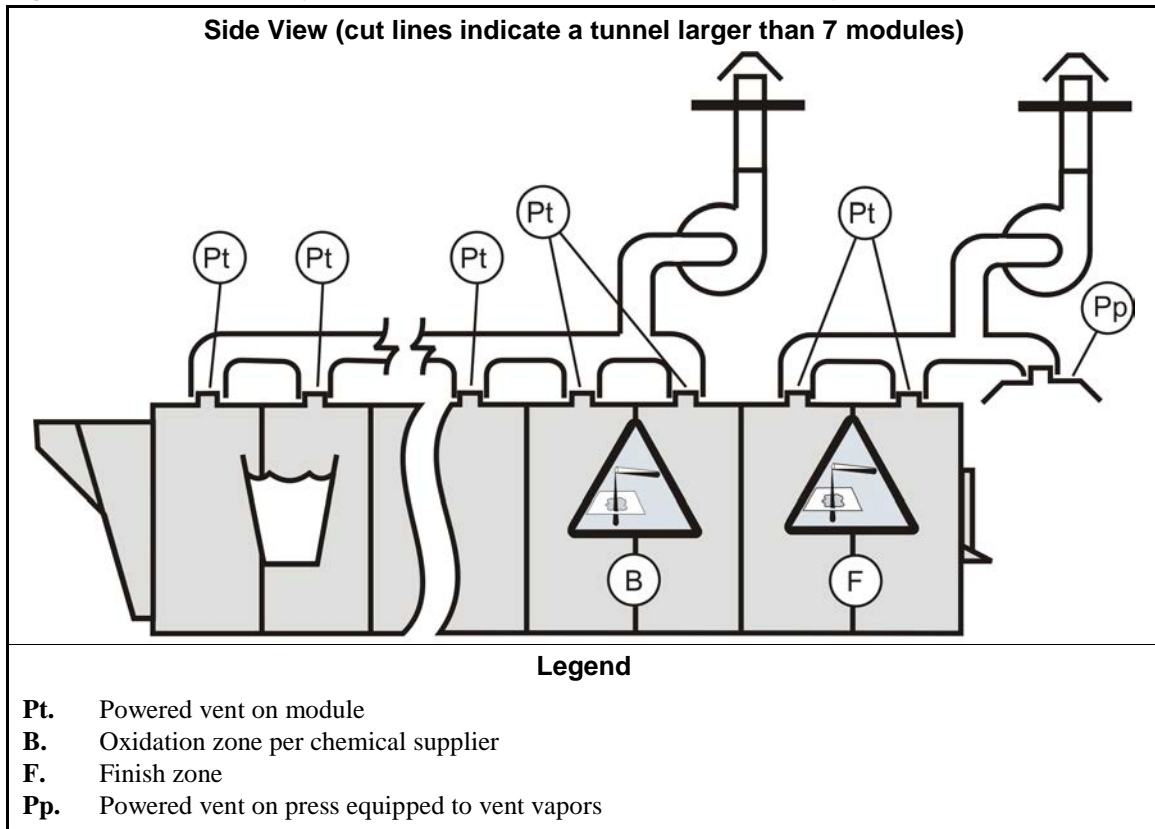

- 2.7. Connections For Chemical Injection**—Make sure that the piping or tubing used to deliver the chemicals to chemical injection points has correct characteristics (working pressure, burst pressure, temperature resistance, chemical resistance, etc.) for the purpose intended. Remember that momentary pressures two or three times the normal chemical pressure can occur as a chemical valve closes.

Be sure the chemical lines are routed such that they are not subject to damage from external heat sources, or abrasion, or any other source of mechanical damage. Inspect all chemical delivery piping daily for leaks, loose connections, frayed or abraded areas, soft or weak places.



CAUTION 1: Machine Damage Hazards—Pumped chemical systems, if not properly installed, can cause corrosion damage.

- See the installation manual for precautions and additional information before making any chemical connections.

3. Power Connections

A junction box is available at either end of the tunnel washer to supply power to the entire tunnel washer, each of the pumps (up to 5 pumps), the motor for the Conlo (or Conwa) and the power for the Mentor.

A single terminal in the inverter enclosure supplies power to the entire tunnel washer, each of the pumps (up to 5 pumps), the motor for the Conlo (or Conwa) and the power for the Mentor.

The Mentor power cable connects to terminals within the standard output box on the first module. Connect one side of the ground wire (in the Mentor power cable) to the ground terminal inside

the standard output box. Connect the other side of the ground wire to the ground terminal inside the mentor enclosure.

4. **Ground (earth) Connections**

A very reliable, secure, and substantial ground (earth) connection is necessary for the proper functioning of any solid state controller. If practical, the ground connection should be via means of a metal rod driven securely at least 3 feet into the earth, and connected to the MENTOR by a copper wire no less than No. 10 AWG (.05 square Millimeter cross section area). The run of copper should not be longer than 10 feet (3 meters).

When it is impossible to provide such a ground connection, the next best is a firm connection to a metal water pipe which is known to be continuous and known to go into the earth a substantial distance.

— End of BIPCUI02 —

3

Dimensional Drawings

3.1

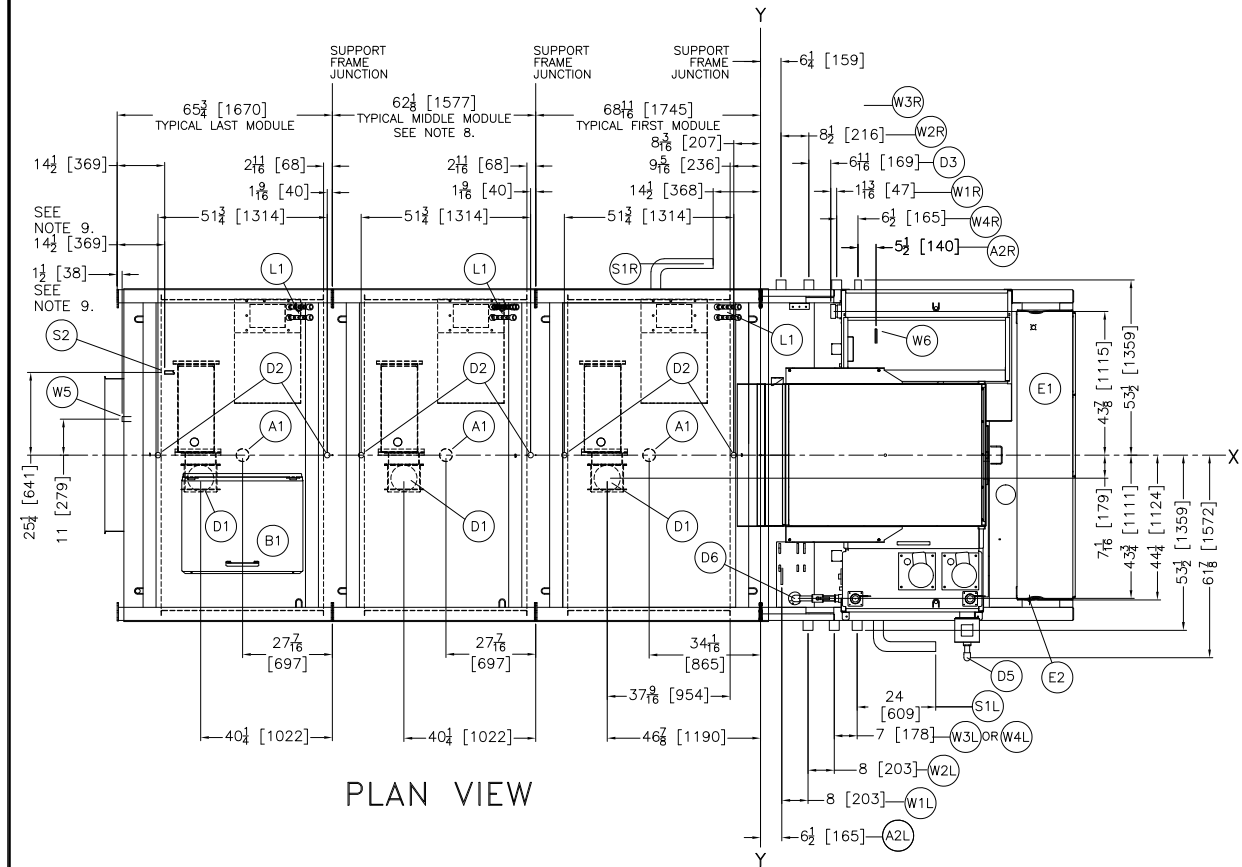

PLAN VIEW

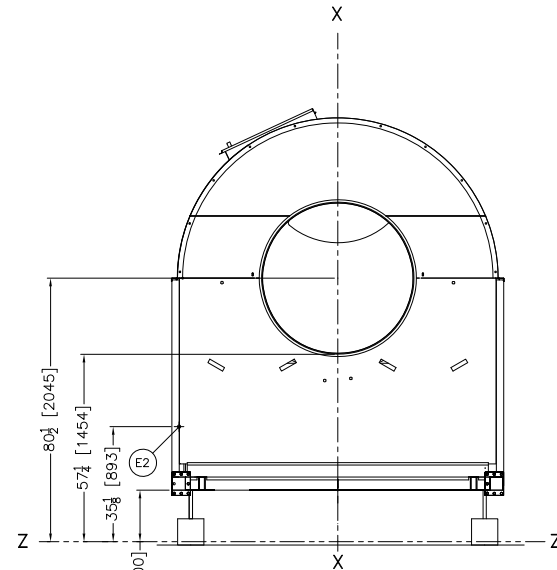

REAR VIEW

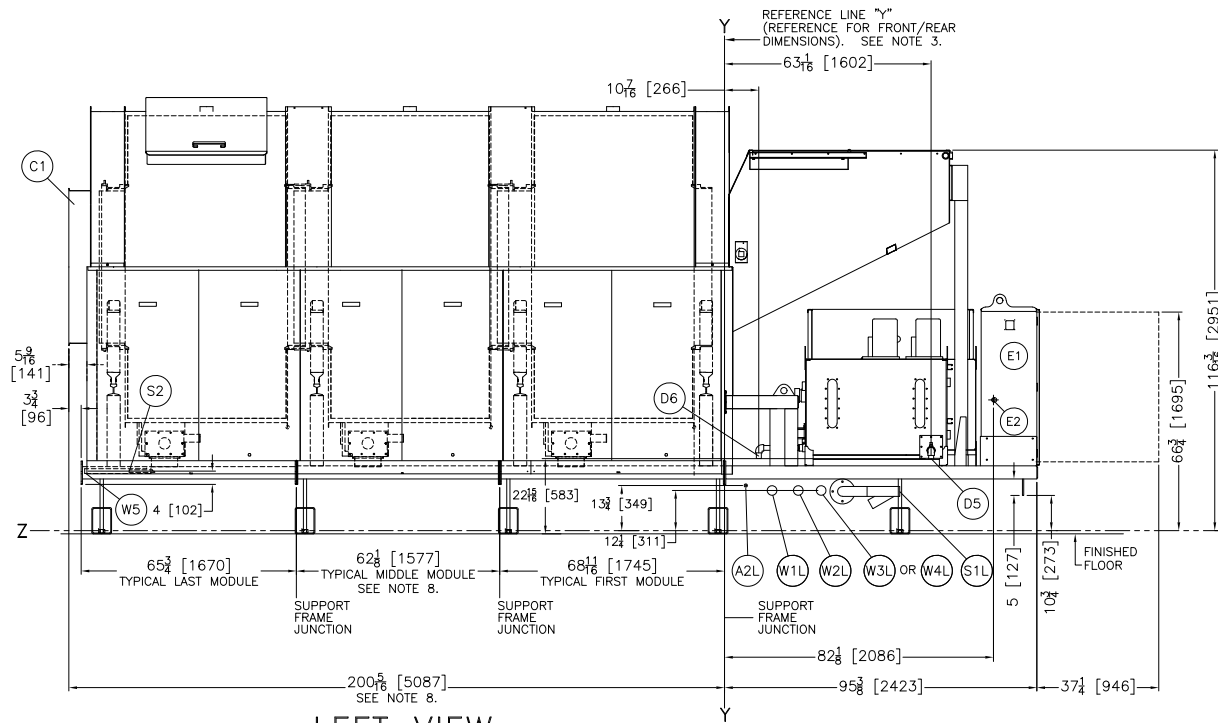

LEFT VIEW

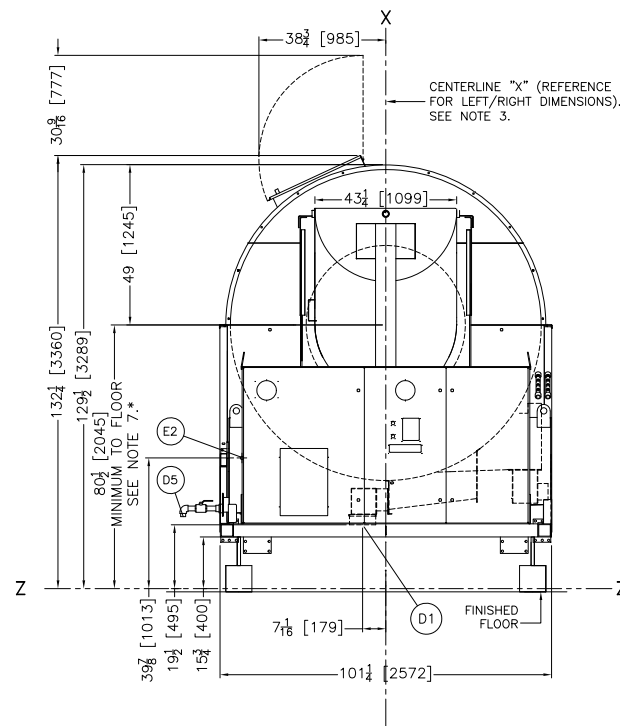

FRONT VIEW

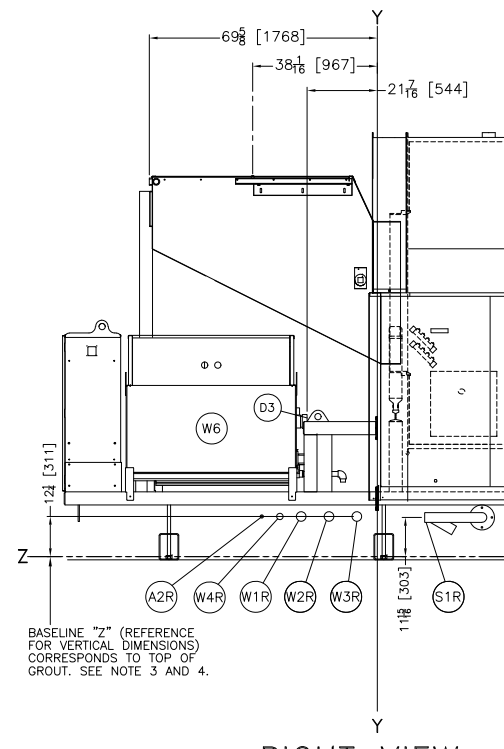

RIGHT VIEW

ITEM	LEGEND
W6	PULSE FLOW TANK
W5	PRESS WATER TO PULSE FLOW TANK, 1-1/2" TOE
W4R	RIGHT WATER HEADER #4 (REUSE) 2" NPT, STANDARD
W3R	RIGHT WATER HEADER #3, 3" NPT, OPTIONAL
W2R	RIGHT WATER HEADER #2, 3" NPT, OPTIONAL
W1R	RIGHT WATER HEADER #1, 3" NPT
W4L	LEFT WATER HEADER #4 (REUSE) 2" NPT, STANDARD
W3L	LEFT WATER HEADER #3, 3" NPT, OPTIONAL
W2L	LEFT WATER HEADER #2, 3" NPT, OPTIONAL
W1L	LEFT WATER HEADER #1, 3" NPT
T1	DUAL PULSE FLOW TANK
S2	STEAM TRAP, STEAM CONDENSATE OUTLET, 1/2" NPT
S1R	RIGHT STEAM INLET (STANDARD) 3" NPT CONNECTION
S1L	LEFT STEAM INLET (OPTIONAL) 3" NPT CONNECTION
L1	LIQUID SUPPLY INLETS, SEE NOTE 14.
E5	INTERPRET RELAY BOX
E4	FLUSH PUMP INTERFACE BOX
E3	CONNECTION FROM MENTOR CONTROLLER
E2	MAIN ELECTRICAL CONNECTION
E1	ELECTRICAL CONTROL BOX
D6	PF TANK FRESH WATER MANUAL DRAIN, 1-1/2" TOE FOR 2" HOSE
D5	PF TANK REUSE WATER MANUAL DRAIN, 1-1/2" TOE FOR 2" HOSE
D3	PF TANK OVERFLOW TO SEWER, 3" NPT CONNECTION, PVC PIPING SUPPLIED BY PMC.
D2	DRIP DRAINS, 2 PER MODULE, 1-3/4" ID TUBING TO SEWER SUPPLIED
D1	8" DIAMETER DRAIN VALVE, ON SPECIFIED MODULES
C1	DISCHARGE RING FOR M7V4840 & MP1A03CL LOADING
B1	HATCHES ON MODULES 3,5
A2R	MAIN AIR (RIGHT STANDARD), 1/2" NPT.
A2L	MAIN AIR (LEFT OPTIONAL), 1/2" NPT.
A1	TYPICAL EXHAUST VENT, 4" [100] DIAMETER.

- NOTES**
- LIQUID SUPPLY INLETS COME WITH THREE SETS OF SIX FITTINGS, ONE SET OF 3/8" FITTINGS, ONE SET OF 1/2" FITTINGS, AND ONE SET OF PLUGS WHICH ARE SHIPPED ON MACHINE.
 - DIRECT STEAM CONDENSATE TO THE DRAIN TROUGH. DO NOT RETURN CONDENSATE TO THE BOILER BECAUSE OF POSSIBLE CONTAMINATION FROM CHEMICALS IN THE WASH WATER.
 - BACK FLOW PREVENTERS MUST BE INSTALLED IF LOCAL PLUMBING CODES REQUIRE. RECOMMENDED MODELS ARE WATTS SERIES 009. THEY CAN BE PURCHASED LOCALLY OR THROUGH MILNOR. CONTACT MILNOR FACTORY.
 - LEAK OFF FROM DRIP DRAINS MUST BE ROUTED TO DRAIN SUMP. THESE CONNECTIONS ARE SUPPLIED WITH TUBING, MAKING THIS A FLEXIBLE CONNECTION POINT.
 - FOR SIZE AND LOCATION OF ADJUSTABLE FEET AND BOLT DOWN BRACKETS, SEE BDPF92G4FBDDE.
 - AIR, WATER AND STEAM INLETS ARE STANDARD ON THE (RIGHT) AND OPTIONAL ON THE (LEFT). THE INLETS SHOULD BE SPECIFIED FOR THE SIDE OPPOSITE THE LOAD CONVEYOR.
 - LENGTH DIMENSIONS ON THIS DRAWING ARE SHOWN FOR A 3 MODULE TUNNEL. ADDITIONAL MIDDLE MODULES ARE ADDED TO CREATE THE DESIRED NUMBER OF MODULES. SEE BDPF92G4CFDDE, FOR OVERALL LENGTHS OF TUNNEL SIZES.
 - HEIGHT DIMENSIONS ON THIS DRAWING REPRESENT THE 9248 TUNNEL SET TO AN 80 1/2 [2045] CENTERLINE TO PROPERLY INTERFACE WITH ADJACENT MACHINES.
 - AS OF THIS WRITING, THE MINIMUM CLEARANCE REQUIRED BY U.S. NATIONAL ELECTRIC CODES, FROM ELECTRIC BOX TO ANY OBJECT IS:
 36 [914] IF OBJECT IS AN UNGROUNDED (INSULATED) WALL.
 42 [1067] IF OBJECT IS A GROUNDED WALL (i.e. BARE CONCRETE, BRICK, ETC.)
 48 [1219] IF OBJECT IS ANY LIVE PART.
 CHECK LOCAL ELECTRIC CODES FOR FURTHER RESTRICTIONS.
 - CUSTOMER TO SUPPLY CIRCUIT BREAKER OR FUSED BRANCH CIRCUIT DISCONNECT (SAFETY) SWITCHES WITH LAG TYPE FUSES WORKING SOURCE TO MACHINE. A SEPARATE CIRCUIT WIRE MUST BE CONNECTED FROM DISCONNECT TO EQUIPMENT.
 - BASILINE "Z" IS THE REFERENCE FOR ALL VERTICAL DIMENSIONS. ON MACHINES WITH FIXED BASE PADS, BASILINE "Z" CORRESPONDS TO THE BOTTOM OF THE BASE PAD. ON MACHINES WITH ADJUSTABLE FEET, BASILINE "Z" CORRESPONDS TO THE BOTTOM OF THE FEET WHEN ADJUSTED SO THAT THE MACHINE IS AT ITS MINIMUM ACCEPTABLE HEIGHT. ON TRAVELING SHUTTLES, BASILINE "Z" CORRESPONDS TO THE BOTTOM OF THE BOTTOM RAIL. THE DISTANCE BETWEEN BASILINE "Z" AND THE FINISHED FLOOR WILL VARY AS REQUIRED TO ENSURE BASILINE "Z" IS HORIZONTAL AND ANY INTERFACING MACHINES REQUIRING GROUT ARE SET ON A MINIMUM 1" [25] THICK GROUT BED.
 - USE REFERENCE LINES "X", "Y", AND "Z" TO LOCATE ALL SERVICE CONNECTIONS.
 - NUMBERS IN BRACKETS [] DENOTE DIMENSIONS IN MILLIMETERS.
 - ALL DIMENSIONS SHOWN ARE APPROXIMATE, SUBJECT TO NORMAL MANUFACTURING TOLERANCES AND OCCASIONAL CHANGES WITHOUT NOTICE THROUGH REDESIGN AND/OR RELOCATION OF COMPONENTS, ETC. DO NOT USE FOR CONSTRUCTION UNLESS CERTIFIED, AND IN NO EVENT PRE-PIPE CLOSER THAN FIVE FEET FROM MACHINE. FACTORY MUST BE CONSULTED FOR DIMENSIONS IF MACHINE IS TO BE MOVED THROUGH NARROW OR LOW CORRIDORS OR OPENINGS.

ATTENTION
 MOST REGULATORY AUTHORITIES (INCLUDING OSHA IN THE USA) HOLD THE OWNER/USER ULTIMATELY RESPONSIBLE TO MAINTAIN A SAFE WORKING ENVIRONMENT. ACCORDINGLY, THE OWNER/USER MUST RECOGNIZE ALL FORESEEABLE SAFETY HAZARDS, FURNISH SAFETY INSTRUCTIONS AND GUIDANCE TO ALL PERSONNEL WHO MAY COME IN CONTACT WITH THE INSTALLATION, AND PROVIDE ALL NECESSARY ADDITIONAL SAFETY GUARDS, FENCES, RESTRAINTS, DEVICES, ETC., NOT FURNISHED BY THE EQUIPMENT MANUFACTURER OR VENDOR.

ATTENTION
 THE FLOOR AND/OR OTHER SUPPORT COMPONENTS MUST HAVE SUFFICIENT STRENGTH (AND RIGIDITY WITH DUE CONSIDERATION FOR NATURAL OR RESONANT FREQUENCY THEREOF) TO WITHSTAND THE FULLY LOADED WEIGHT OF THE MACHINE INCLUDING THE GOODS, THE WATER, AND ANY REPEATED SINUSOIDAL (ROTATING) FORCES GENERATED DURING ITS OPERATION. WRITE THE FACTORY FOR ADDITIONAL MACHINE DATA FOR USE BY A COMPETENT SOIL AND/OR STRUCTURAL ENGINEER.

9248G4 PF TUNNEL

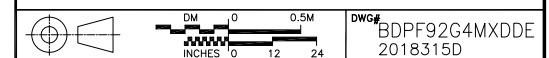

MILNOR PELLERIN MILNOR CORPORATION
 P.O. Box 400 Kenner, LA 70063, USA, Phone 504/467-9591, FAX 504/468-3094, Email: milnorinfo@milnor.com

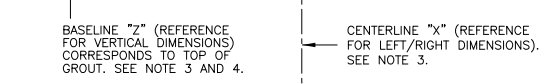
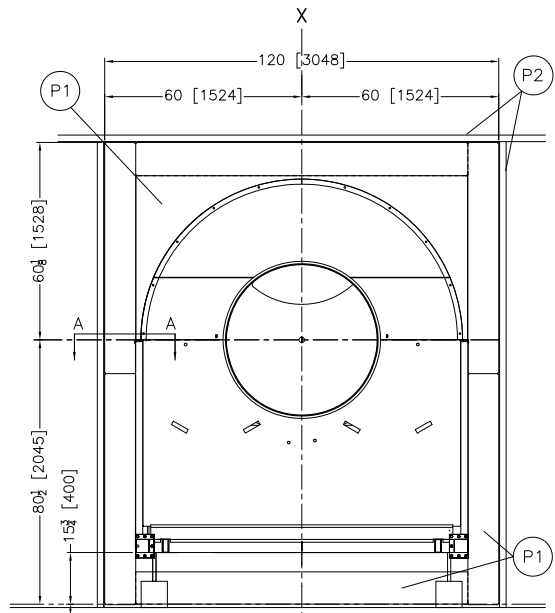
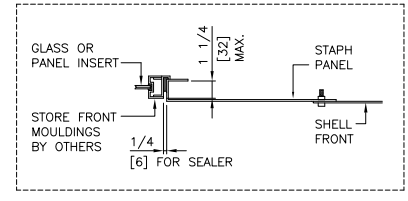
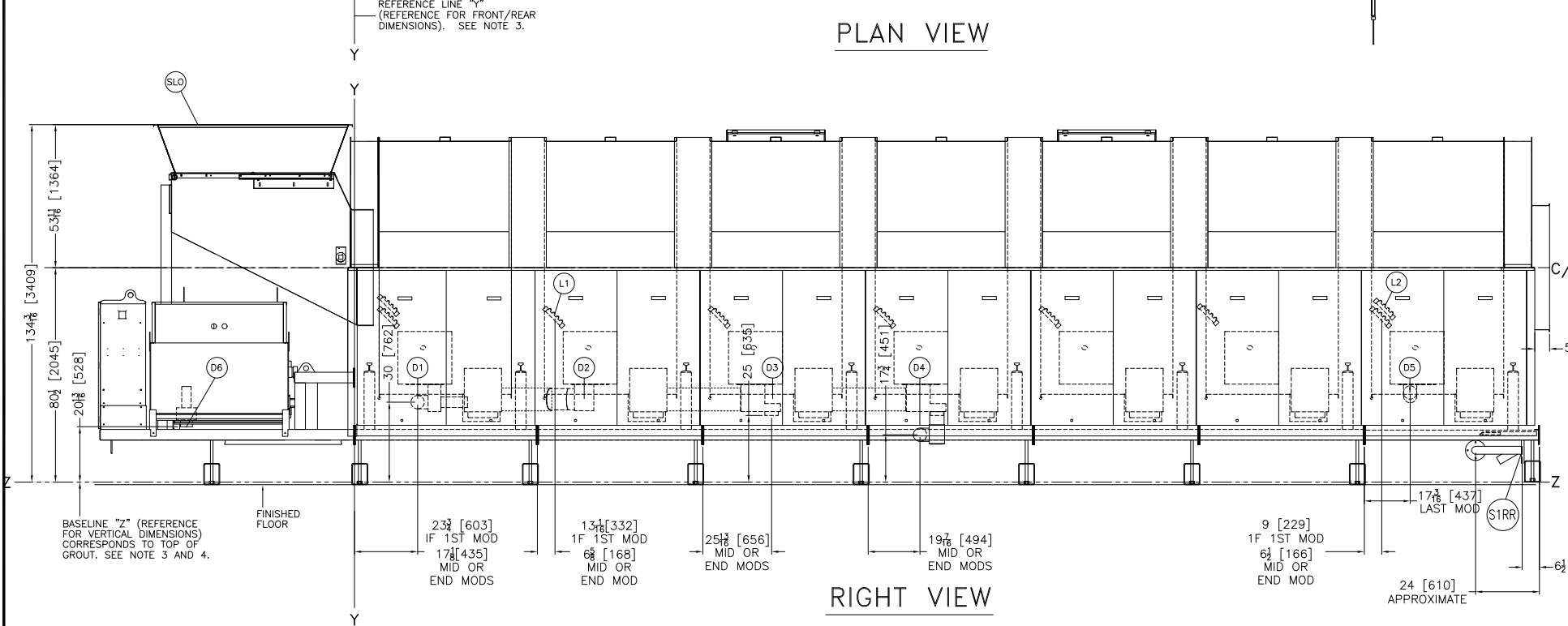
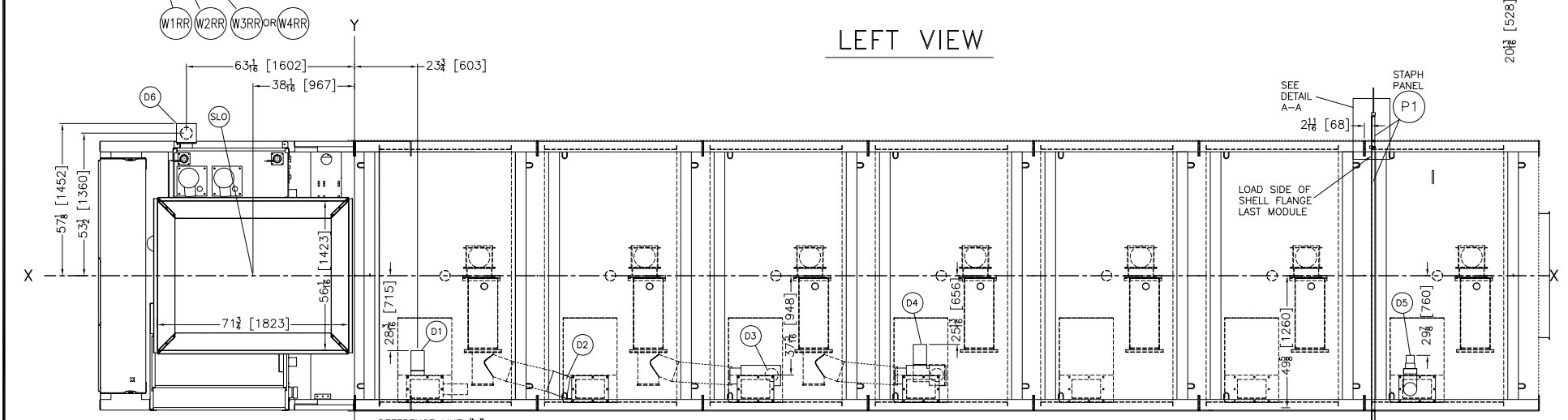
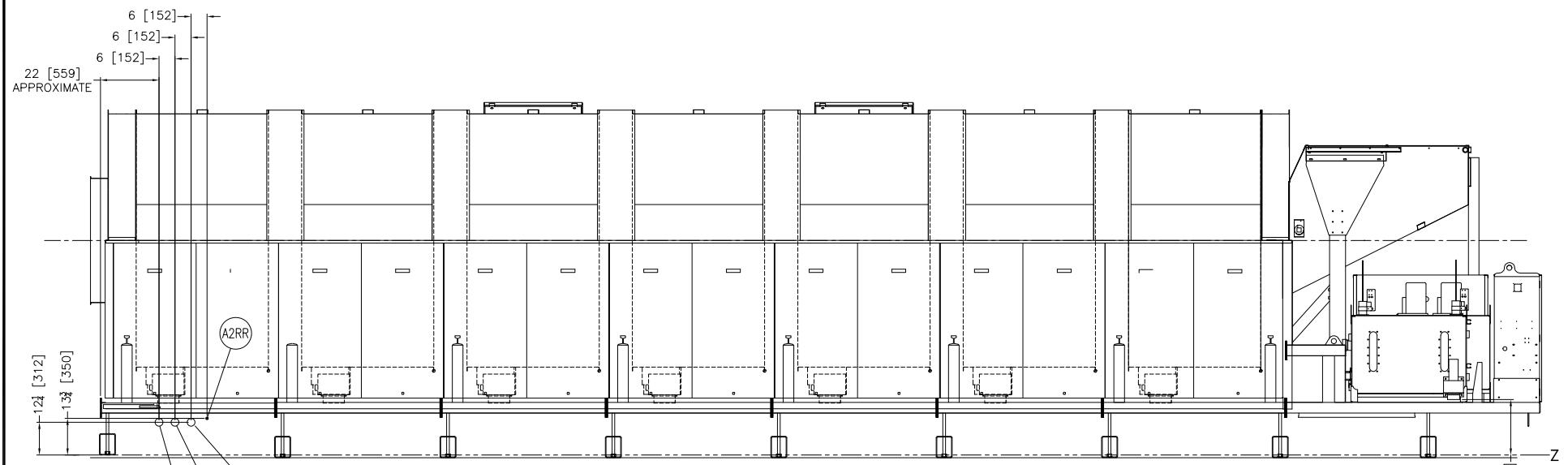

S1RR	REAR STEAM INLET, 3" NPT, RIGHT ONLY
W4RR	REAR WATER HEADER #4 (REUSE) 2" NPT, LEFT ONLY
W3RR	REAR WATER HEADER #3, 3" NPT, OPTIONAL, LEFT ONLY
W2RR	REAR WATER HEADER #2, 3" NPT, OPTIONAL, LEFT ONLY
W1RR	REAR WATER HEADER #1, 3" NPT, OPTIONAL, LEFT ONLY
SLO	OPTIONAL SLING LOADING CHUTE
P2	STORE FRONT MOULDINGS BY OTHERS, SEE DETAIL.
P1	OPTIONAL STAPH GUARD PANEL
L2	(2) 6 PORT PERISTALTIC CONNECTIONS, ON SPECIFIED MODULES
L1	6 PORT PERISTALTIC CONNECTION, ON SPECIFIED MODULES
D6	OPTIONAL PF TANK AUTO DRAIN, 4-1/2" HOSE CONNECTION
D5	FLOW TO PRESS OR EXTRACTOR, TYPICAL OF THE LAST TUNNEL MODULE, 3" TOE CONNECTION, FOR 3-1/2" HOSE SUPPLIED BY PMC.
D4	FLOWNOT, DRAIN TO SEWER, WITH FLOW STOP, 5" HOSE CONNECTION, 4"x36" PIPE & ELBOW TO SEWER SUPPLIED
D3	FLOWNOT, DRAIN TO SEWER, 5" HOSE CONNECTION, 4"x36" PIPE & ELBOW TO SEWER SUPPLIED
D2	FLOW TO LOAD, AT UNIT CONNECT, NO CONNECTION
D1	FLOW TO SEWER, (FLOW STOP SHOWN) 5" HOSE CONNECTION, 4"x36" PIPE TO SEWER SUPPLIED

LEGEND

NOTES

- LIQUID SUPPLY INLETS COME WITH THREE SETS OF SIX FITTINGS. ONE SET OF 3/8" FITTINGS, ONE SET OF 1/2" FITTINGS, AND ONE SET OF PLUGS WHICH ARE SHIPPED ON MACHINE.
- AS OF THIS WRITING, THE MINIMUM CLEARANCE REQUIRED BY U.S. NATIONAL ELECTRIC CODES, FROM ELECTRIC BOX TO ANY OBJECT IS:
 36 [914] IF OBJECT IS AN UNGROUNDED (INSULATED) WALL
 42 [1067] IF OBJECT IS A GROUNDED WALL (i.e. BARE CONCRETE, BRICK, ETC.)
 48 [1219] IF OBJECT IS ANY LIVE PART.
 CHECK LOCAL ELECTRIC CODES FOR FURTHER RESTRICTIONS.
- CUSTOMER TO SUPPLY CIRCUIT BREAKER OR FUSED BRANCH CIRCUIT DISCONNECT (SAFETY) SWITCHES WITH LAG TYPE FUSES FROM POWER SOURCE TO MACHINE. A SEPARATE GROUND WIRE MUST BE CONNECTED FROM DISCONNECT TO EQUIPMENT.
- BASELINE "Z" IS THE REFERENCE FOR ALL VERTICAL DIMENSIONS, ON MACHINES WITH FIXED BASE PADS, BASELINE "Z" CORRESPONDS TO THE BOTTOM OF THE BASE PAD. ON MACHINES WITH ADJUSTABLE FEET, BASELINE "Z" CORRESPONDS TO THE BOTTOM OF THE FEET WHEN ADJUSTED SO THAT THE MACHINE IS AT ITS MINIMUM ACCEPTABLE HEIGHT. ON TRAVELING SHUTTLES, BASELINE "Z" CORRESPONDS TO THE BOTTOM OF THE BOTTOM RAIL. THE DISTANCE BETWEEN BASELINE "Z" AND THE FINISHED FLOOR WILL VARY AS REQUIRED TO ENSURE BASELINE "Z" IS HORIZONTAL AND ANY INTERFACING MACHINES REQUIRING GROUT ARE SET ON A MINIMUM 1" [25] THICK GROUT BED.
- USE REFERENCE LINES "X", "Y", AND "Z" TO LOCATE ALL SERVICE CONNECTIONS.
- NUMBERS IN BRACKETS [] DENOTE DIMENSIONS IN MILLIMETERS.
- ALL DIMENSIONS SHOWN ARE APPROXIMATE, SUBJECT TO NORMAL MANUFACTURING TOLERANCES, AND TO OCCASIONAL CHANGES WITHOUT NOTICE THROUGH REDESIGN AND/OR RELOCATION OF COMPONENTS, ETC. DO NOT USE FOR CONSTRUCTION UNLESS CERTIFIED, AND IN NO EVENT PRE-PIPE CLOSER THAN FIVE FEET FROM MACHINE. FACTORY MUST BE CONSULTED FOR DIMENSIONS IF MACHINE IS TO BE MOVED THROUGH NARROW OR LOW CORRIDORS OR OPENINGS.

ATTENTION

MOST REGULATORY AUTHORITIES (INCLUDING OSHA IN THE USA) HOLD THE OWNER/USER ULTIMATELY RESPONSIBLE TO MAINTAIN A SAFE WORKING ENVIRONMENT. ACCORDINGLY, THE OWNER/USER MUST RECOGNIZE ALL FORESEEABLE SAFETY HAZARDS, FURNISH SAFETY INSTRUCTIONS AND GUIDANCE TO ALL PERSONNEL WHO MAY COME IN CONTACT WITH THE INSTALLATION, AND PROVIDE ALL NECESSARY ADDITIONAL SAFETY GUARDS, FENCES, RESTRAINTS, DEVICES, ETC., NOT FURNISHED BY THE EQUIPMENT MANUFACTURER OR VENDOR.

ATTENTION

THE FLOOR AND/OR OTHER SUPPORT COMPONENTS MUST HAVE SUFFICIENT STRENGTH (AND RIGIDITY WITH DUE CONSIDERATION FOR NATURAL OR RESONANT FREQUENCY THEREOF) TO WITHSTAND THE FULLY LOADED WEIGHT OF THE MACHINE INCLUDING THE GOODS, THE WATER, AND ANY REPEATED SINUSOIDAL (ROTATING) FORCES GENERATED DURING ITS OPERATION. WRITE THE FACTORY FOR ADDITIONAL MACHINE DATA FOR USE BY A COMPETENT SOIL AND/OR STRUCTURAL ENGINEER.

9248G4 PF TUNNEL OPTIONS

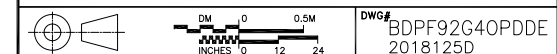

MILNOR PELLERIN MILNOR CORPORATION
 P.O. Box 400 Kenner, LA 70063, USA, Phone 504/467-9591,
 FAX 504/468-3094, Email: milnorinfo@milnor.com

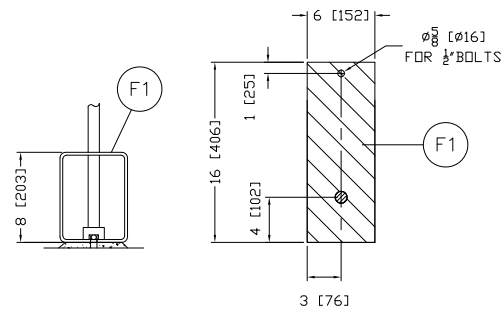

ADJUSTABLE
BOLT DOWN
FOOT

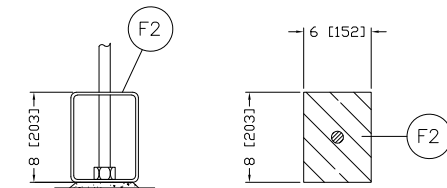

ADJUSTABLE
FOOT

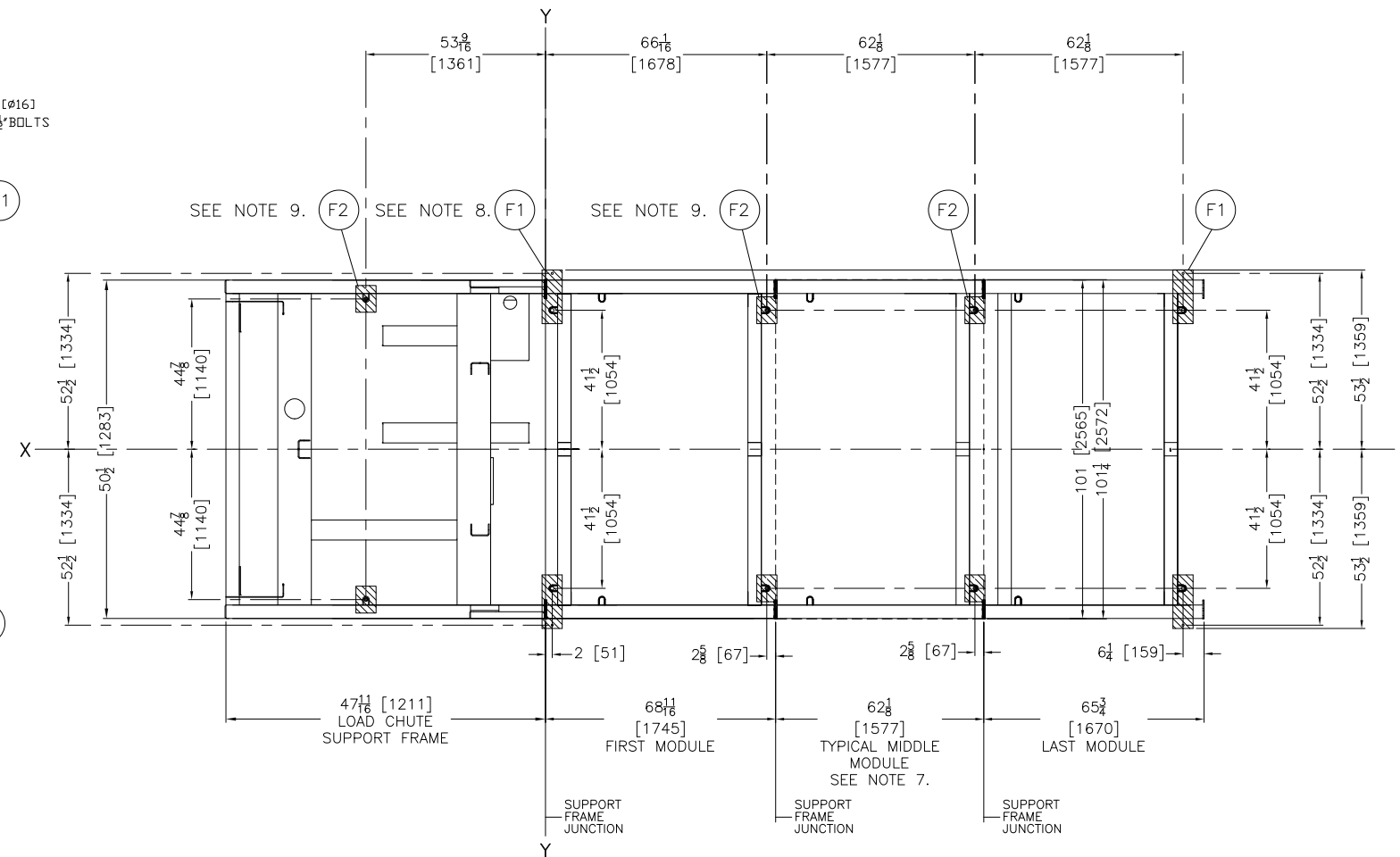

FOUNDATION PLAN VIEW

F2	ADJUSTABLE FOOT, SEE NOTE 9.
F1	ADJUSTABLE BOLT DOWN FOOT, ANCHOR BOLT HOLE 5/8" [16] FOR 1/2 BOLTS, SEE NOTE 8.

ITEM	LEGEND
------	--------

NOTES

- THE ADJUSTABLE FEET ARE USED TO SUPPORT THE MACHINE. ADJUSTABLE FEET ARE USED IN EACH MODULE AS SHOWN IN THE FOUNDATION PLAN VIEW. GROUT AS REQUIRED.
- THE ADJUSTABLE BOLT DOWN FEET ARE USED TO PREVENT THE TUNNEL FROM "WALKING" AND MUST BE INSTALLED IN ADDITION TO THE ADJUSTABLE FEET WHICH SUPPORT THE MACHINE. A PAIR OF BOLT DOWN FEET MUST BE INSTALLED AT THE FRONT OF THE FIRST MODULE AND ON THE END OF THE LAST MODULE. AS SHOWN IN THE FOUNDATION PLAN VIEW. GROUT AS REQUIRED.
- 9248 TUNNELS CAN BE ORDERED IN VARIOUS MODULE LENGTHS. THIS DRAWING SHOWS A BASIC 3 MODULE TUNNEL (FIRST, MIDDLE & LAST). TO LAYOUT THE FOUNDATION PLAN FOR LONGER TUNNELS, DUPLICATE THE MIDDLE MODULE TO ACHIEVE THE TOTAL NUMBER OF MODULES IN THE TUNNEL.
- AS OF THIS WRITING, THE MINIMUM CLEARANCE REQUIRED BY U.S. NATIONAL ELECTRIC CODES, FROM ELECTRIC BOX TO ANY OBJECT IS:
36 [914] IF OBJECT IS AN UNGROUNDED (INSULATED) WALL.
42 [1067] IF OBJECT IS A GROUNDED WALL (i.e. BARE CONCRETE, BRICK, ETC.)
48 [1219] IF OBJECT IS ANY LIVE PART.
CHECK LOCAL ELECTRIC CODES FOR FURTHER RESTRICTIONS.
- CUSTOMER TO SUPPLY CIRCUIT BREAKER OR FUSED BRANCH CIRCUIT DISCONNECT (SAFETY) SWITCHES WITH LAG TYPE FUSES FROM POWER SOURCE TO MACHINE. A SEPARATE GROUND WIRE MUST BE CONNECTED FROM DISCONNECT TO EQUIPMENT.
- BASELINE "Z" IS THE REFERENCE FOR ALL VERTICAL DIMENSIONS. ON MACHINES WITH FIXED BASE PADS, BASELINE "Z" CORRESPONDS TO THE BOTTOM OF THE BASE PAD. ON MACHINES WITH ADJUSTABLE FEET, BASELINE "Z" CORRESPONDS TO THE BOTTOM OF THE FEET WHEN ADJUSTED SO THAT THE MACHINE IS AT ITS MINIMUM ACCEPTABLE HEIGHT. ON TRAVELING SHUTTLES, BASELINE "Z" CORRESPONDS TO THE BOTTOM OF THE BOTTOM RAIL. THE DISTANCE BETWEEN BASELINE "Z" AND THE FINISHED FLOOR WILL VARY AS REQUIRED TO ENSURE BASELINE "Z" IS HORIZONTAL AND ANY INTERFACING MACHINES REQUIRING GROUT ARE SET ON A MINIMUM 1" [25] THICK GROUT BED.
- USE REFERENCE LINES "X", "Y", AND "Z" TO LOCATE ALL SERVICE CONNECTIONS.
- NUMBERS IN BRACKETS [] DENOTE DIMENSIONS IN MILLIMETERS.
- ALL DIMENSIONS SHOWN ARE APPROXIMATE, SUBJECT TO NORMAL MANUFACTURING TOLERANCES, AND TO OCCASIONAL CHANGES WITHOUT NOTICE THROUGH REDESIGN AND/OR RELOCATION OF COMPONENTS, ETC. DO NOT USE FOR CONSTRUCTION UNLESS CERTIFIED, AND IN NO EVENT PRE-PIPE CLOSER THAN FIVE FEET FROM MACHINE. FACTORY MUST BE CONSULTED FOR DIMENSIONS IF MACHINE IS TO BE MOVED THROUGH NARROW OR LOW CORRIDORS OR OPENINGS.

ATTENTION
MOST REGULATORY AUTHORITIES (INCLUDING OSHA IN THE USA) HOLD THE OWNER/USER ULTIMATELY RESPONSIBLE TO MAINTAIN A SAFE WORKING ENVIRONMENT. ACCORDINGLY, THE OWNER/USER MUST RECOGNIZE ALL FORESEEABLE SAFETY HAZARDS, FURNISH SAFETY INSTRUCTIONS AND GUIDANCE TO ALL PERSONNEL WHO MAY COME IN CONTACT WITH THE INSTALLATION, AND PROVIDE ALL NECESSARY ADDITIONAL SAFETY GUARDS, FENCES, RESTRAINTS, DEVICES, ETC., NOT FURNISHED BY THE EQUIPMENT MANUFACTURER OR VENDOR.

ATTENTION
THE FLOOR AND/OR OTHER SUPPORT COMPONENTS MUST HAVE SUFFICIENT STRENGTH (AND RIGIDITY WITH DUE CONSIDERATION FOR NATURAL OR RESONANT FREQUENCY THEREOF) TO WITHSTAND THE FULLY LOADED WEIGHT OF THE MACHINE INCLUDING THE GOODS, THE WATER, AND ANY REPEATED SINUSOIDAL (ROTATING) FORCES GENERATED DURING ITS OPERATION. WRITE THE FACTORY FOR ADDITIONAL MACHINE DATA FOR USE BY A COMPETENT SOIL AND/OR STRUCTURAL ENGINEER.

9248G4 PF FOUNDATION PLAN

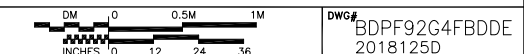

DWG# BDPF92G4FBDDE
2018125D



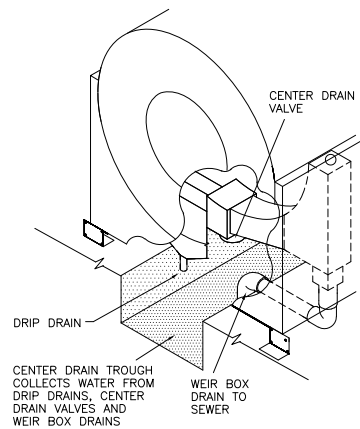

FIGURE 1: CENTER DRAIN TROUGH TUNNELS WITH DRAIN VALVES
SEE NOTES 7 & 8.

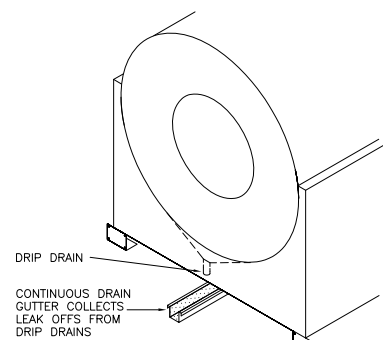

FIGURE 2: CENTER DRAIN TROUGH TUNNELS WITH NO DRAIN VALVES
SEE NOTE 6.

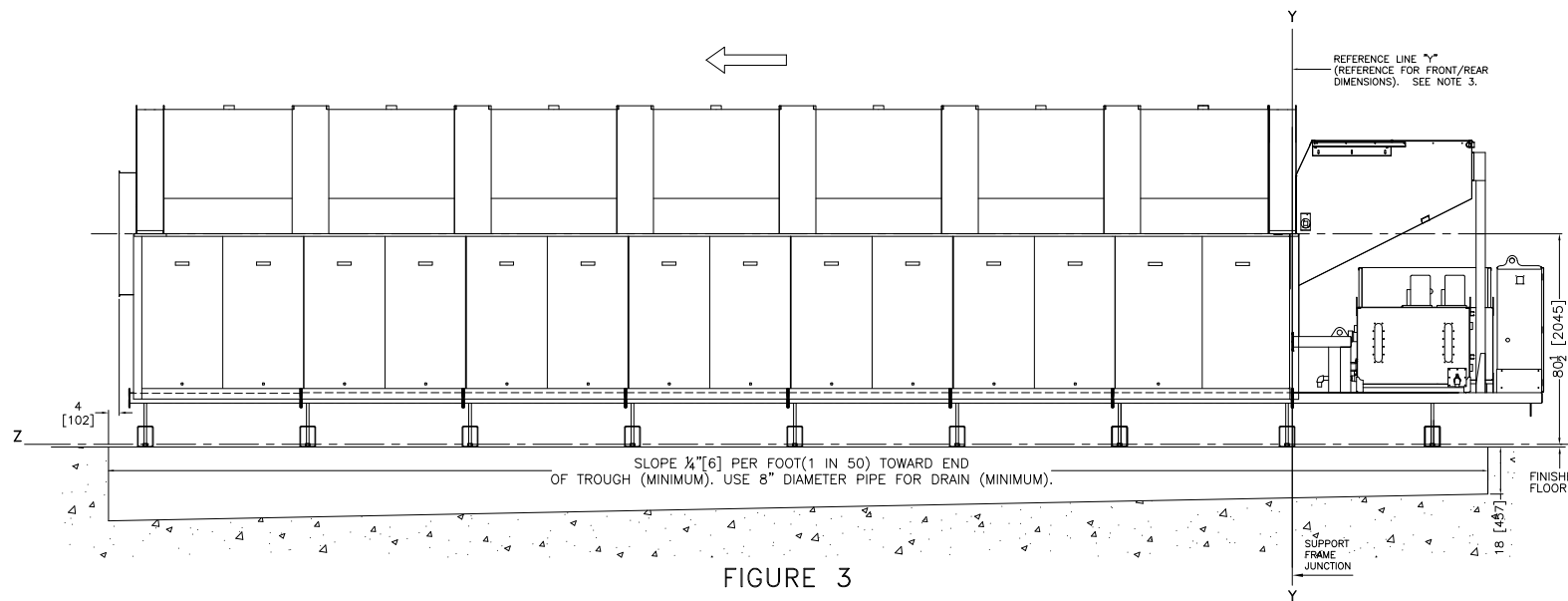
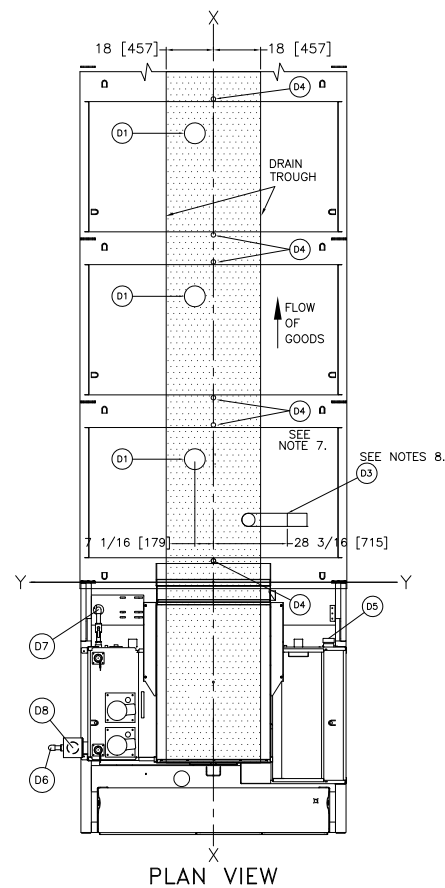
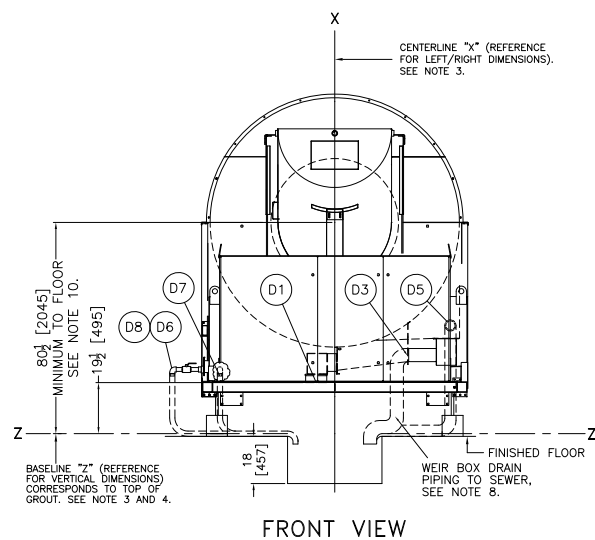

FIGURE 3
LEFT VIEW OF CENTER TROUGH



PLAN VIEW



FRONT VIEW
CENTER DRAIN TROUGH
(SEE NOTES 7 & 8. SEE FIGURE 1.)

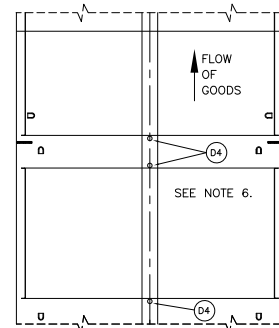

PLAN VIEW

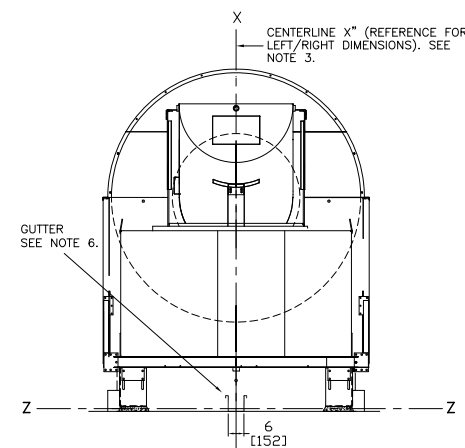

FRONT VIEW

GUTTER FOR DRIIP DRAINS
(SEE NOTE 6. SEE FIGURE 2.)

* SLOPE 1/4 [6] PER FOOT (1 IN 50) TOWARD END OF TROUGH (MINIMUM). USE 8" DIAMETER PIPE FOR DRAIN (MINIMUM).

TUNNEL DRAINS WHICH MUST BE ACCOMMODATED:

- DRIIP DRAINS – (TWO PER MODULE UNIT, 1-3/4 TUBING)
- CENTER DRAIN VALVES – (OPTIONAL 1-2 DRAIN VALVES PER MODULE)
- WEIR BOX DRAINS TO SEWER – (OPTIONAL)
- PULSE FLOW TANK DRAINS (2" AND 5" HOSE CONNECTIONS)

ITEM	LEGEND
D8	OPTIONAL PF TANK REUSE WATER AUTO DRAIN, 4-1/2" ID HOSE CONNECTION FOR 5" HOSE
D7	PF TANK FRESH WATER MANUAL DRAIN, 1-1/2" TOE FOR 2" HOSE
D6	PF TANK REUSE WATER MANUAL DRAIN, 1-1/2" TOE FOR 2" HOSE
D5	PF TANK OVERFLOW TO SEWER, 3" NPT CONNECTION, PVC PIPING SUPPLIED BY PMC.
D4	DRIIP DRAINS, 1-3/4" ID TUBING SUPPLIED
D3	WEIR BOX DRAIN OPTIONS, FLOW TO SEWER, 5" NPT PIPING TO SEWER SUPPLIED BY PMC
D2	REUSE TANK DRAIN, 5" HOSE CONNECTION
D1	CENTER DRAIN VALVES, 8" DIAMETER, ON SPECIFIED MODULES

- NOTES**
- 10 HEIGHT DIMENSIONS ON THIS DRAWING REPRESENT THE 9248 TUNNEL SET TO AN 80 1/2 [2045] CENTERLINE TO PROPERLY INTERFACE WITH ADJACENT MACHINES. FOR THE 9248 TUNNEL'S MINIMUM CENTERLINE, SEE B092G4MXDDE. CONSULT MILNOR FACTORY.
 - 9 WEIR BOX DRAIN PIPING TO SEWER SUPPLIED BY PMC.
 - 8 A CENTER DRAIN TROUGH OR ITS EQUIVALENT IS NECESSARY TO COLLECT THE LEAK OFFS FROM THE DRIIP DRAINS AND THE WATER FROM UNITS WITH A CENTER DRAIN VALVE.
 - 7 WHEN THERE ARE NO CENTER DRAIN VALVES OR WEIR BOX DRAINS, A CONTINUOUS OPEN DRAIN GUTTER FABRICATED OF STAINLESS STEEL, COPPER OR PLASTIC IS REQUIRED TO COLLECT THE LEAK OFFS FROM THE DRIIP DRAINS. THESE DRIIP DRAINS ABSOLUTELY MUST NOT BE PIPED WITH CLOSED PIPING WHICH WILL COLLECT LINT AND BLOCK.
 - 6 NOTE THIS DRAWING SHOWS THE RECOMMENDED DRAIN TROUGH DESIGN FOR THE 9248 (D4) TUNNEL. DRAIN TROUGH CONSTRUCTION IS THE RESPONSIBILITY OF OTHERS. THIS DRAWING CONVEYS NO EXPRESS OR IMPLIED WARRANTY WITH REGARD TO THE CONSTRUCTION AND/OR SUITABILITY OF THESE DESIGNS FOR YOUR SPECIFIC INSTALLATION.
 - 6 AS OF THIS WRITING, THE MINIMUM CLEARANCE REQUIRED BY U.S. NATIONAL ELECTRIC CODES, FROM ELECTRIC BOX TO ANY OBJECT IS:
36 [914] IF OBJECT IS AN UNGROUNDED (INSULATED) WALL
42 [1067] IF OBJECT IS A GROUNDED WALL (i.e. BARE CONCRETE, BRICK, ETC.)
48 [1219] IF OBJECT IS ANY LIVE PART.
CHECK LOCAL ELECTRIC CODES FOR FURTHER RESTRICTIONS.
 - 5 CUSTOMER TO SUPPLY CIRCUIT BREAKER OR FUSED BRANCH CIRCUIT DISCONNECT (SAFETY) SWITCHES WITH LAG TYPE FUSES FROM POWER SOURCE TO MACHINE. A SEPARATE GROUND WIRE MUST BE CONNECTED FROM DISCONNECT TO EQUIPMENT.
 - 4 BASELINE "Z" IS THE REFERENCE FOR ALL VERTICAL DIMENSIONS. ON MACHINES WITH FIXED BASE PADS, BASELINE "Z" CORRESPONDS TO THE BOTTOM OF THE BASE PAD. ON MACHINES WITH ADJUSTABLE FEET, BASELINE "Z" CORRESPONDS TO THE BOTTOM OF THE FEET WHEN ADJUSTED SO THAT THE MACHINE IS AT ITS MINIMUM ACCEPTABLE HEIGHT. ON TRAVELING SHUTTLES, BASELINE "Z" CORRESPONDS TO THE BOTTOM OF THE BOTTOM RAIL. THE DISTANCE BETWEEN BASELINE "Z" AND THE FINISHED FLOOR WILL VARY AS REQUIRED TO ENSURE BASELINE "Z" IS HORIZONTAL AND ANY INTERFACING MACHINES REQUIRING GROUT ARE SET ON A MINIMUM 1 [25] THICK GROUT BED.
 - 3 USE REFERENCE LINES "X", "Y", AND "Z" TO LOCATE ALL SERVICE CONNECTIONS.
 - 2 NUMBERS IN BRACKETS [] DENOTE DIMENSIONS IN MILLIMETERS.
 - 1 ALL DIMENSIONS SHOWN ARE APPROXIMATE, SUBJECT TO NORMAL MANUFACTURING TOLERANCES, AND TO OCCASIONAL CHANGES WITHOUT NOTICE THROUGH REDESIGN AND/OR RELOCATION OF COMPONENTS, ETC. DO NOT USE FOR CONSTRUCTION UNLESS CERTIFIED, AND IN NO EVENT PRE-PIPE CLOSER THAN FIVE FEET FROM MACHINE. FACTORY MUST BE CONSULTED FOR DIMENSIONS IF MACHINE IS TO BE MOVED THROUGH NARROW OR LOW CORRIDORS OR OPENINGS.

ATTENTION
MOST REGULATORY AUTHORITIES (INCLUDING OSHA IN THE USA) HOLD THE OWNER/USER ULTIMATELY RESPONSIBLE TO MAINTAIN A SAFE WORKING ENVIRONMENT. ACCORDINGLY, THE OWNER/USER MUST RECOGNIZE ALL FORESEEABLE SAFETY HAZARDS, FURNISH SAFETY INSTRUCTIONS AND GUIDANCE TO ALL PERSONNEL WHO MAY COME IN CONTACT WITH THE INSTALLATION, AND PROVIDE ALL NECESSARY ADDITIONAL SAFETY GUARDS, FENCES, RESTRAINTS, DEVICES, ETC., NOT FURNISHED BY THE EQUIPMENT MANUFACTURER OR VENDOR.

ATTENTION
THE FLOOR AND/OR OTHER SUPPORT COMPONENTS MUST HAVE SUFFICIENT STRENGTH (AND RIGIDITY WITH DUE CONSIDERATION FOR NATURAL OR RESONANT FREQUENCY THEREOF) TO WITHSTAND THE FULLY LOADED WEIGHT OF THE MACHINE INCLUDING THE GOODS, THE WATER, AND ANY REPEATED SINUSOIDAL (ROTATING) FORCES GENERATED DURING ITS OPERATION. WRITE THE FACTORY FOR ADDITIONAL MACHINE DATA FOR USE BY A COMPETENT SOIL AND/OR STRUCTURAL ENGINEER.

DRAIN TROUGH 9248G4 PF TUNNEL

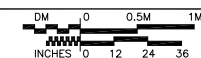

DWG# BDPF92G4DTDDDE
2018125D

MILNOR PELLERIN MILNOR CORPORATION
P.O. Box 400 Kenner, LA 70063, USA, Phone 504/467-9591,
FAX 504/469-1849, Email: milnorinfo@milnor.com

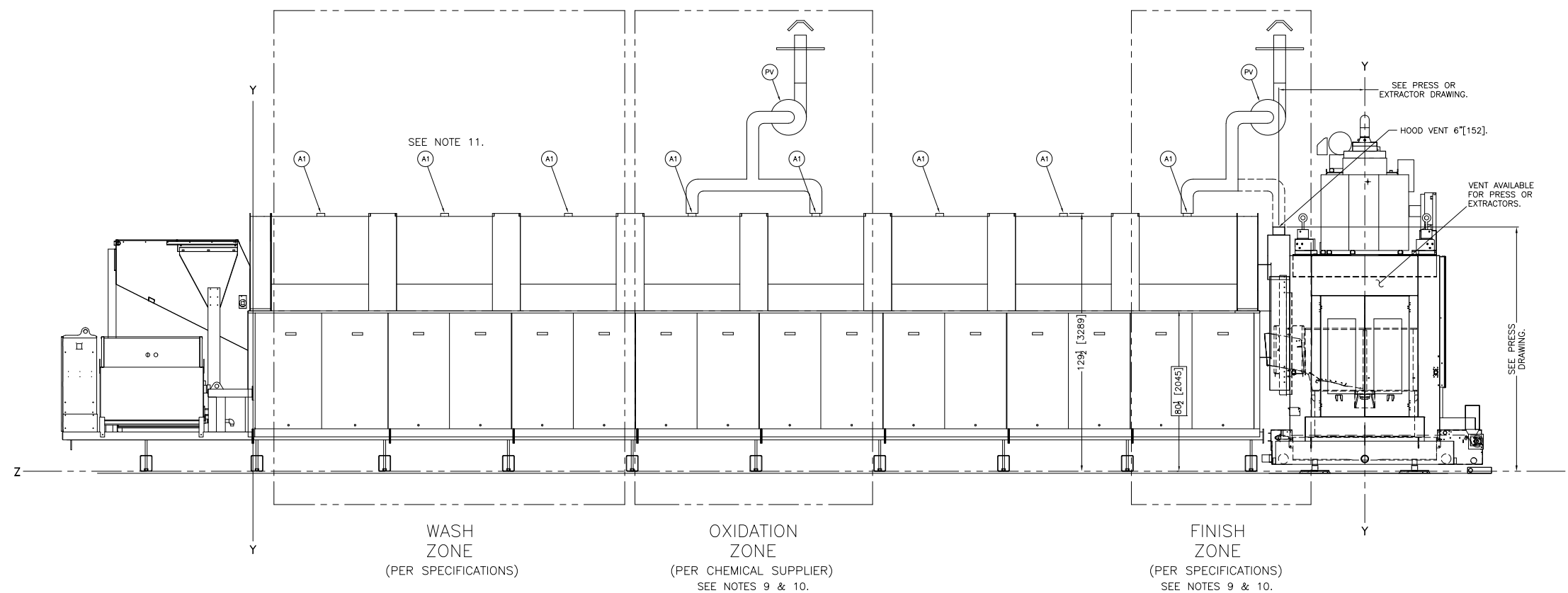

RECOMMENDED VENT SYSTEM FOR THE 9248G4 TUNNEL WASHER AND ADJACENT PRESS

PV	POWERED VENTILATOR & PIPING BY OTHERS, SEE NOTE 10.
A1	VENT, 4[102] DIAMETER. SEE NOTES 8, 9 & 10.
ITEM	LEGEND

- NOTES**
- IT IS NOT RECOMMENDED TO CONNECT MODULE VENTS AHEAD OF THE OXIDATION ZONE TO THE POWER VENT SYSTEM. IF THIS IS NEEDED, ADD 200 TO 250 SCFM OF POWERED VENTILATION PER ADDITIONAL MODULE VENTED.
 - THE BEST PRACTICE IS TO PROVIDE TWO SEPARATE, POWERED VENTILATION UNITS THAT MEET THE FOLLOWING CONDITIONS:
 - THE TWO UNITS ARE ISOLATED FROM EACH OTHER TO AVOID HARMFUL CHEMICAL REACTIONS.
 - VENTILATION FANS HAVE SUFFICIENT POWER TO DRAW VAPORS AWAY FROM THE EQUIPMENT. MILNOR RECOMMENDS:
 - OXIDATION ZONE: 600-750 SCFM (300 TO 375 PER CONNECTION POINT, IF TWO MODULES)
 - FINISH ZONE PLUS THE PRESS ENCLOSURE: 600-750 SCFM (200 TO 250 SCFM PER CONNECTION POINT, IF TWO MODULES PLUS THE PRESS).
 THE SCFM VALUES ARE BASED ON AMBIENT AIR TEMPERATURE OF 68°F(20°C) AND A MINIMAL RELATIVE HUMIDITY.
 - FAN MOTORS ARE EQUIPPED WITH AN ALARM (EXAMPLE: INDICATOR LIGHT) TO ALERT PERSONNEL IF A MOTOR FAILS.
 - FOR TUNNELS WITH LESS THAN SEVEN MODULES, CONSULT MILNOR FACTORY.
 - VAPORS GENERATED IN THE OXIDATION ZONE AND THE FINISH ZONE OF THE TUNNEL CAN MIX TOGETHER, PRODUCE NOXIOUS GASSES, AND CORRODE EQUIPMENT. WITHOUT ADEQUATE VENTILATION, THESE VAPORS WILL EXIT THE TUNNEL, DISCHARGE RING OR CONCENTRATE IN THE DISCHARGE END OF THE TUNNEL AND ADJACENT PRESS ENCLOSURE. THE SEVERITY VARIES WITH CHEMICAL COMPOSITION AND USAGE, BUT CORROSION CAN BE RAPID AND SEVERE.
 - ALL VENTS ARE CAPPED FOR SHIPMENT. UNCAP ALL VENTS AT INSTALLATION.
 - SEE INDIVIDUAL DIMENSIONAL DRAWINGS FOR ADDITIONAL DIMENSIONS FOR ALL MACHINES, INCLUDING HEIGHT. MATCH THIS DRAWING WITH THE INDIVIDUAL MACHINE DIMENSIONAL DRAWINGS USING REFERENCE LINE "Y" AND BASELINE "Z".
 - AS OF THIS WRITING, THE MINIMUM CLEARANCE REQUIRED BY U.S. NATIONAL ELECTRIC CODES, FROM ELECTRIC BOX TO ANY OBJECT IS:
 - 36 [914] IF OBJECT IS AN UNGROUNDED (INSULATED) WALL
 - 42 [1067] IF OBJECT IS A GROUNDED WALL (ie. BARE CONCRETE, BRICK, ETC.)
 - 48 [1219] IF OBJECT IS ANY LIVE PART.
 CHECK LOCAL ELECTRIC CODES FOR FURTHER RESTRICTIONS.
 - CUSTOMER TO SUPPLY CIRCUIT BREAKER OR FUSED BRANCH CIRCUIT DISCONNECT (SAFETY) SWITCHES WITH LAG TYPE FUSES FROM POWER SOURCE TO MACHINE. A SEPARATE GROUND WIRE MUST BE CONNECTED FROM DISCONNECT TO EQUIPMENT.
 - BASELINE "Z" IS THE REFERENCE FOR ALL VERTICAL DIMENSIONS. ON MACHINES WITH FIXED BASE PADS, BASELINE "Z" CORRESPONDS TO THE BOTTOM OF THE BASE PAD. ON MACHINES WITH ADJUSTABLE FEET, BASELINE "Z" CORRESPONDS TO THE BOTTOM OF THE FEET WHEN ADJUSTED SO THAT THE MACHINE IS AT ITS MINIMUM ACCEPTABLE HEIGHT. ON TRAVERSING SHUTTLES, BASELINE "Z" CORRESPONDS TO THE BOTTOM OF THE BOTTOM RAIL. THE DISTANCE BETWEEN BASELINE "Z" AND THE FINISHED FLOOR WILL VARY AS REQUIRED TO ENSURE BASELINE "Z" IS HORIZONTAL AND ANY INTERFACING MACHINES REQUIRING GROUT ARE SET ON A MINIMUM 1[25] THICK GROUT BED.
 - USE REFERENCE LINES "X", "Y", AND "Z" TO LOCATE ALL SERVICE CONNECTIONS.
 - NUMBERS IN BRACKETS [] DENOTE DIMENSIONS IN MILLIMETERS.
 - ALL DIMENSIONS SHOWN ARE APPROXIMATE, SUBJECT TO NORMAL MANUFACTURING TOLERANCES, AND TO OCCASIONAL CHANGES WITHOUT NOTICE THROUGH REDESIGN AND/OR RELOCATION OF COMPONENTS, ETC. DO NOT USE FOR CONSTRUCTION UNLESS CERTIFIED, AND IN NO EVENT PRE-PIPE CLOSER THAN FIVE FEET FROM MACHINE. FACTORY MUST BE CONSULTED FOR DIMENSIONS IF MACHINE IS TO BE MOVED THROUGH NARROW OR LOW CORRIDORS OR OPENINGS.
- ATTENTION**
- MOST REGULATORY AUTHORITIES (INCLUDING OSHA IN THE USA) HOLD THE OWNER/USER ULTIMATELY RESPONSIBLE TO MAINTAIN A SAFE WORKING ENVIRONMENT. ACCORDINGLY, THE OWNER/USER MUST RECOGNIZE ALL FORESEEABLE SAFETY HAZARDS, FURNISH SAFETY INSTRUCTIONS AND GUIDANCE TO ALL PERSONNEL WHO MAY COME IN CONTACT WITH THE INSTALLATION, AND PROVIDE ALL NECESSARY ADDITIONAL SAFETY GUARDS, FENCES, RESTRAINTS, DEVICES, ETC., NOT FURNISHED BY THE EQUIPMENT MANUFACTURER OR VENDOR.
- ATTENTION**
- THE FLOOR AND/OR OTHER SUPPORT COMPONENTS MUST HAVE SUFFICIENT STRENGTH (AND RIGIDITY WITH DUE CONSIDERATION FOR NATURAL OR RESONANT FREQUENCY THEREOF) TO WITHSTAND THE FULLY LOADED WEIGHT OF THE MACHINE INCLUDING THE GOODS, THE WATER, AND ANY REPEATED SINUSOIDAL (ROTATING) FORCES GENERATED DURING ITS OPERATION. WRITE THE FACTORY FOR ADDITIONAL MACHINE DATA FOR USE BY A COMPETENT SOIL AND/OR STRUCTURAL ENGINEER.

9248G4 PF - VENTING

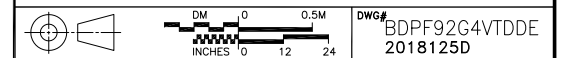

MILNOR PELLERIN MILNOR CORPORATION
 P.O. Box 400 Kenner, LA 70063, USA, Phone 504/467-9591,
 FAX 504/468-3094, Email: milnorinfo@milnor.com

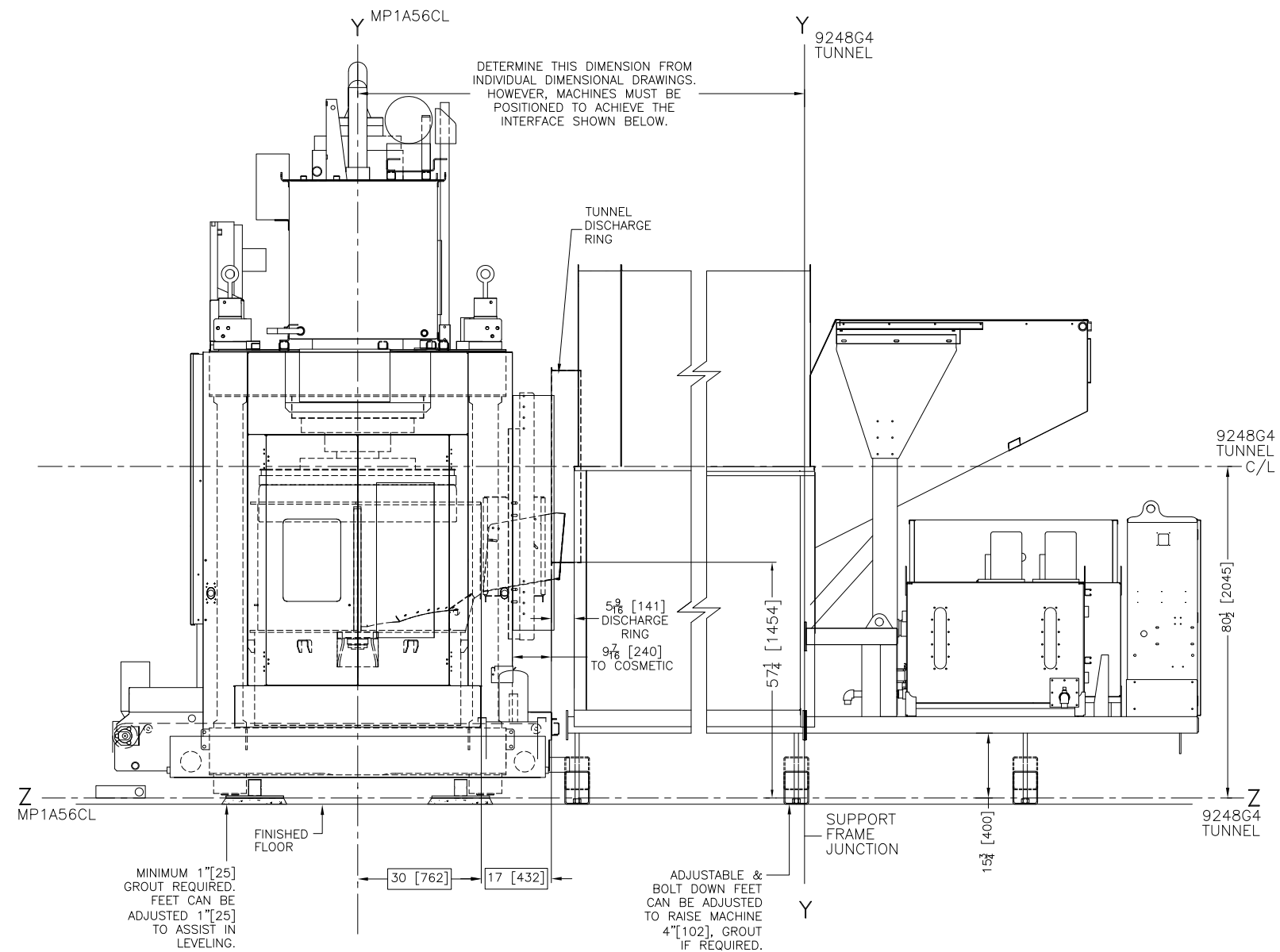
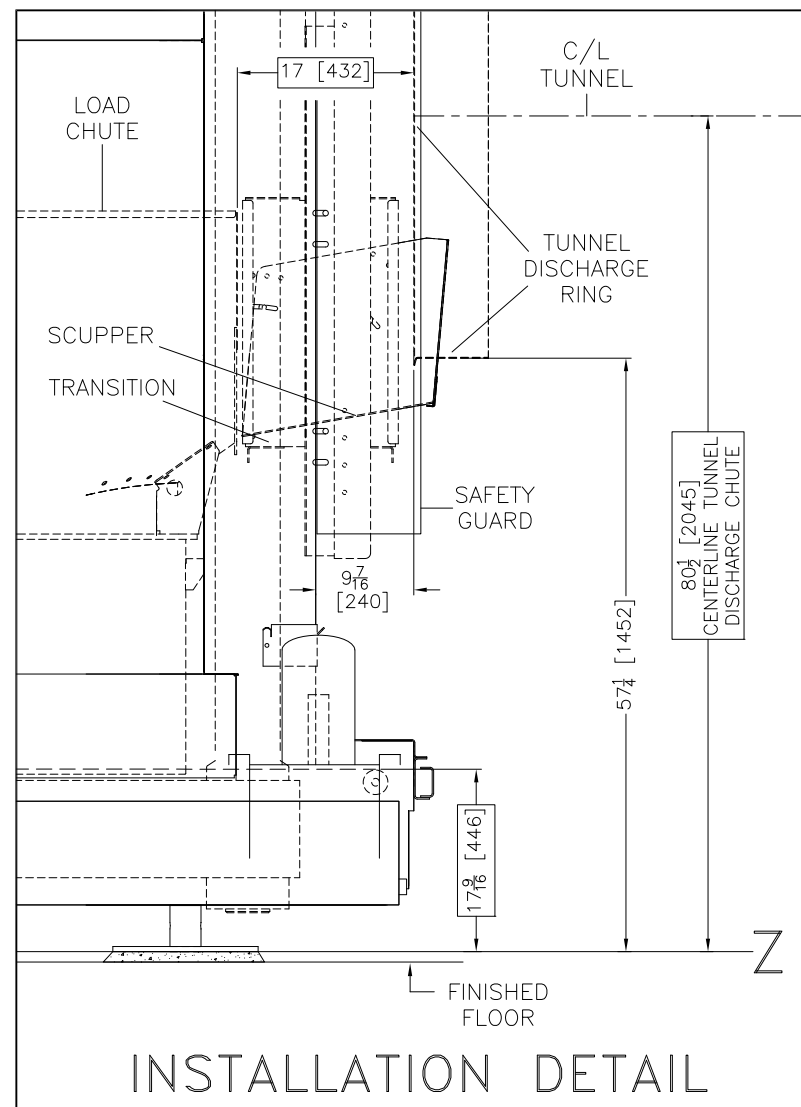

MP1A56CL SINGLE STAGE PRESS/9248G4 TUNNEL

NOTES

- 7 SEE INDIVIDUAL DIMENSIONAL DRAWINGS FOR ADDITIONAL DIMENSIONS FOR ALL MACHINES, INCLUDING HEIGHT. MATCH THIS DRAWING WITH THE INDIVIDUAL MACHINE DIMENSIONAL DRAWINGS USING REFERENCE LINE "Y" AND BASELINE "Z".
- 6 AS OF THIS WRITING, THE MINIMUM CLEARANCE REQUIRED BY U.S. NATIONAL ELECTRIC CODES, FROM ELECTRIC BOX TO ANY OBJECT IS:
 36 [914] IF OBJECT IS AN UNGROUNDED (INSULATED) WALL
 42 [1067] IF OBJECT IS A GROUNDED WALL (ie. BARE CONCRETE, BRICK, ETC.)
 48 [1219] IF OBJECT IS ANY LIVE PART.
 CHECK LOCAL ELECTRIC CODES FOR FURTHER RESTRICTIONS.
- 5 CUSTOMER TO SUPPLY CIRCUIT BREAKER OR FUSED BRANCH CIRCUIT DISCONNECT (SAFETY) SWITCHES WITH LAG TYPE FUSES FROM POWER SOURCE TO MACHINE. A SEPARATE GROUND WIRE MUST BE CONNECTED FROM DISCONNECT TO EQUIPMENT.
- 4 BASELINE "Z" IS THE REFERENCE FOR ALL VERTICAL DIMENSIONS. ON MACHINES WITH FIXED BASE PADS, BASELINE "Z" CORRESPONDS TO THE BOTTOM OF THE BASE PAD. ON MACHINES WITH ADJUSTABLE FEET, BASELINE "Z" CORRESPONDS TO THE BOTTOM OF THE FEET WHEN ADJUSTED SO THAT THE MACHINE IS AT ITS MINIMUM ACCEPTABLE HEIGHT. ON TRAVELING SHUTTLES, BASELINE "Z" CORRESPONDS TO THE BOTTOM OF THE BOTTOM RAIL. THE DISTANCE BETWEEN BASELINE "Z" AND THE FINISHED FLOOR WILL VARY AS REQUIRED TO ENSURE BASELINE "Z" IS HORIZONTAL AND ANY INTERFACING MACHINES REQUIRING GROUT ARE SET ON A MINIMUM 1" [25] THICK GROUT BED.
- 3 USE REFERENCE LINES "X", "Y", AND "Z" TO LOCATE ALL SERVICE CONNECTIONS.
- 2 NUMBERS IN BRACKETS [] DENOTE DIMENSIONS IN MILLIMETERS.
- 1 ALL DIMENSIONS SHOWN ARE APPROXIMATE, SUBJECT TO NORMAL MANUFACTURING TOLERANCES, AND TO OCCASIONAL CHANGES WITHOUT NOTICE THROUGH REDESIGN AND/OR RELOCATION OF COMPONENTS, ETC. DO NOT USE FOR CONSTRUCTION UNLESS CERTIFIED, AND IN NO EVENT PRE-PIPE CLOSER THAN FIVE FEET FROM MACHINE. FACTORY MUST BE CONSULTED FOR DIMENSIONS IF MACHINE IS TO BE MOVED THROUGH NARROW OR LOW CORRIDORS OR OPENINGS.

ATTENTION

MOST REGULATORY AUTHORITIES (INCLUDING OSHA IN THE USA) HOLD THE OWNER/USER ULTIMATELY RESPONSIBLE TO MAINTAIN A SAFE WORKING ENVIRONMENT. ACCORDINGLY, THE OWNER/USER MUST RECOGNIZE ALL FORESEEABLE SAFETY HAZARDS, FURNISH SAFETY INSTRUCTIONS AND GUIDANCE TO ALL PERSONNEL WHO MAY COME IN CONTACT WITH THE INSTALLATION, AND PROVIDE ALL NECESSARY ADDITIONAL SAFETY GUARDS, FENCES, RESTRAINTS, DEVICES, ETC., NOT FURNISHED BY THE EQUIPMENT MANUFACTURER OR VENDOR.

ATTENTION

THE FLOOR AND/OR OTHER SUPPORT COMPONENTS MUST HAVE SUFFICIENT STRENGTH (AND RIGIDITY WITH DUE CONSIDERATION FOR NATURAL OR RESONANT FREQUENCY THEREOF) TO WITHSTAND THE FULLY LOADED WEIGHT OF THE MACHINE INCLUDING THE GOODS, THE WATER, AND ANY REPEATED SINUSOIDAL (ROTATING) FORCES GENERATED DURING ITS OPERATION. WRITE THE FACTORY FOR ADDITIONAL MACHINE DATA FOR USE BY A COMPETENT SOIL AND/OR STRUCTURAL ENGINEER.

9248G4 PF INTERFACE/MP1A56CL

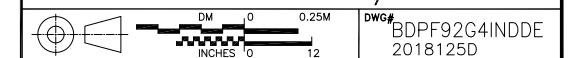

MILNOR PELLERIN MILNOR CORPORATION
 P.O. Box 400 Kenner, LA 70063, USA, Phone 504/467-9591,
 FAX 504/468-3094, Email: milnorinfo@milnor.com

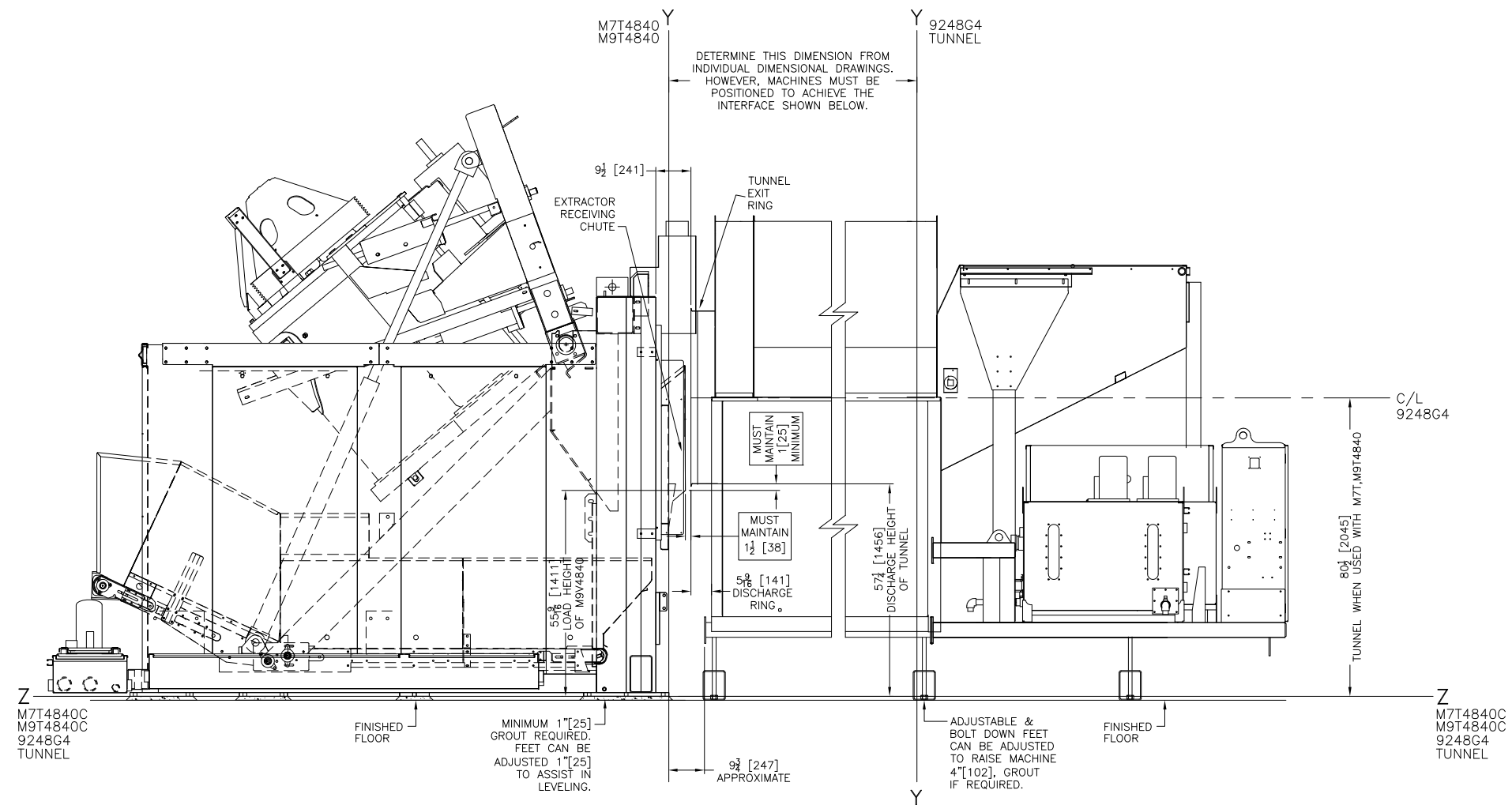

M7T, M9T4840 EXTRACTOR/9248G4 TUNNEL

- NOTES**
- SEE INDIVIDUAL DIMENSIONAL DRAWINGS FOR ADDITIONAL DIMENSIONS FOR ALL MACHINES, INCLUDING HEIGHT. MATCH THIS DRAWING WITH THE INDIVIDUAL MACHINE DIMENSIONAL DRAWINGS USING REFERENCE LINE "Y" AND BASELINE "Z".
 - AS OF THIS WRITING, THE MINIMUM CLEARANCE REQUIRED BY U.S. NATIONAL ELECTRIC CODES, FROM ELECTRIC BOX TO ANY OBJECT IS:
 36 [914] IF OBJECT IS AN UNGROUNDED (INSULATED) WALL.
 42 [1067] IF OBJECT IS A GROUNDED WALL (i.e. BARE CONCRETE, BRICK, ETC.).
 48 [1219] IF OBJECT IS ANY LIVE PART.
 CHECK LOCAL ELECTRIC CODES FOR FURTHER RESTRICTIONS.
 - CUSTOMER TO SUPPLY CIRCUIT BREAKER OR FUSED BRANCH CIRCUIT DISCONNECT (SAFETY) SWITCHES WITH LAG-TYPE FUSES FROM POWER SOURCE TO MACHINE. A SEPARATE GROUND WIRE MUST BE CONNECTED FROM DISCONNECT TO EQUIPMENT.
 - BASELINE "Z" IS THE REFERENCE FOR ALL VERTICAL DIMENSIONS. ON MACHINES WITH FIXED BASE PADS, BASELINE "Z" CORRESPONDS TO THE BOTTOM OF THE BASE PAD. ON MACHINES WITH ADJUSTABLE FEET, BASELINE "Z" CORRESPONDS TO THE BOTTOM OF THE FEET WHEN ADJUSTED SO THAT THE MACHINE IS AT ITS MINIMUM ACCEPTABLE HEIGHT. ON TRAVELING SHUTTLES, BASELINE "Z" CORRESPONDS TO THE BOTTOM OF THE BOTTOM RAIL. THE DISTANCE BETWEEN BASELINE "Z" AND THE FINISHED FLOOR WILL VARY AS REQUIRED TO ENSURE BASELINE "Z" IS HORIZONTAL AND ANY INTERFACING MACHINES REQUIRING GROUT ARE SET ON A MINIMUM 1" [25] THICK GROUT BED.
 - USE REFERENCE LINES "X", "Y", AND "Z" TO LOCATE ALL SERVICE CONNECTIONS.
 - NUMBERS IN BRACKETS [] DENOTE DIMENSIONS IN MILLIMETERS.
 - ALL DIMENSIONS SHOWN ARE APPROXIMATE, SUBJECT TO NORMAL MANUFACTURING TOLERANCES, AND TO OCCASIONAL CHANGES WITHOUT NOTICE THROUGH REDESIGN AND/OR RELOCATION OF COMPONENTS, ETC. DO NOT USE FOR CONSTRUCTION UNLESS CERTIFIED, AND IN NO EVENT PRE-PIPE CLOSER THAN FIVE FEET FROM MACHINE. FACTORY MUST BE CONSULTED FOR DIMENSIONS IF MACHINE IS TO BE MOVED THROUGH NARROW OR LOW CORRIDORS OR OPENINGS.
- ATTENTION**
 MOST REGULATORY AUTHORITIES (INCLUDING OSHA IN THE USA) HOLD THE OWNER/USER ULTIMATELY RESPONSIBLE TO MAINTAIN A SAFE WORKING ENVIRONMENT. ACCORDINGLY, THE OWNER/USER MUST RECOGNIZE ALL FORESEEABLE SAFETY HAZARDS, FURNISH SAFETY INSTRUCTIONS AND GUIDANCE TO ALL PERSONNEL WHO MAY COME IN CONTACT WITH THE INSTALLATION, AND PROVIDE ALL NECESSARY ADDITIONAL SAFETY GUARDS, FENCES, RESTRAINTS, DEVICES, ETC., NOT FURNISHED BY THE EQUIPMENT MANUFACTURER OR VENDOR.
- ATTENTION**
 THE FLOOR AND/OR OTHER SUPPORT COMPONENTS MUST HAVE SUFFICIENT STRENGTH (AND RIGIDITY WITH DUE CONSIDERATION FOR NATURAL OR RESONANT FREQUENCY THEREOF) TO WITHSTAND THE FULLY LOADED WEIGHT OF THE MACHINE INCLUDING THE GOODS, THE WATER, AND ANY REPEATED SINUSOIDAL (ROTATING) FORCES GENERATED DURING ITS OPERATION. WRITE THE FACTORY FOR ADDITIONAL MACHINE DATA FOR USE BY A COMPETENT SOIL AND/OR STRUCTURAL ENGINEER.

9248G4 PF INTERFACE/M9T4840

DM 0 0.5M DWG# BDPF92G4INDDB
 INCHES 0 12 24 2018125D

MILNOR PELLERIN MILNOR CORPORATION
 P.O. Box 400 Kenner, LA 70063, USA, Phone 504/467-9591,
 FAX 504/468-3094, Email: milnorinfo@milnor.com