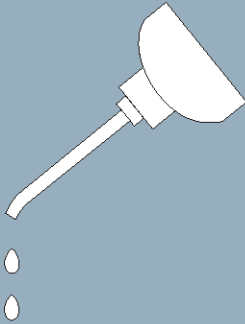


Published Manual Number/ECN: MPIM9T48BE/2022146A

- Publishing System: TPAS2
- Access date: 04/06/2022
- Document ECNs: Latest



**Read the
separate
safety
manual
before
installing,
operating,
or servicing**

Service & Mechanical Parts

Centrifugal Extractors

M7T4836C, M7T4840C

M9T4836C, M9T4840C

and Extractor Conveyors

Table of Contents

MPIM9T48BE/22146A

Page	Description	Document
1	Limited Standard Warranty	BMP720097/2019036
2	How to Get the Necessary Repair Components	BIUUUD19/20081231
3	Trademarks	BNUUUU02/2021104A
4	Safety—Centrifugal Extractor	BIUUUS27PE/20051111
10	SAFETY ALERT for Owner/Managers and Maintenance Personnel: Using the Access Panel Interlock Bypass Key Switch	BICP1S01AB/20060111
11	Use the Red Safety Supports for Maintenance —M7T48_, M9T48_	BNE48H01/2021344
13	Permanent Safety Stands - M7V4840C, M7V4836C	BPE48K01/2021355A
15	1. Installation	
16	Handling and Setting Centrifugal Extractors	MSINA406AE/199436AV
21	Centrifugal Extractor Service Connections	MSIN0906AE/199438AV
25	About the Forces Transmitted by Milnor® Washer-extractors	BIWUUI02/20001108
27	Understanding Tag Guidelines	BIUUUI02PE/20160712
30	Safety Placard Use and Placement: M9V,MXS4232 & M9V4840	BMP030013/2013342B
32	Safety Placard Use and Placement ISO: MXS/M9V4232 & M9V4840	BMP030014/2013342B
34	Guards & Covers	BMP050057/2005205V
36	Shipping Brackets	BMP050045/2005255V
38	Pull-wire Stop Switch	BMP140053/2017336A
41	2. Service and Maintenance	
42	Centrifugal Extractor Preventive Maintenance	BIPV7M01/20040324
52	Motor Maintenance	BIUUUM03/2011433A
56	Torque Requirements for Fasteners	BIUUUM04/20180109
64	Disc Brake Maintenance	BIEUUM01/2012266A
76	Servicing Air Cylinders	MSSM0130AE/199313AV
78	Conveyor Lubrication & Chain Adjustments	BMP070001/2007042B
80	Conveyor Adjustment Procedures	BMP820015/1996322V
83	Installing Anti-Friction Strips	MSINC402AE/1986361N
84	Inclined Storage Conveyor Assembly Instructions	MSIND422AE/1986462N
89	2.1. Drive Assemblies	
90	Drive Chart M9T4836C, M9T4840C	BMP050039/2018444A
92	Drive Motor Installation M9T4840C, M9T4836C	BMP180062/2018444A
94	Disc Brake M9T4840C, M9T4836C	BMP180063/2018444A
97	Bearing Assembly M9T4840C, M9T4836C	BMP180064/2018444A
101	Shell, Cylinder, Bearing, & Pulley Installation M9T4840C, M9T4836C	BMP180061/2018444B

Table of Contents, continued

MPIM9T48BE/22146A

Page	Description	Document
103	Cylinders and Cotton Mod Piping	BMP050031/2022146B
107	Inflatable Rib Assembly	BMP110048/2019174A
109	2.2. Frame, Pivots and Suspension	
110	Pivot Ball Bushing Assembly	BMP050042/2005105V
113	Suspension Hydrocushion Cylinder Installation	BMP050040/2005105V
115	Hydrocushion Cylinders	BMP050041/2005255V
117	Tilt Stops	BMP050043/2005105V
119	2.3. Shell and Door Assemblies	
120	Shellfront Installation	BMP050056/2005255V
122	Load Chute Assembly	BMP050047/2005105V
125	Air Cylinder 2-Way	BMP050058/2008105B
127	2.4. Hydraulic Devices	
128	Hydraulic Schematic	BMP050060/2013342B
129	Hydraulic Tank	BMP050035/2005105V
135	Hydraulic Hoses & Piping	BMP050037/2019153A
139	Hydraulic Tilt Cylinders	BMP050036/2013355A
141	Assuring Proper Counterbalance Valve Operation-Hydraulic Tilting Washer-Extractors and Centrifugal Extractors	BIPEUM01/20110414
145	2.5. Conveyor & Reuse Tank	
146	Extractor Conveyor with Side Drain 25 Degree Discharge CETE0025, CETE2425, CETE4825 for M9T4840	BMP180060/2018444A
155	Side Drain Door Assembly	BMP180065/2018444A
156	Reuse Tank & Level Switch	BMP050046/2005106V
159	2.6. Pneumatic Piping and Assemblies	
160	Pneumatic Schematic	BMP050061/2008094B
162	Air Cylinder Brake Assembly	BMP020038/2002226V
165	2.7. Control and Sensing Assemblies	
166	Sensors	BMP050059/2005255V
168	Excursion Switch	BMP050044/2005105V
169	2.8. Dimensional Drawings	
171	Dimensional Drawing - M7T4840C, M7T4836, M9T4840C, M7T4836C	BDM9T4840CAE/2017044D
172	Dimensional Drawing - M7T4840C, M7T4836, M9T4840C, M7T4836C Options	BDM9T4840CAB/2017044D
173	Dimensional Drawing - M7T/M9T4840 Drain Trough	BDM9T48DRNAE/2017065D
174	Dimensional Drawing - COBUD-EH & 9248G4 Drain Trough	BDCOBUDEHDBE/2012235D

PELLERIN MILNOR CORPORATION

LIMITED STANDARD WARRANTY

We warrant to the original purchaser that MILNOR machines including electronic hardware/software (hereafter referred to as "equipment"), will be free from defects in material and workmanship for a period of one year from the date of shipment (unless the time period is specifically extended for certain parts pursuant to a specific MILNOR published extended warranty) from our factory with no operating hour limitation. This warranty is contingent upon the equipment being installed, operated and serviced as specified in the operating manual supplied with the equipment, and operated under normal conditions by competent operators.

Providing we receive written notification of a warranted defect within 30 days of its discovery, we will—at our option—repair or replace the defective part or parts, EX Factory (labor and freight specifically NOT included). We retain the right to require inspection of the parts claimed defective in our factory prior to repairing or replacing same. We will not be responsible, or in any way liable, for unauthorized repairs or service to our equipment, and this warranty shall be void if the equipment is tampered with, modified, or abused, used for purposes not intended in the design and construction of the machine, or is repaired or altered in any way without MILNOR's written consent.

Parts damaged by exposure to weather, to aggressive water, or to chemical attack are not covered by this warranty. For parts which require routine replacement due to normal wear—such as gaskets, contact points, brake and clutch linings, belts, hoses, and similar parts—the warranty time period is 90 days.

We reserve the right to make changes in the design and/or construction of our equipment (including purchased components) without obligation to change any equipment previously supplied.

ANY SALE OR FURNISHING OF ANY EQUIPMENT BY MILNOR IS MADE ONLY UPON THE EXPRESS UNDERSTANDING THAT MILNOR MAKES NO EXPRESSED OR IMPLIED WARRANTIES OF MERCHANTABILITY OR FITNESS FOR ANY PARTICULAR USE OR PURPOSE OR ANY OTHER WARRANTY IMPLIED BY LAW INCLUDING BUT NOT LIMITED TO REDHIBITION. MILNOR WILL NOT BE RESPONSIBLE FOR ANY COSTS OR DAMAGES ACTUALLY INCURRED OR REQUIRED AS A RESULT OF: THE FAILURE OF ANY OTHER PERSON OR ENTITY TO PERFORM ITS RESPONSIBILITIES, FIRE OR OTHER HAZARD, ACCIDENT, IMPROPER STORAGE, MIS-USE, NEGLIGENCE, POWER OR ENVIRONMENTAL CONTROL MALFUNCTIONS, DAMAGE FROM LIQUIDS, OR ANY OTHER CAUSE BEYOND THE NORMAL RANGE OF USE. REGARDLESS OF HOW CAUSED, IN NO EVENT SHALL MILNOR BE LIABLE FOR SPECIAL, INDIRECT, PUNITIVE, LIQUIDATED, OR CONSEQUENTIAL COSTS OR DAMAGES, OR ANY COSTS OR DAMAGES WHATSOEVER WHICH EXCEED THE PRICE PAID TO MILNOR FOR THE EQUIPMENT IT SELLS OR FURNISHES.

THE PROVISIONS ON THIS PAGE REPRESENT THE ONLY WARRANTY FROM MILNOR AND NO OTHER WARRANTY OR CONDITIONS, STATUTORY OR OTHERWISE, SHALL BE IMPLIED.

WE NEITHER ASSUME, NOR AUTHORIZE ANY EMPLOYEE OR OTHER PERSON TO ASSUME FOR US, ANY OTHER RESPONSIBILITY AND/OR LIABILITY IN CONNECTION WITH THE SALE OR FURNISHING OF OUR EQUIPMENT TO ANY BUYER.

BMP720097/19036

How to Get the Necessary Repair Components



This document uses Simplified Technical English.
Learn more at <http://www.asd-ste100.org>.

You can get components to repair your machine from the approved supplier where you got this machine. Your supplier will usually have the necessary components in stock. You can also get components from the Milnor® factory.

Tell the supplier the machine model and serial number and this data for each necessary component:

- The component number from this manual
- The component name if known
- The necessary quantity
- The necessary transportation requirements
- If the component is an electrical component, give the schematic number if known.
- If the component is a motor or an electrical control, give the nameplate data from the used component.

To write to the Milnor factory:

Pellerin Milnor Corporation
Post Office Box 400
Kenner, LA 70063-0400
UNITED STATES

Telephone: 504-467-2787
Fax: 504-469-9777
Email: parts@milnor.com

— End of BIUUUD19 —

Trademarks

These words are trademarks of Pellerin Milnor[®] Corporation and other entities:

Table 1. Trademarks

AutoSpot [™]	GreenFlex [™]	MilMetrix [®]	PulseFlow [®]
CBW [®]	GearTrace [™]	MilTouch [™]	RAM Command [™]
Drynet [™]	GreenTurn [™]	MilTouch-EX [™]	RecircONE [®]
E-P Express [®]	Hydro-cushion [™]	MILRAIL [™]	RinSave [®]
E-P OneTouch [®]	Mentor [®]	Miltrac [™]	SmoothCoil [™]
E-P Plus [®]	Mildata [®]	PBW [™]	Staph Guard [®]
Gear Guardian [®]	Milnor [®]		

End of document: BNUUUU02

Safety—Centrifugal Extractor

1. General Safety Requirements—Vital Information for Management Personnel [Document BIUUUS04]

Incorrect installation, neglected preventive maintenance, abuse, and/or improper repairs, or changes to the machine can cause unsafe operation and personal injuries, such as multiple fractures, amputations, or death. The owner or his selected representative (owner/user) is responsible for understanding and ensuring the proper operation and maintenance of the machine. The owner/user must familiarize himself with the contents of all machine instruction manuals. The owner/user should direct any questions about these instructions to a Milnor® dealer or the Milnor® Service department.

Most regulatory authorities (including OSHA in the USA and CE in Europe) hold the owner/user ultimately responsible for maintaining a safe working environment. Therefore, the owner/user must do or ensure the following:

- recognize all foreseeable safety hazards within his facility and take actions to protect his personnel, equipment, and facility;
- work equipment is suitable, properly adapted, can be used without risks to health or safety, and is adequately maintained;
- where specific hazards are likely to be involved, access to the equipment is restricted to those employees given the task of using it;
- only specifically designated workers carry out repairs, modifications, maintenance, or servicing;
- information, instruction, and training is provided;
- workers and/or their representatives are consulted.

Work equipment must comply with the requirements listed below. The owner/user must verify that installation and maintenance of equipment is performed in such a way as to support these requirements:

- control devices must be visible, identifiable, and marked; be located outside dangerous zones; and not give rise to a hazard due to unintentional operation;
- control systems must be safe and breakdown/damage must not result in danger;
- work equipment is to be stabilized;
- protection against rupture or disintegration of work equipment;
- guarding, to prevent access to danger zones or to stop movements of dangerous parts before the danger zones are reached. Guards to be robust; not give rise to any additional hazards; not be easily removed or rendered inoperative; situated at a sufficient distance from the danger zone; not restrict view of operating cycle; allow fitting, replacing, or maintenance by restricting access to relevant area and without removal of guard/protection device;
- suitable lighting for working and maintenance areas;
- maintenance to be possible when work equipment is shut down. If not possible, then protection measures to be carried out outside danger zones;
- work equipment must be appropriate for preventing the risk of fire or overheating; discharges of gas, dust, liquid, vapor, other substances; explosion of the equipment or substances in it.

- 1.1. **Laundry Facility**—Provide a supporting floor that is strong and rigid enough to support—with a reasonable safety factor and without undue or objectionable deflection—the weight of the fully loaded machine and the forces transmitted by it during operation. Provide sufficient clearance for machine movement. Provide any safety guards, fences, restraints, devices, and verbal and/or posted restrictions necessary to prevent personnel, machines, or other moving machinery from accessing the machine or its path. Provide adequate ventilation to carry away heat and vapors. Ensure service connections to installed machines meet local and national safety standards, especially regarding the electrical disconnect (see the National Electric Code). Prominently post safety information, including signs showing the source of electrical disconnect.
- 1.2. **Personnel**—Inform personnel about hazard avoidance and the importance of care and common sense. Provide personnel with the safety and operating instructions that apply to them. Verify that personnel use proper safety and operating procedures. Verify that personnel understand and abide by the warnings on the machine and precautions in the instruction manuals.
- 1.3. **Safety Devices**—Ensure that no one eliminates or disables any safety device on the machine or in the facility. Do not allow machine to be used with any missing guard, cover, panel or door. Service any failing or malfunctioning device before operating the machine.
- 1.4. **Hazard Information**—Important information on hazards is provided on the machine safety placards, in the Safety Guide, and throughout the other machine manuals. **Placards must be kept clean so that the information is not obscured. They must be replaced immediately if lost or damaged. The Safety Guide and other machine manuals must be available at all times to the appropriate personnel.** See the machine service manual for safety placard part numbers. Contact the Milnor Parts department for replacement placards or manuals.
- 1.5. **Maintenance**—Ensure the machine is inspected and serviced in accordance with the norms of good practice and with the preventive maintenance schedule. Replace belts, pulleys, brake shoes/disks, clutch plates/tires, rollers, seals, alignment guides, etc. before they are severely worn. Immediately investigate any evidence of impending failure and make needed repairs (e.g., cylinder, shell, or frame cracks; drive components such as motors, gear boxes, bearings, etc., whining, grinding, smoking, or becoming abnormally hot; bending or cracking of cylinder, shell, frame, etc.; leaking seals, hoses, valves, etc.) Do not permit service or maintenance by unqualified personnel.

2. Safety Alert Messages—Internal Electrical and Mechanical Hazards [Document BIUUUS11]

The following are instructions about hazards inside the machine and in electrical enclosures.



WARNING 1: Electrocution and Electrical Burn Hazards—Contact with electric power can kill or seriously injure you. Electric power is present inside the cabinetry unless the main machine power disconnect is off.

- Do not unlock or open electric box doors.
- Do not remove guards, covers, or panels.
- Do not reach into the machine housing or frame.
- Keep yourself and others off of machine.
- Know the location of the main machine disconnect and use it in an emergency to remove all electric power from the machine.



WARNING 2: Entangle and Crush Hazards—Contact with moving components normally isolated by guards, covers, and panels, can entangle and crush your limbs. These components move automatically.

- Do not remove guards, covers, or panels.
- Do not reach into the machine housing or frame.
- Keep yourself and others off of machine.
- Know the location of all emergency stop switches, pull cords, and/or kick plates and use them in an emergency to stop machine motion.



WARNING 3: Crush Hazards—Tilting machines only—The machine housing will crush your body or limbs if it descends or falls while you are under it. Housing can descend with power off or on. Manual operation of tilting valves overrides safety interlocks. Improper operation of manual tilting valves may cause the housing to descend.

- Do not remove guards, covers, or panels.
- Do not reach into the machine housing or frame.

3. Safety Alert Messages—External Mechanical Hazards [Document BIUUUS12]

The following are instructions about hazards around the front, sides, rear or top of the machine.



WARNING 4: Crush Hazards—Suspended machines only—Spaces between the shell and housing can close and crush or pinch your limbs. The shell moves within the housing during operation.

- Do not reach into the machine housing or frame.
- Keep yourself and others clear of movement areas and paths.



WARNING 5: Fall, Entangle, and Strike Hazards—Machine motion can cause you to fall or become entangled in or struck by nearby objects if you stand, walk, or ride on the machine. Shuttles and conveyor belts move automatically.

- Keep yourself and others off of machine.

4. Safety Alert Messages—Cylinder and Processing Hazards

[Document BIUUUS13]

The following are instructions about hazards related to the cylinder and laundering process.



DANGER 6: Entangle and Sever Hazards—Contact with goods being processed can cause the goods to wrap around your body or limbs and dismember you.

- Do not attempt to open the door or reach into the cylinder until the cylinder is stopped.
- Do not touch goods inside or hanging partially outside the turning cylinder.
- Know the location of all emergency stop switches, pull cords, and/or kick plates and use them in an emergency to stop machine motion.
- Know the location of the main machine disconnect and use it in an emergency to remove all electric power from the machine.



WARNING 7: Crush Hazards—Contact with the turning cylinder can crush your limbs. The cylinder will repel any object you try to stop it with, possibly causing the object to strike or stab you.

- Lock out and tag out power at the main machine disconnect before reaching into the cylinder.
- Do not place any object in the turning cylinder.



WARNING 8: Confined Space Hazards—Confinement in the cylinder can kill or injure you. Hazards include but are not limited to panic, burns, poisoning, suffocation, heat prostration, biological contamination, electrocution, and crushing.

- Do not attempt unauthorized servicing, repairs, or modification.



WARNING 9: Explosion and Fire Hazards—Flammable substances can explode or ignite in the cylinder, drain trough, or sewer. The machine is designed for washing with water, not any other solvent. Processing can cause solvent-containing goods to give off flammable vapors.

- Do not use flammable solvents in processing.

5. Safety Alert Messages—Unsafe Conditions [Document BIUUUS14]

5.1. Damage and Malfunction Hazards

5.1.1. Hazards Resulting from Inoperative Safety Devices



WARNING 10: Multiple Hazards—Operating the machine with an inoperative safety device can kill or injure personnel, damage or destroy the machine, damage property, and/or void the warranty.

- Do not tamper with or disable any safety device or operate the machine with a malfunctioning safety device. Request authorized service.



WARNING 11: Electrocution and Electrical Burn Hazards—Electric box doors—Operating the machine with any electric box door unlocked can expose high voltage conductors inside the box.

- Do not unlock or open electric box doors.



WARNING 12: Entangle and Crush Hazards—Guards, covers, and panels—Operating the machine with any guard, cover, or panel removed exposes moving components.

- Do not remove guards, covers, or panels.

5.1.2. Hazards Resulting from Damaged Mechanical Devices



WARNING 13: Multiple Hazards—Operating a damaged machine can kill or injure personnel, further damage or destroy the machine, damage property, and/or void the warranty.

- Do not operate a damaged or malfunctioning machine. Request authorized service.



WARNING 14: Explosion Hazards—Cylinder—A damaged cylinder can rip apart during extraction, puncturing the shell and discharging metal fragments at high speed.

- Do not operate the machine with any evidence of damage or malfunction.

5.2. Careless Use Hazards

5.2.1. Careless Operation Hazards—Vital Information for Operator Personnel (see also operator hazards throughout manual)



WARNING 15: Multiple Hazards—Careless operator actions can kill or injure personnel, damage or destroy the machine, damage property, and/or void the warranty.

- Do not tamper with or disable any safety device or operate the machine with a malfunctioning safety device. Request authorized service.
- Do not operate a damaged or malfunctioning machine. Request authorized service.
- Do not attempt unauthorized servicing, repairs, or modification.
- Do not use the machine in any manner contrary to the factory instructions.
- Use the machine only for its customary and intended purpose.
- Understand the consequences of operating manually.



CAUTION 16: Goods Damage and Wasted Resources—Entering incorrect cake data causes improper processing, routing, and accounting of batches.

- Understand the consequences of entering cake data.

5.2.2. Careless Servicing Hazards—Vital Information for Service Personnel (see also service hazards throughout manuals)



WARNING 17: Electrocutation and Electrical Burn Hazards—Contact with electric power can kill or seriously injure you. Electric power is present inside the cabinetry unless the main machine power disconnect is off.

- Do not service the machine unless qualified and authorized. You must clearly understand the hazards and how to avoid them.
- Abide by the current OSHA lockout/tagout standard when lockout/tagout is called for in the service instructions. Outside the USA, abide by the OSHA standard in the absence of any other overriding standard.



WARNING 18: Entangle and Crush Hazards—Contact with moving components normally isolated by guards, covers, and panels, can entangle and crush your limbs. These components move automatically.

- Do not service the machine unless qualified and authorized. You must clearly understand the hazards and how to avoid them.
- Abide by the current OSHA lockout/tagout standard when lockout/tagout is called for in the service instructions. Outside the USA, abide by the OSHA standard in the absence of any other overriding standard.



WARNING 19: Crush Hazards—Tilting machines only—The machine housing will crush your body or limbs if it descends or falls while you are under it. Housing can descend with power off or on. Manual operation of tilting valves overrides safety interlocks. Improper operation of manual tilting valves may cause the housing to descend.

- Secure both red safety supports in accordance with the instructions furnished, then lock out and tag out power at the main machine disconnect before working under the tilted machine.
- Do not operate the manual tilt valves with anyone under the machine.
- Do not operate the tilt controls with anyone under the machine.



WARNING 20: Confined Space Hazards—Confinement in the cylinder can kill or injure you. Hazards include but are not limited to panic, burns, poisoning, suffocation, heat prostration, biological contamination, electrocution, and crushing.

- Do not enter the cylinder until it has been thoroughly purged, flushed, drained, cooled, and immobilized.

— End of BIUUUS27 —

SAFETY ALERT for Owner/Managers and Maintenance Personnel: Using the Access Panel Interlock Bypass Key Switch

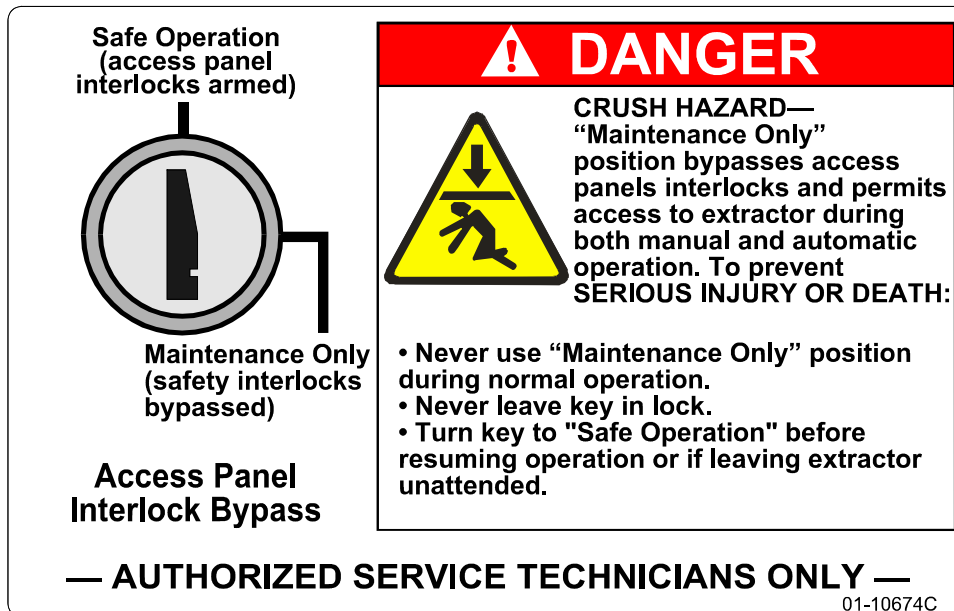
The access panels on this machine are equipped with safety lockout switches that disable the machine if a panel is removed. The Access Panel Interlock Bypass key switch permits bypassing this safety feature to allow access to certain moving parts during required maintenance procedures. This key switch, located inside the low voltage control box, is shown in Figure 1.



DANGER 1: Crush Hazard—The “Maintenance Only” position bypasses access panel interlocks and permits access to moving parts during both manual and automatic operation. **To prevent serious injury or death**, comply with, or ensure compliance with the following:

- **Never use the machine for normal operation with this switch in the “Maintenance Only” position.**
- **Never use this switch to clear faults or for any operational function.**
- **Use this switch *only* if you are a trained, authorized service technician**, and only when performing maintenance that requires immediate access to moving parts normally shielded by the access panels.
- Always turn the switch to the “Safe Operation” position **and remove the key** before resuming normal operation or stepping away from the machine.
- Keep the Access Panel Interlock Bypass key secured away from machine operators and all other personnel who do not fully understand the results of using it.
- Keep all electrical and control cabinets closed and securely latched. Keep control cabinet keys away from untrained employees.

Figure 1: Access Panel Bypass Key Switch and Safety Placard



— End of BICP1S01 —

Use the Red Safety Supports for Maintenance — M7T48_, M9T48_

BNE48H01.C02 0000373962 A.4 A.3 8/17/21 1:08 PM Released

1. What Safety Supports are Provided and Why

BNE48H01.C01 0000373657 A.4 A.6 8/18/21 4:51 PM Released

These machines are provided with two safety stands that are permanently mounted and surround the tilt cylinders. The only action that is necessary to use them is to insert bolts at either of two locations that correspond to the two tilt positions—horizontal or full up. The safety supports provide protection against the drifting down of the vertically moving portion of the machine during maintenance in the event of a leak in the hydraulic system. They are not intended to restrain the machine from coming down under power. Use the safety support(s) whenever the maintenance to be performed requires you to place any part of your body in or near the path of the vertically moving portion of the machine.



WARNING: **Incorrect use of the safety supports** — can cause the machine to descend and crush you.



- ▶ Never work near the path of the vertically moving portion of the machine unless the safety supports are deployed and power is removed from the machine.
- ▶ Do not use power to close a small gap between the machine and the safety supports. Use care not to lower the machine with the safety supports

deployed.

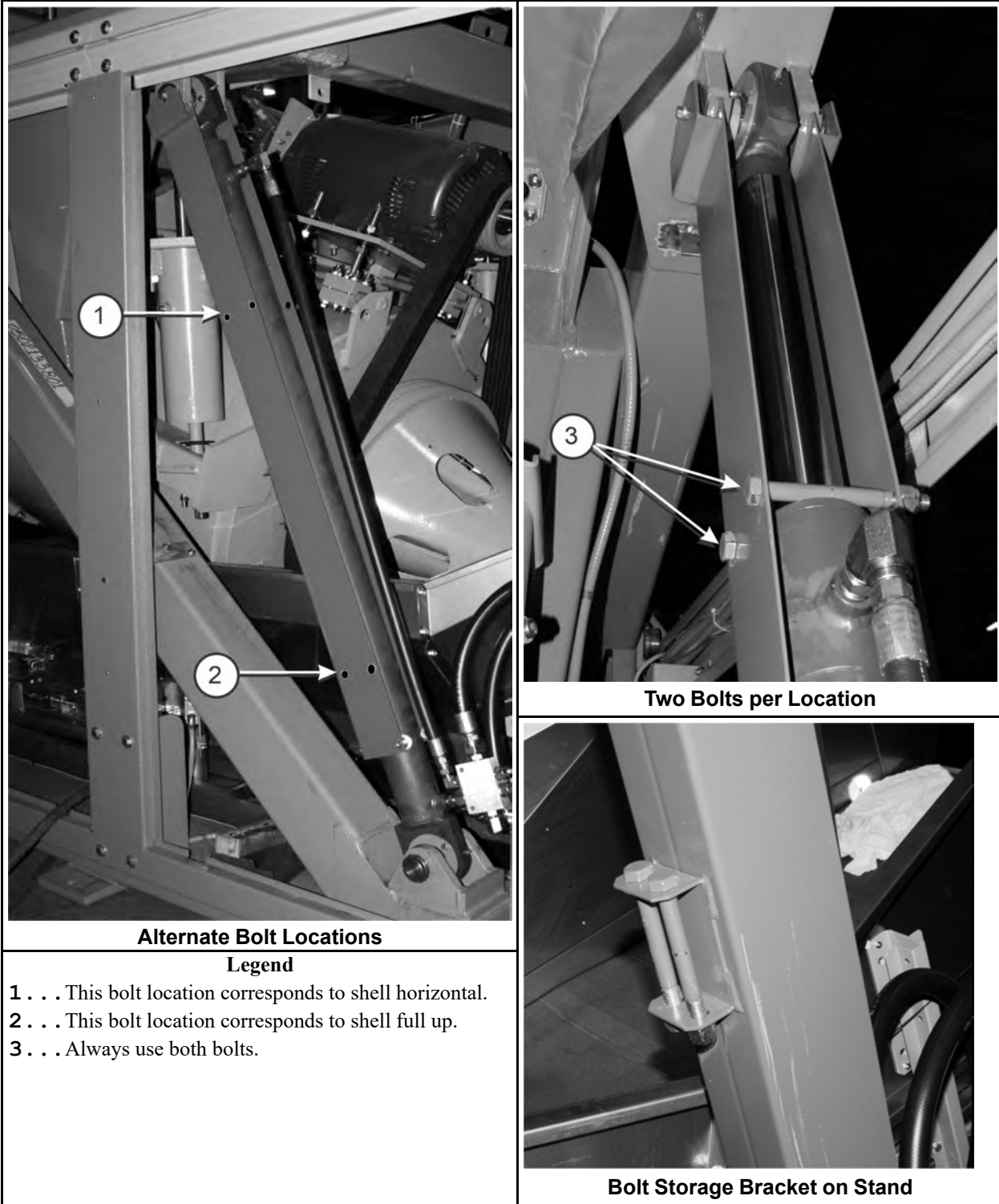
- ▶ Where a pair of safety supports is provided, always use both supports.
- ▶ Maintain the safety support(s) in good condition.

2. How To Deploy the Safety Stands

BNE48H01.T01 0000373961 A.4 A.2 8/12/21 2:06 PM Released

1. Use the Manual mode to raise the shell (drum) to the needed position—horizontal or full up.
2. See the figure below. Install both safety bolts at the appropriate pair of hole locations in each stand. Always use both bolts and nuts on each stand. Return the bolts to their storage brackets when maintenance is completed.

Figure 1. Safety Stands

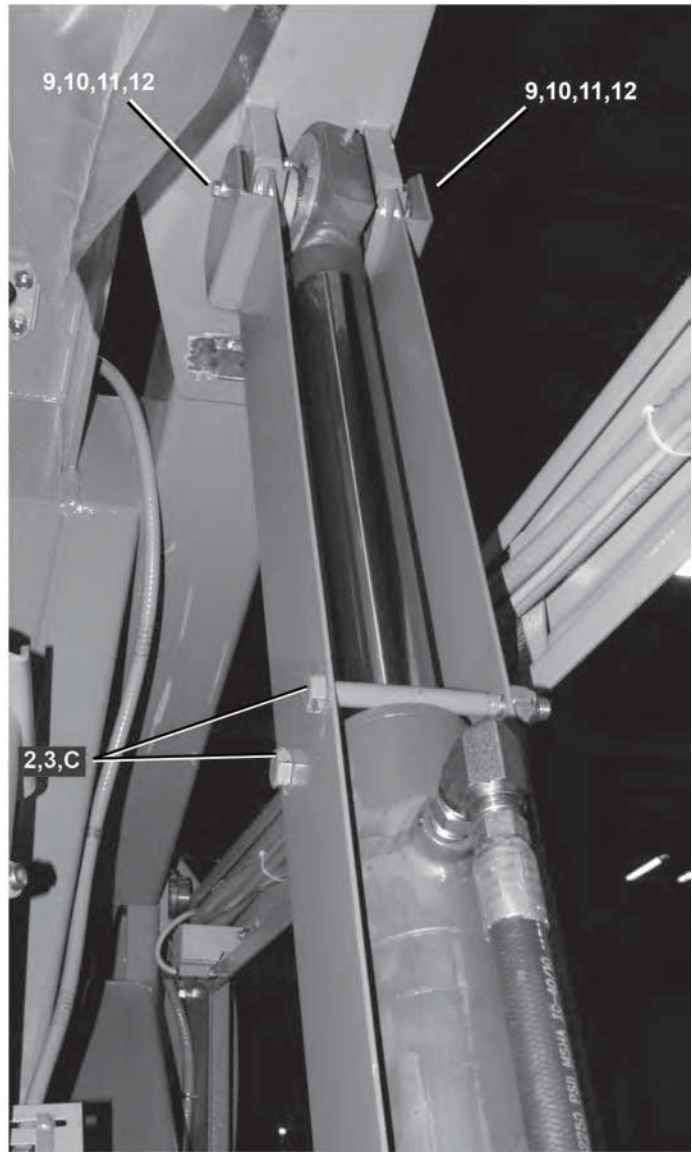
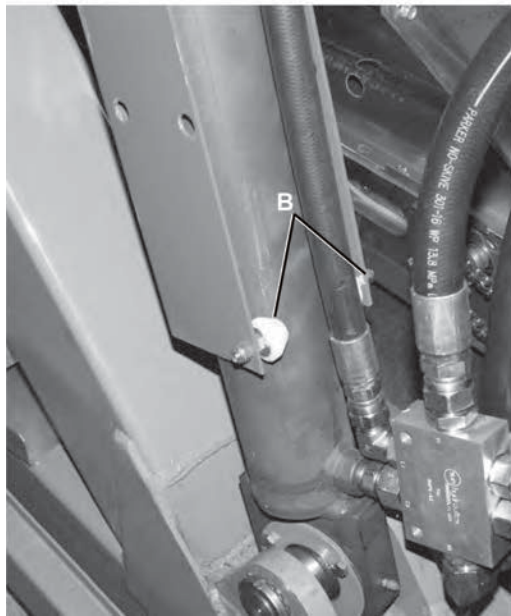
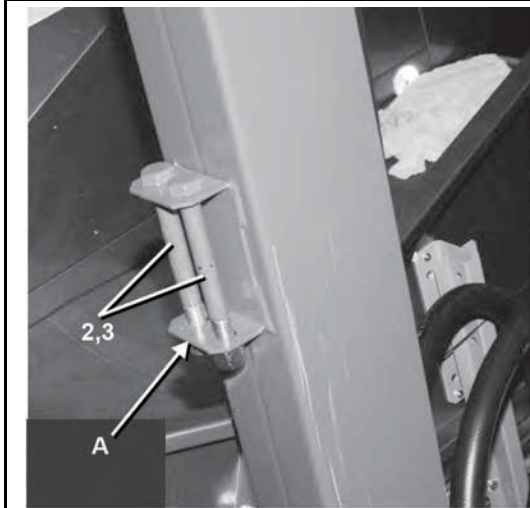


3. Remove electric power from the machine.

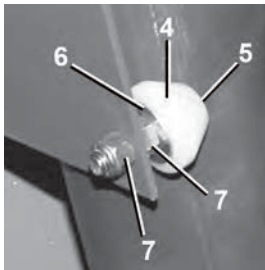
End of document: BNE48H01

Permanent Safety Stands

M7V4840C, M7V4836C



Guide Roller



Legend

- A . . . Bolt storage bracket
- B . . . Guide roller, 4 instances
- C . . . If bolts are lost, replace them with grade 8 bolts.

Permanent Safety Stands

M7V4840C, M7V4836C

Table 1. Parts List—Permanent Safety Stand

Find the assembly for your machine and the letter shown in the "Item" column. The components for your machine will show this letter or the word "all" in the "Used In" column. The numbers shown in the "Item" column are those shown in the illustrations.				
Used In	Item	Part Number	Description/Nomenclature	Comments
Reference Assemblies				
	A	GHT17010	ASSY=4840M HYDRAULICS	
Components				
all	1	W3 17160	4840 FULL-UP SHIPPING STAND	
all	2	15K227D	HEXCAPSCR 5/8-11X6 GR8 ZINC	
all	3	15G238N	HXLOCKNUT NYL 5/8-11UNC STL/	
all	4	X7 10004	PLATEN GUIDE BUTTON	
all	5	15K100	HEXCAPSCR 3/8-16X1+1/4 SS18-8	
all	6	15U245	FLTWASH 3/8 STD COMM 18-8 SS	
all	7	15G214	HXJAMNUT 3/8-16UNC2B SAE ZINC	
all	8	15U260	LOCKWASHER MEDIUM 3/8 SS18-8	
all	9	15K106E	BUTSOKCAPSCR 3/8-16NCX1+1/2 SS	
all	10	15U260	LOCKWASHER MEDIUM 3/8 SS18-8	
all	11	15U245	FLTWASH 3/8 STD COMM 18-8 SS	
all	12	27B2100G0L	SPCRROLL.39ID.562L.048T STLZNC	

Installation

1

HANDLING AND SETTING CENTRIFUGAL EXTRACTORS

Handling Precautions

1. Remove the protective coverings (leaving the machine on shipping skids) and examine carefully for possible shipping damage. **If the machine is damaged, notify the transportation company immediately.**
- NOTE:** Once the machine is given to the carrier, it is solely the responsibility of the carrier to ensure that no damage occurs during transit. In addition to readily apparent damage, carriers are liable for concealed damage. **Do not hesitate to file a claim with the carrier if the machine is damaged in any way during shipment.** Milnor® will be glad to assist you in filing your claim, but is not responsible for any shipping damage to the machine once it has been delivered to the carrier in good condition.
2. Consult Milnor® for instructions if crane lifting is required.
3. Use skids for fork lifting. If possible, leave the machine on shipping skids until it is near its final position. Once the skids are removed, take care in placing forks under the machine. **Do not allow the forks to come in contact with valves, piping, motors, etc., located under the machine.**
4. Never push, pull, lift, jack, or exert pressure on any components that protrude from the machine frame (shell front, door, electric boxes, controls, guards, conduits, conveyors, piping, etc.).

Site Requirements

Space Requirements

1. All openings and corridors through which equipment must pass during installation must be large enough to accommodate the width and the height of the machine as shown on the dimensional drawings. It is occasionally possible to reduce the overall dimensions by removing piping or other special modifications. Consult Milnor® for additional information.
2. Sufficient clearance must be provided for normal operation and maintenance procedures.

Operation Requirements

1. Allow sufficient ventilation for the heat and vapors of normal operation to dissipate.
2. Provide easy access to controls. Operators must be able to view all status lights and reach all controls associated with the machine.

Foundation Requirements—The floor and/or all other support components must have sufficient strength and rigidity with due consideration for the natural or resonant frequency thereof to withstand the fully loaded weight of the machine, including the wet goods and any repeated sinusoidal (rotating) forces generated during its operation. Determining the suitability of floors, foundations, and other supporting structures normally requires *analysis by a qualified structural engineer.*

Setting Procedures

To protect against lateral creeping of the machine during operation (due to vibration), roughen the area of the floor where the grout will be applied. Anchor bolts are required.

1. With the machine near the final location, unbolt the shipping skids. Observing all precautions, lift the machine off its skids, and lower the machine onto blockings. Shim the blockings until the machine is level and approximately 1" (25) clearance exists under each base pad. Install anchor bolts (as shown on the dimensional drawing), but **do not tighten bolts until grout is completely dry.**
2. Apply grout between the existing foundation floor and the base pads, observing the following considerations:
 - Use only industrial strength non-shrinking grout.
 - If the grout (after mixing) is too thin (causing it to flow from under the base pads), install temporary cardboard framing around pads to retain the grout until it cures.
 - If the grout (after mixing) is of proper consistency, pack or trowel by hand.

CAUTION

VIBRATION AND MALFUNCTION HAZARD—Voids under base pads can magnify vibration and cause unsatisfactory operation.

- ☞ **Grout must displace total clearance between base pads and existing foundation floor.**
 - ☞ **Voids must not exist.**
3. Tighten anchor bolts evenly using only one-quarter turn on each bolt before moving to the next one. While tightening, frequently skip from front to back and right to left to insure uniform tension. After tightening all bolts, check each bolt at least twice during the first week of operation.
 4. **Please check perforated cylinder for smoothness before placing machine in service. We cannot accept claims for damage to cylinder's smooth finish after machine has been placed in service.**

⚠ WARNING
Rigger is liable for damages both directly and indirectly caused by rigging.

3 point pick-up

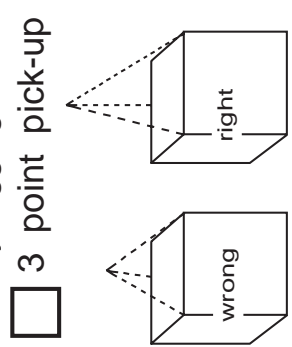
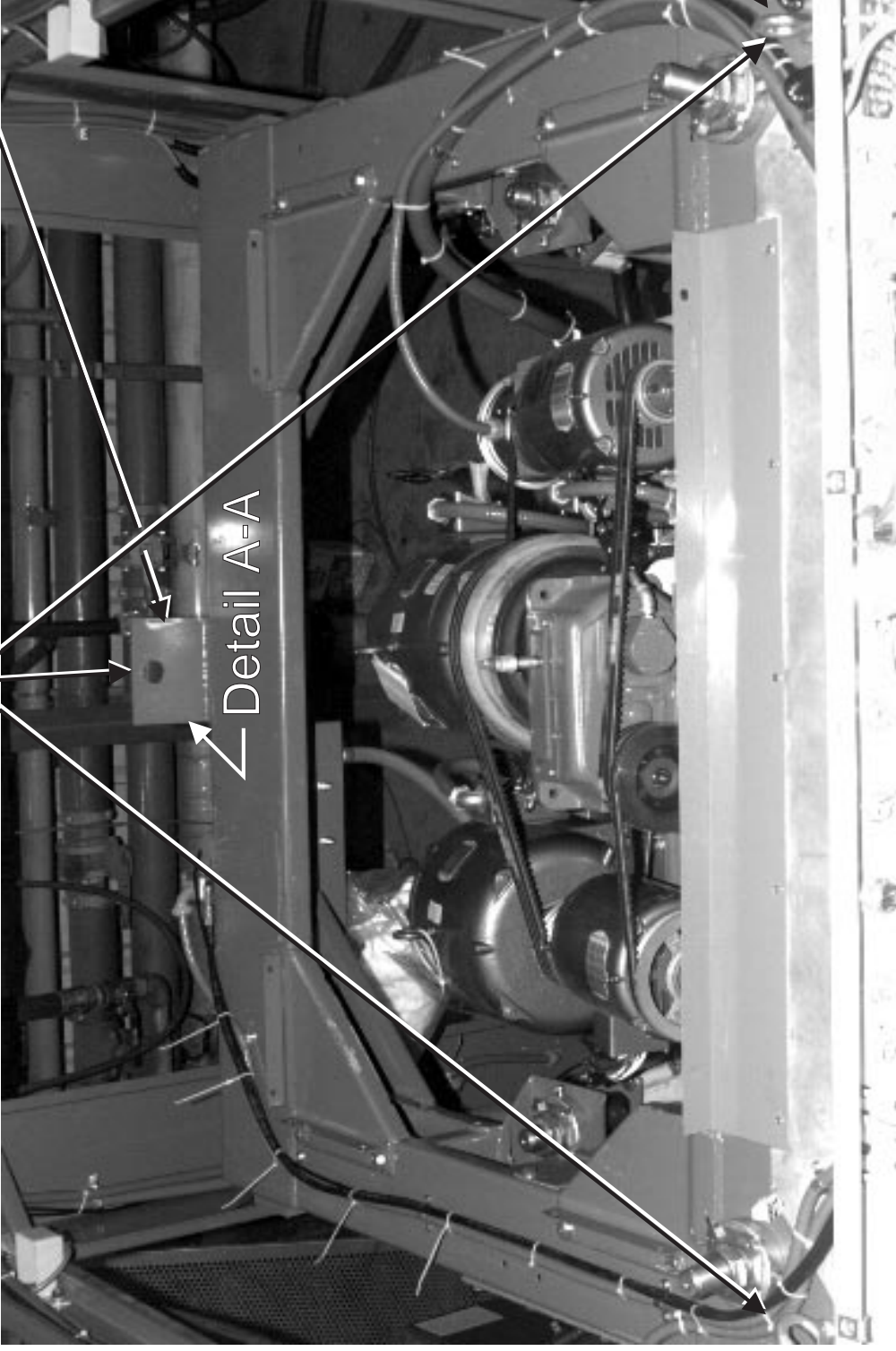
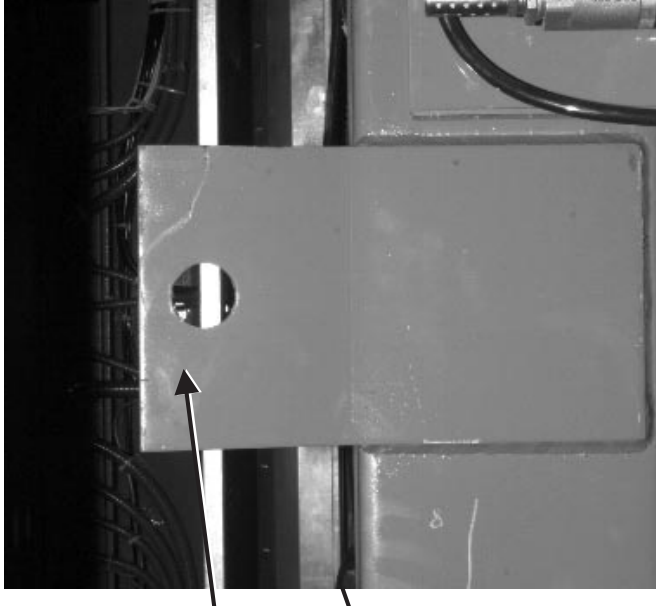


Diagram illustrating the correct 3-point pick-up method (right) and the incorrect method (wrong).

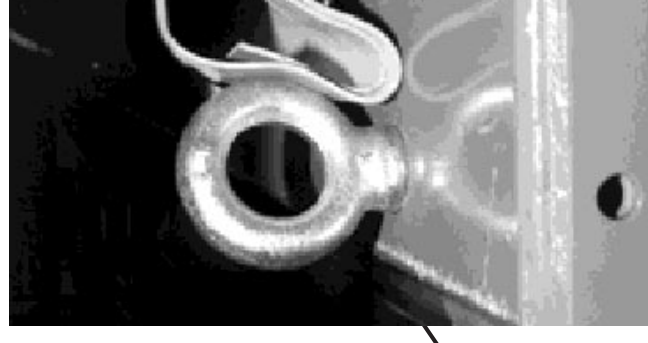
Lift here



Detail A-A

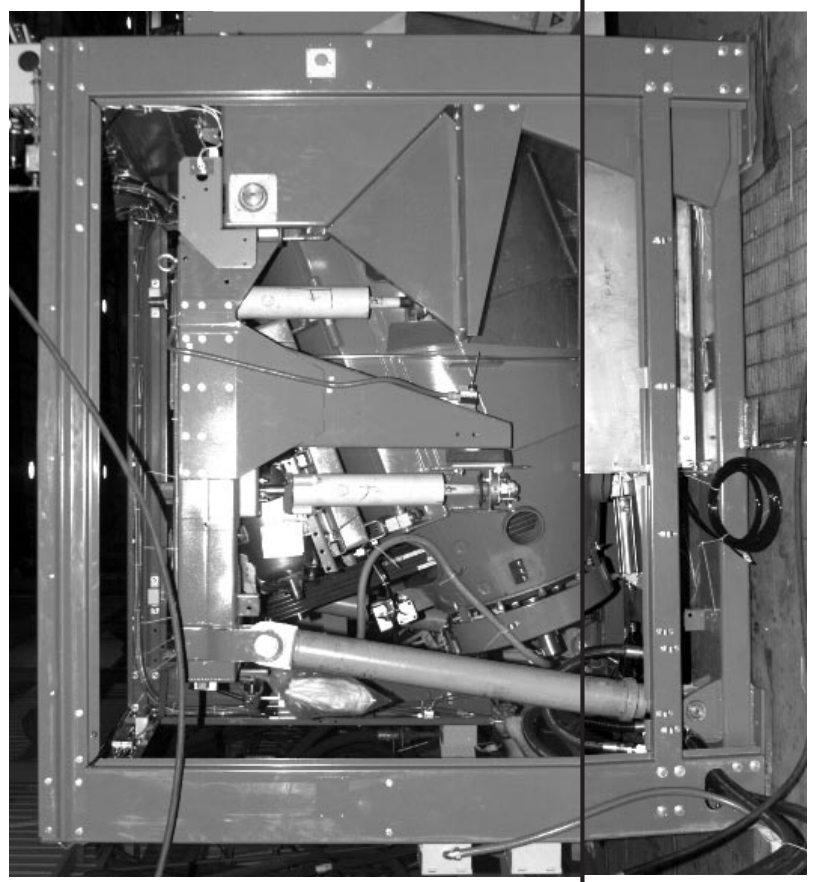
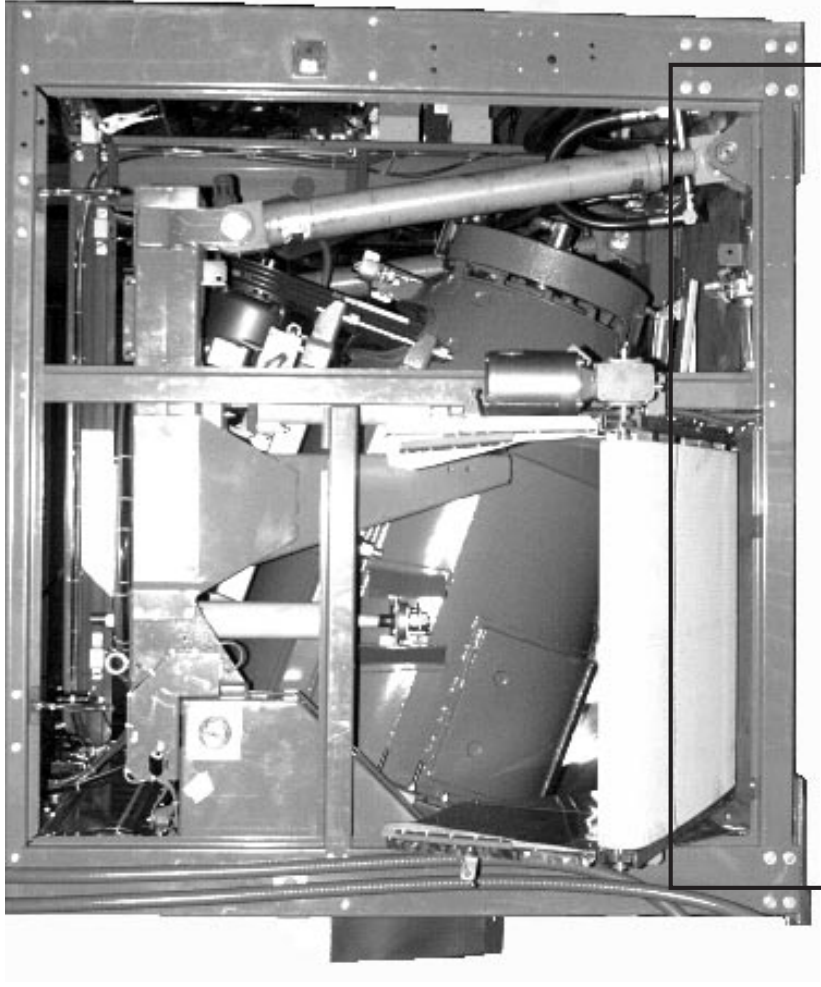


Rear lift point



Front lift point (at 2 places)

FIGURE 1 (MSINA406AE)
Lifting and Jacking Points



▲ CAUTION ▲
 Lift and jack at base only (shown below). Forklift blades must not contact conveyor, hydraulic lines, or cosmetics. See "Jacking Precautions" below.

base



Jacking Precautions
NOTE 1: Only lift or jack high enough to place or remove crawlers or other moving aids.
NOTE 2: When jacking machine, spread forks far enough apart to distribute weight properly. Do not rack machine!

FIGURE 2 (MSINA406AE)
 Lifting and Jacking Points

⚠ WARNING ⚠

Remove shipping restraints before attempting to run machine, but only after machine is in place. Restraints are usually marked with red, and may be concealed behind access panels. Replace those fasteners which are part of the machine structure.

Front shipping mounting bracket location (painted red)

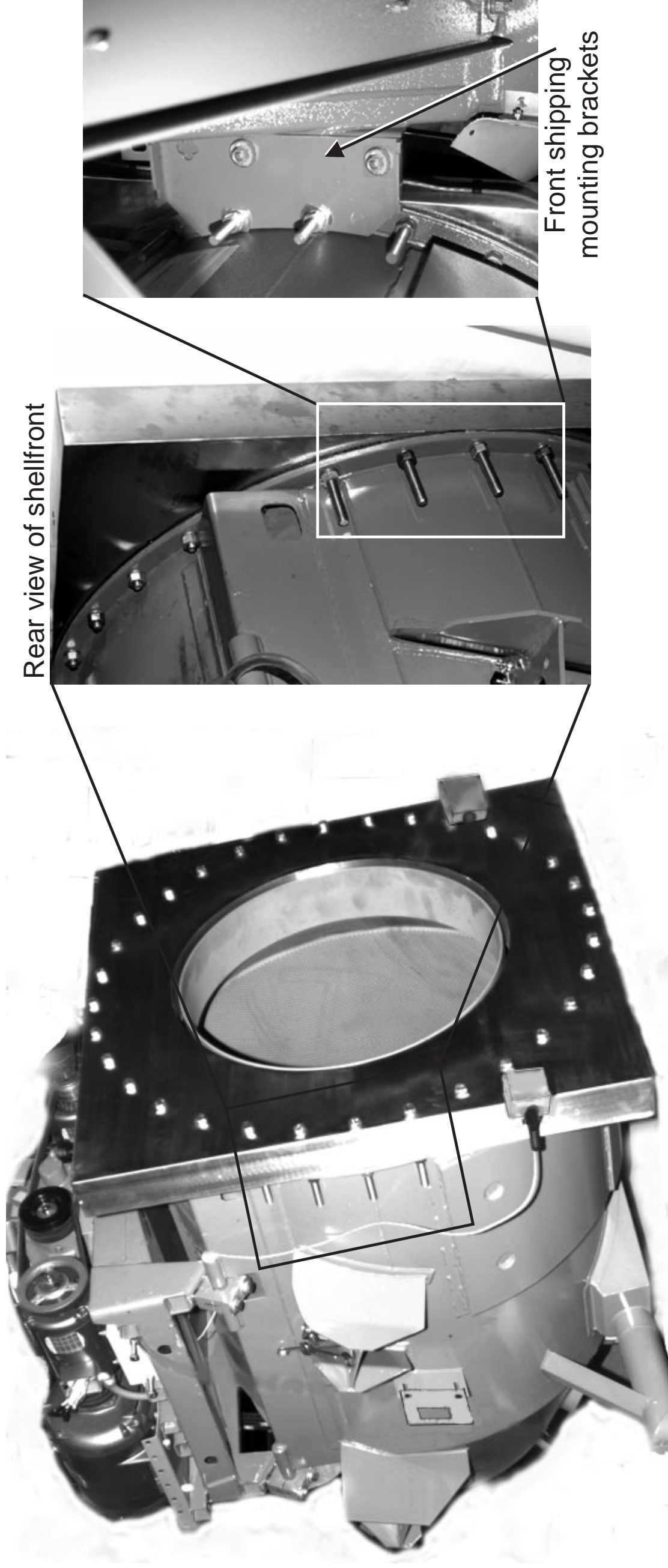


FIGURE 3 (MSINA406AE)
Shipping Brackets and Restraints (painted red)

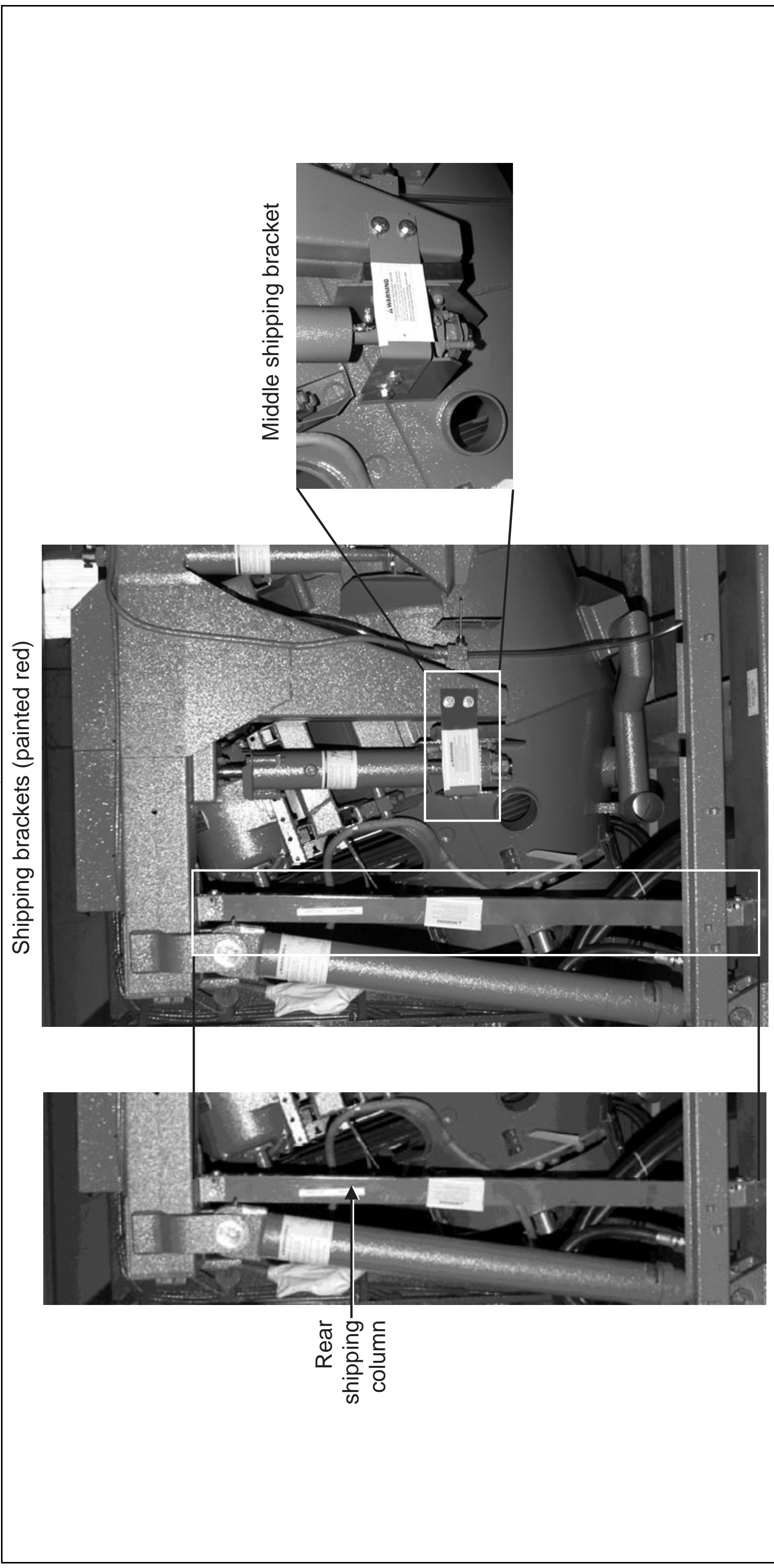


FIGURE 4 (MSINA406AE)
Shipping Restraints and Brackets (painted red)

CENTRIFUGAL EXTRACTOR SERVICE CONNECTIONS

General

These service connections are required (depending on the machine model and optional features):

1. Piped inlets and outlets (compressed air, reuse water, or drain and load chute drain, if equipped). The sizes and locations of piped inlets and outlets are shown on the dimensional drawings for the machine.
2. Electric power connections, (for additional information see “EXTERNAL FUSE AND WIRE SIZES FOR MILNOR[®] MACHINES” - MAEFUSE1AE).

Requirements for Piped Connections

Inlet pressures must be within the minimum/maximum range specified. Pressure outside of the specified range may cause the machine to operate inefficiently or malfunction, and may damage machine components.

▲ CAUTION ▲



MACHINE DAMAGE—Valve bodies will be ruined if twisted and distorted.
 ➔ Hold the connection side of the valve with a wrench when connecting plumbing.

Piped Inlet/Outlet Specifications—The piped inlet and outlet requirements are as follows (see dimensional drawings for the size and location of connection points):

Piped Inlets

Description of Connection	Source Requirements	Piping Specifications
Compressed air inlet	1" NPT 85-115 PSI (5.97-8.08 kilogram/centimeter ²)	Pipe material per plumbing code

Piped Outlets

Description of Connection	Destination Requirements	Piping Specifications
Reuse tank discharge pipe	1 1/2" NPT	Rubber hose, PVC, or other approved material per plumbing code
Drain (non-reuse equipped machines)	3" NPT unrestricted gravity feed to sewer	Same as above
Load chute drain (piped to sewer or reuse tank)	1" (25.4)	Flexible tubing or other approved material per plumbing code

When Making Electrical Power Connections

⚠ DANGER ⚠



ELECTROCUTION HAZARD—Contact with high voltages can kill or seriously injure you.

☞ All electrical connections must be made by a competent electrician.

1. Connections must be made by a competent electrician.
2. See fuse and wire sizing information in the schematic manual and on the machine nameplate.
3. “Stinger leg” if any, must be connected to terminal L3 only.
4. Make power connections within beltbox.
5. Only use BUSSMAN FUSETRON FRN (up to 250V), FRS (up to 600V) or similar lag fuses. The nameplate for fuse sizes must not be applied to standard fuses.
6. See nameplate for fuse and wire sizes. If wire runs more than 50 feet (15.24), increase by one wire size per each additional 50 feet (15.24).
7. Verify all motor rotation (see the M7E extractor reference manual for more information). If the cylinder turns in the wrong direction, interchange the wires connected to L1 and L2. **Never move L3, under any circumstances.**

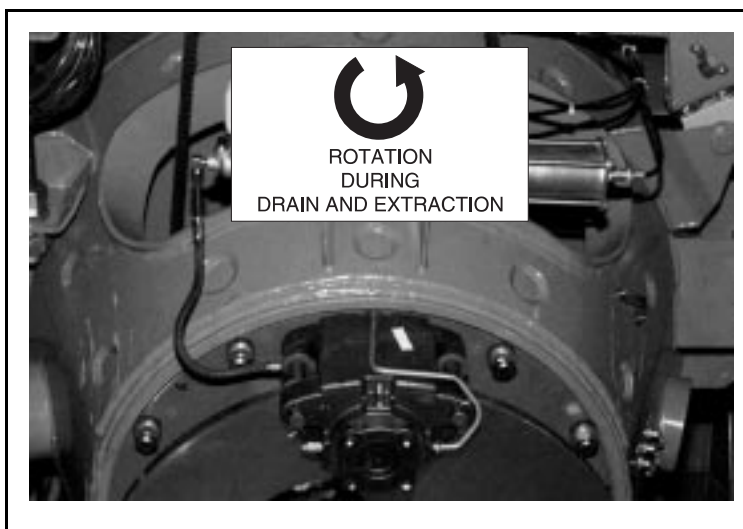


FIGURE 1 (MSIN0906AE)
Cylinder Rotation
(Viewed from rear)

NOTE: Before shipping, all motors are properly phased for correct rotation. It is possible to reverse the direction of rotation in a three-phase machine by interchanging the incoming power leads. Therefore, the rotation of a three-phase machine must be observed and corrected when the machine is first installed. If it is necessary to reverse the rotation, simply swap the incoming power lines to the machine (never move L3 if L3 is a stinger leg). Never attempt to reconnect motors or the motor control devices.

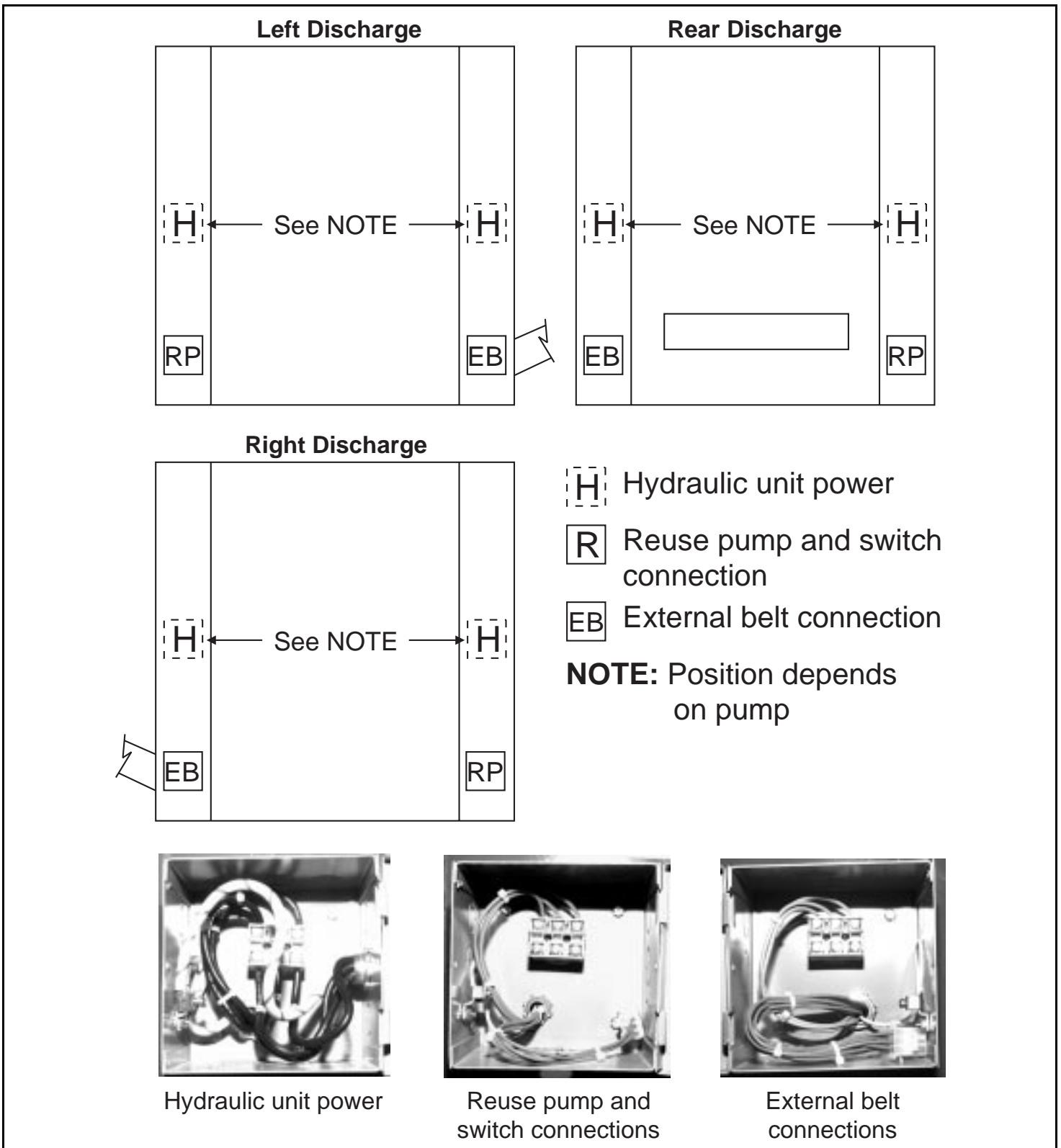
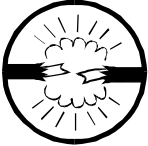


FIGURE 2 (MSIN0906AE)
Electrical Connections

Electric Power and Air Connections

⚠ CAUTION ⚠



Voltage fluctuations of more than 10% above or below the specified voltage for the machine are extremely detrimental to electrical components, especially motors.

✎ Correct any such condition prior to commissioning the machine.

The customer must furnish a remotely mounted disconnect switch with lag type fuses, circuit breakers, and wiring between the electrical service box and the junction box on the machine. The sizes of these fuses and wires, along with the motor fuses supplied with the machine, depend on the machine voltage. See fuse and wire sizing information in the schematic manual and on the machine nameplate.

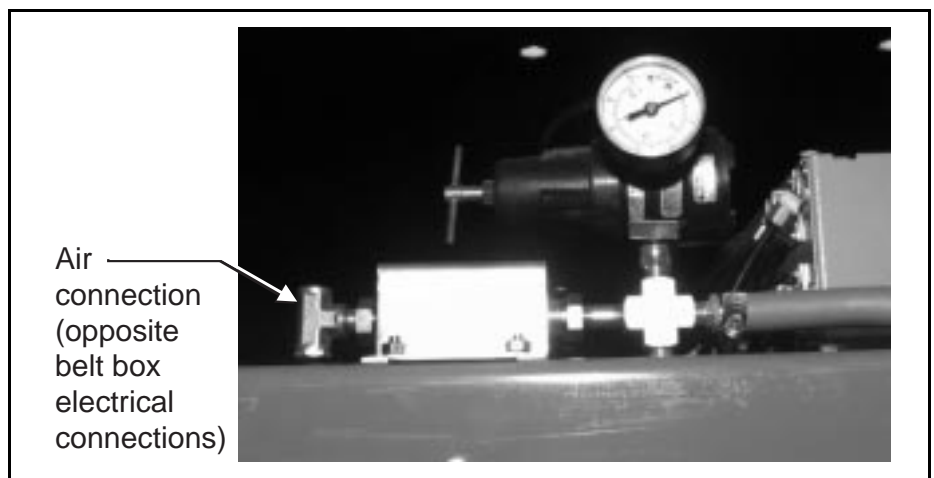


FIGURE 3 (MSIN0906AE)
Air Connection

AIR CONNECTION

MINIMUM 85 PSI (Generally)

MAXIMUM 110 PSI (Check nameplate on machine)

THE BRAKE INTERLOCK PRESSURE SWITCH WILL NOT PERMIT THE MACHINE TO EXTRACT IF THE AIR PRESSURE IS TOO LOW. THE MACHINE WILL ROTATE AT DRAIN SPEED INSTEAD.

If this happens, check your air compressor. If your gauge shows more than 85 PSI the gauge is probably faulty. Some air compressors are set with too great a pressure differential between the lowest pressure obtainable and the highest pressure obtainable. Hence, if your compressor is set to go on at 60 PSI and off at 110 PSI, the machine will extract quite satisfactorily whenever the air pressure is above 85 PSI, but will not enter extraction at all when the pressure is below 85 PSI.

⚠ CAUTION

USE ONLY YOUR FINGERS TO DEPRESS THE KEYS.

NEVER USE SHARP OBJECTS.

WHEN USED PROPERLY THIS KEYPAD WILL WITHSTAND HEAVY INDUSTRIAL USE.

DAMAGE MAY OCCUR IF KEYS ARE DEPRESSED BY A SCREWDRIVER, PEN, ETC.

FIGURE 4 (MSIN0906AE)
Air and Electrical Connection Precautions

About the Forces Transmitted by Milnor® Washer-extractors

During washing and extracting, all washer-extractors transmit both static and dynamic (cyclic) forces to the floor, foundation, or any other supporting structure. During washing, the impact of the goods as they drop imparts forces which are quite difficult to quantify. Size for size, both rigid and flexibly-mounted machines transmit approximately the same forces during washing. During extracting, rigid machines transmit forces up to 30 times greater than equivalent flexibly-mounted models. The actual magnitude of these forces vary according to several factors:

- machine size,
- final extraction speed,
- amount, condition, and type of goods being processed,
- the liquor level and chemical conditions in the bath preceding extraction, and
- other miscellaneous factors.

Estimates of the maximum force normally encountered are available for each Milnor® model and size upon request. Floor or foundation sizes shown on any Milnor® document are only for on-grade situations based only on previous experience without implying any warranty, obligation, or responsibility on our part.

1. Rigid Machines

Size for size, rigid washer-extractors naturally require a stronger, more rigid floor, foundation, or other supporting structure than flexibly-mounted models. If the supporting soil under the slab is itself strong and rigid enough and has not subsided to leave the floor slab suspended without support, on grade installations can often be made directly to an existing floor slab if it has enough strength and rigidity to safely withstand our published forces without transmitting undue vibration. If the subsoil has subsided, or if the floor slab itself has insufficient strength and rigidity, a deeper foundation, poured as to become monolithic with the floor slab, may be required. Support pilings may even be required if the subsoil itself is “springy” (i.e., if its resonant frequency is near the operating speed of the machine). Above-grade installations of rigid machines also require a sufficiently strong and rigid floor or other supporting structure as described below.

2. Flexibly-mounted Machines

Size for size, flexibly-mounted machines generally do not require as strong a floor, foundation, or other supporting structure as do rigid machines. However, a floor or other supporting structure having sufficient strength and rigidity, as described in [Section 3](#), is nonetheless vitally important for these models as well.

3. How Strong and Rigid?

Many building codes in the U.S.A. specify that laundry floors must have a minimum live load capacity of 150 pounds per square foot (732 kilograms per square meter). However, even compliance with this or any other standard does not necessarily guarantee sufficient rigidity. In any event, it is the sole responsibility of the owner/user to assure that the floor and/or any other supporting structure exceeds not only all applicable building codes, but also that the floor and/or any other supporting structure for each washer-extractor or group of washer-extractors actually has sufficient strength and rigidity, plus a reasonable factor of safety for both, to support the weight of all the fully loaded machine(s) including the weight of the water and goods, and including the published 360° rotating sinusoidal RMS forces that are transmitted by the machine(s). Moreover, the floor, foundation, or other supporting structure must have sufficient

rigidity (i.e., a natural or resonant frequency many times greater than the machine speed with a reasonable factor of safety); otherwise, the mentioned 360° rotating sinusoidal RMS forces can be multiplied and magnified many times. It is especially important to consider all potential vibration problems that might occur due to all possible combinations of forcing frequencies (rotating speeds) of the machine(s) compared to the natural frequencies of the floor and/or any other supporting structure(s). A qualified soil and/or structural engineer must be engaged for this purpose.

Figure 1: How Rotating Forces Act on the Foundation

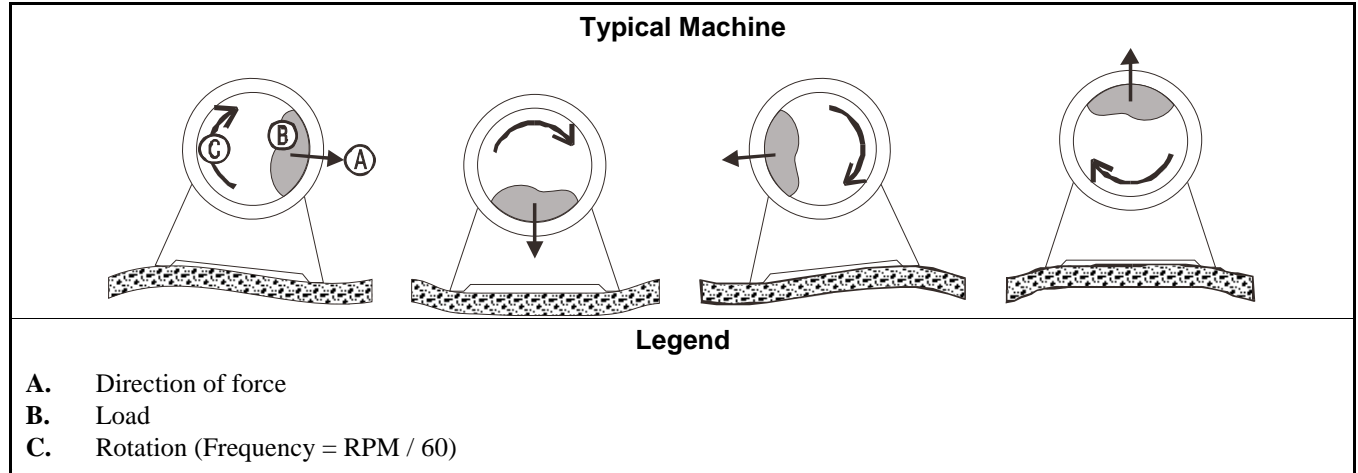


Figure 1 above is intended to depict both on-grade and above-grade installations and is equally applicable to flexibly-mounted washer-extractors, as well as to rigid models installed either directly on a floor slab or on a foundation poured integrally with the slab. Current machine data is available from Milnor® upon request. All data is subject to change without notice and may have changed since last printed. It is the sole responsibility of every potential owner to obtain written confirmation that any data furnished by Milnor® applies for the model(s) and serial number(s) of the specific machines.

— End of BIWUI02 —

BIUUUI02PE (Published) Book specs- Dates: 20160712 / 20160712 / 20160712 Lang: ENG01 Applic: PEU

Tag Guidelines for the Models Listed Below

M7V4232C	M7V4232L	M7V4232R	M7V4836C	M7V4836L	M7V4836R	M7V4840C
M9S4232C	M9S4232L	M9S4232R	M9V4232C	M9V4232L	M9V4232R	M9V4840C
M9V4840L	M9V4840R	MMS4232C	MMS4232L	MMS4232R	MMV4232C	MMV4232L
MMV4232R	MXS4232C	MXS4232L	MXS4232R	MXV4232C	MXV4232L	MXV4232R

Notice 1: This information may apply to models in addition to those listed above. It applies to paper tags. It does not apply to the vinyl or metal safety placards, which must remain permanently affixed to the machine and replaced if no longer readable.

Paper tags on the machine provide installation guidelines and precautions. The tags can be tie-on or adhesive. You can remove tie-on tags and white, adhesive tags after installation. Yellow adhesive tags must remain on the machine.

Tag Guidelines for the Models Listed Below

The following entries explain the installation tags. Each entry includes: 1) the tag illustration, 2) the tag part number displayed at the bottom of the tag, and 3) the meaning of the tag.

Display or Action



Explanation

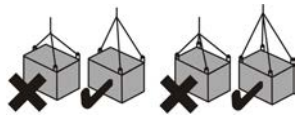
Read the manuals before proceeding. This symbol appears on most tags. The machine ships with safety, operator, and routine maintenance guides for customer use. Milnor dealer manuals for installing, servicing, and commissioning this machine are also available from the Milnor Parts department.



B2TAG88005: This carefully built product was tested and inspected to meet Milnor® performance and quality standards by (identification mark of tester).



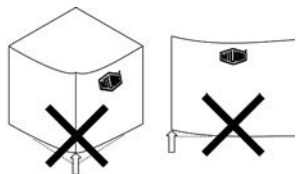
B2TAG94078: Do not forklift here; do not jack here; do not step here—whichever applies.



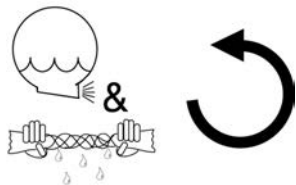
B2TAG94079: Rig for crane lifting (either 3-point or 4-point, depending on the number of lifting eyes provided) using a steep angle on the chains (closer to vertical than horizontal).



B2TAG94081: Motor must rotate in this direction. On single motor washer-extractors and centrifugal extractors, the drive motor must turn in this direction during draining and extraction. This tag is usually wrapped around a motor housing. If the motor turns in the opposite direction when the machine is first tested, the electrical hookup is incorrect and must be reversed as explained in the schematic manual.

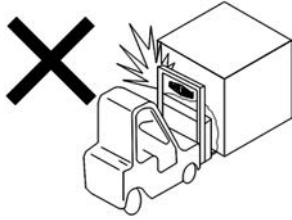


B2TAG94084: Do not lift from one corner of the machine, as this can cause the frame to rack, damaging it.



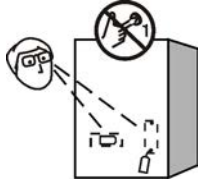
B2TAG94097: The cylinder must rotate **counterclockwise** during draining and extraction (spin) when viewed from here (rear of machine). Otherwise, reverse the electric power connections, as explained in the schematic manual.

Display or Action



Explanation

B2TAG94118: Do not strike shipping container during fork-lifting. Fragile components inside.



B2T2001028: Look for tags inside the machine. These tags may identify shipping restraints to be removed or components to be installed. Do not start the machine until these actions are completed.



B2T2002013: Do not start the machine until shipping restraints are removed. This tag will appear on the outside of the machine to alert you to the presence of internal shipping restraints. A tag will also appear on the restraint to help identify it. Most, but not all shipping restraints display the color red. Some shipping restraints are also safety stands. Do not discard these.

— End of BIUUUI02 —

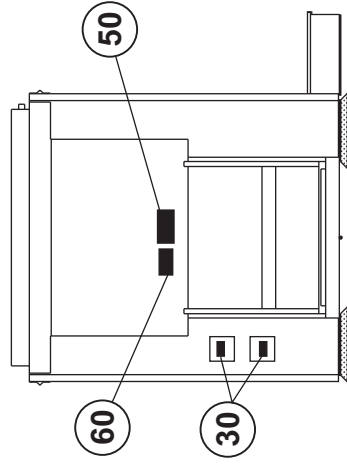


Pellerin Milnor Corporation
P. O. Box 400, Kenner, LA 70063-0400

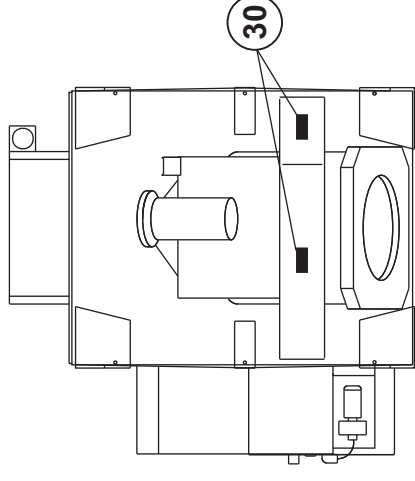
Litho in U.S.A.

Notes:

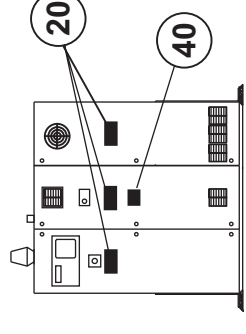
1. Replace placard immediately, if removed or unreadable.
2. Approximate locations of placards are shown. Mounting holes are provided on machine. If aluminum placard use #8 self-tapping screws.



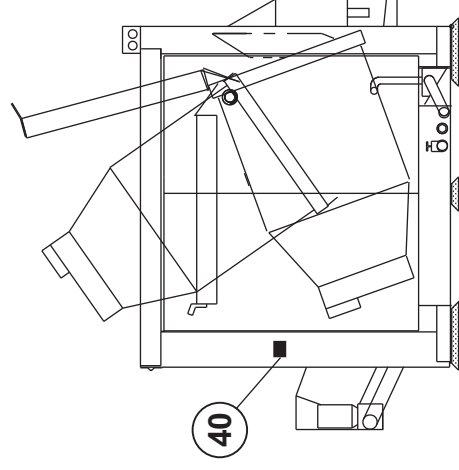
REAR VIEW



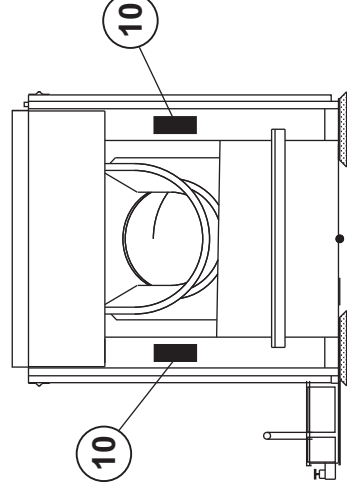
PLAN VIEW



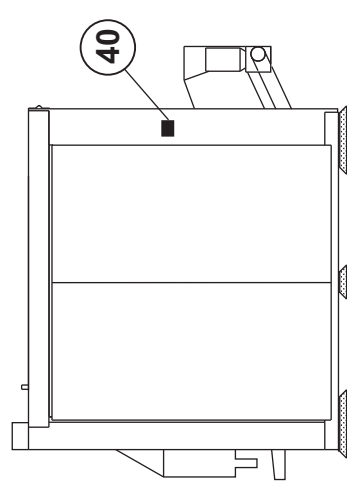
CONTROLS
FRONT VIEW



LEFT VIEW



FRONT (LOAD END) VIEW



RIGHT VIEW



Pellerin Milnor Corporation
P. O. Box 400, Kenner, LA 70063-0400

Litho in U.S.A.

Parts List—Safety Placard Placement

Find the correct assembly first, then find the needed components. The item letters (A, B, C, etc.) assigned to assemblies are referred to in the "Used In" column to identify which components belong to an assembly. The item numbers (1, 2, 3, etc.) assigned to components relate the parts list to the illustration.

Used In	Item	Part Number	Description	Comments
			-----ASSEMBLIES-----	
			none	
			-----COMPONENTS-----	
all	10	01 10583A	NPLT:64/72 W/E WARN FRT-TCATA	
all	20	01 10377A	NPLT:ELEC HAZARD LG-TCATA	
all	30	01 10375B	NPLT:ELEC HAZARD SMALL-TCATA	
all	40	01 10699B	NPLT:SERV HZRD-ALUM-TCATA	
all	50	01 10634A	NPLT:CONVEYOR HAZARDS-TCATA	
all	60	01 10630A	NPLT:TILT CRUSH HAZARD-TCATA	



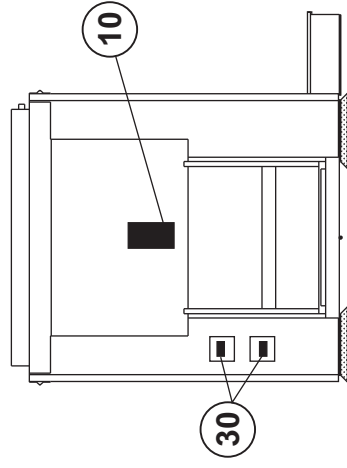
Pellerin Milnor Corporation
P. O. Box 400, Kenner, LA 70063-0400

Litho in U.S.A.

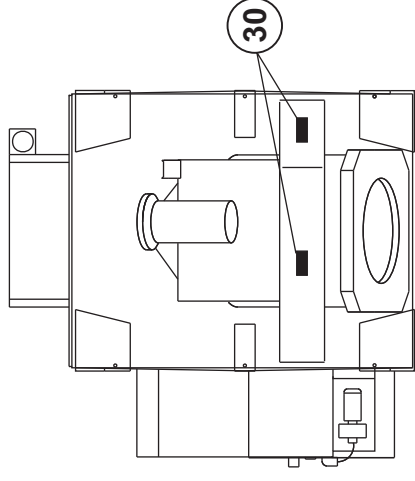
ISO Placards shown on this page

Notes:

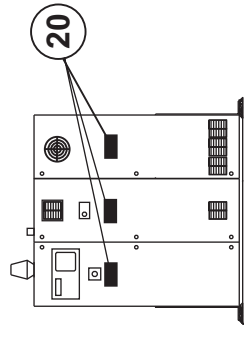
1. Replace placard immediately, if removed or unreadable.
2. Approximate locations of placards are shown. Mounting holes are provided on machine. If aluminum placard use #8 self-tapping screws.



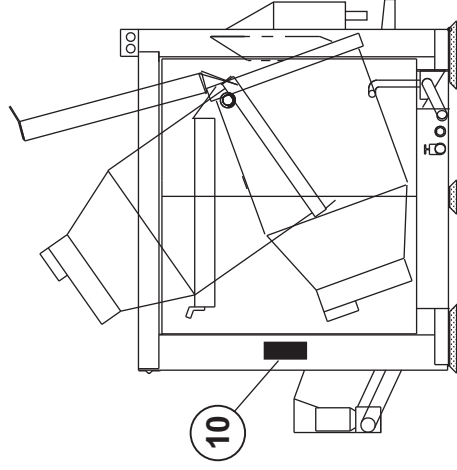
REAR VIEW



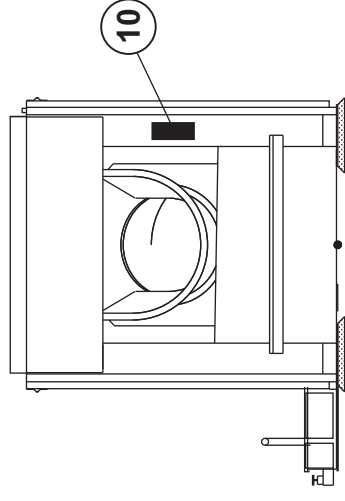
PLAN VIEW



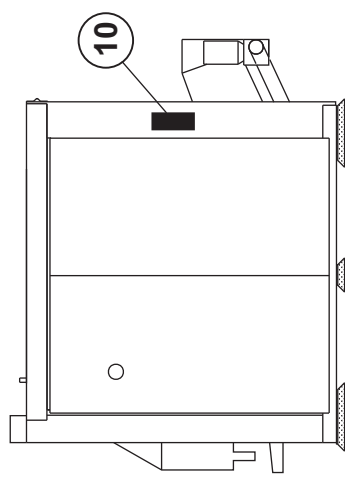
CONTROLS
FRONT VIEW



LEFT VIEW



FRONT (LOAD END) VIEW



RIGHT VIEW



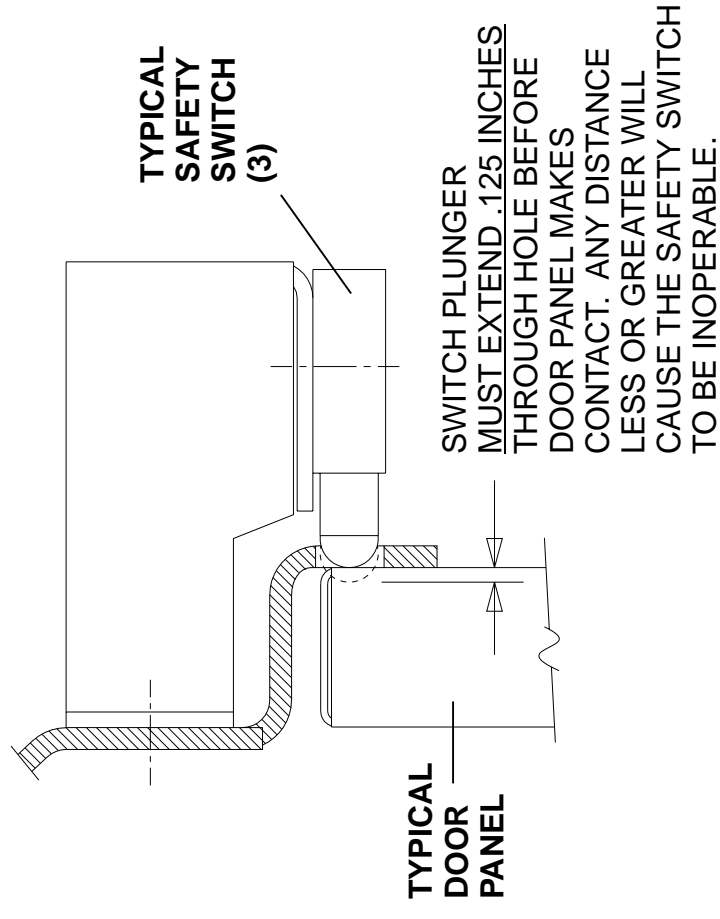
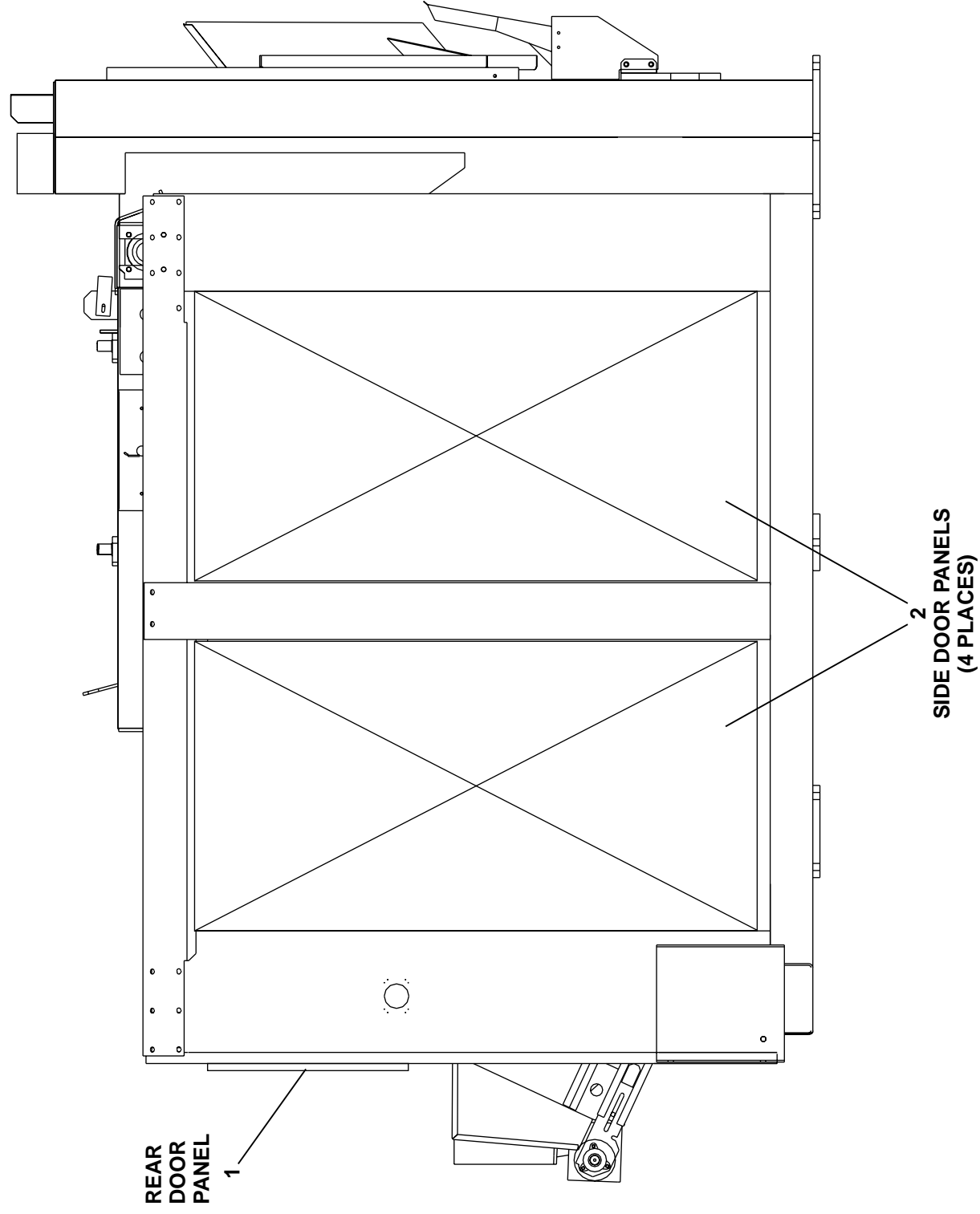
Pellerin Milnor Corporation
 P. O. Box 400, Kenner, LA 70063-0400

Litho in U.S.A.

Parts List—Safety Placard Placement

Find the correct assembly first, then find the needed components. The item letters (A, B, C, etc.) assigned to assemblies are referred to in the "Used In" column to identify which components belong to an assembly. The item numbers (1, 2, 3, etc.) assigned to components relate the parts list to the illustration.

Used In	Item	Part Number	Description	Comments
-----ASSEMBLIES-----				
none				
-----COMPONENTS-----				
all	10	01 10588X	NPLT:M7E EXTRACTOR WARNG ISO	
all	20	01 10377	NPLTE:"WARNING" 4X4	
all	30	01 10375	NPLTE:"WARNING" 2X2	



SWITCH IS ENGAGED WHEN THE DOOR PANEL DEPRESSES THE ROLLER PLUNGER THROUGH THE ACCESS HOLE.

DOOR SAFETY SWITCH INSTALLATION



Pellerin Milnor Corporation
P. O. Box 400, Kenner, LA 70063-0400

Litho in U.S.A.

Parts List—Guards & Covers

Find the correct assembly first, then find the needed components. The item letters (A, B, C, etc.) assigned to assemblies are referred to in the "Used In" column to identify which components belong to an assembly. The item numbers (1, 2, 3, etc.) assigned to components relate the parts list to the illustration.

Used In	Item	Part Number	Description	Comments
			-----ASSEMBLIES-----	
	A	GG517000	4840M COSMETIC INSTALL	
			-----COMPONENTS-----	
all	1	03 17180	4840M COSM REAR PANEL	
all	2	AGS16000	ASSY=COSM COVER 79.19X40.81	
all	3	09RM01418G	CAPSW 18'ROTARY ACTUATE GOLD	

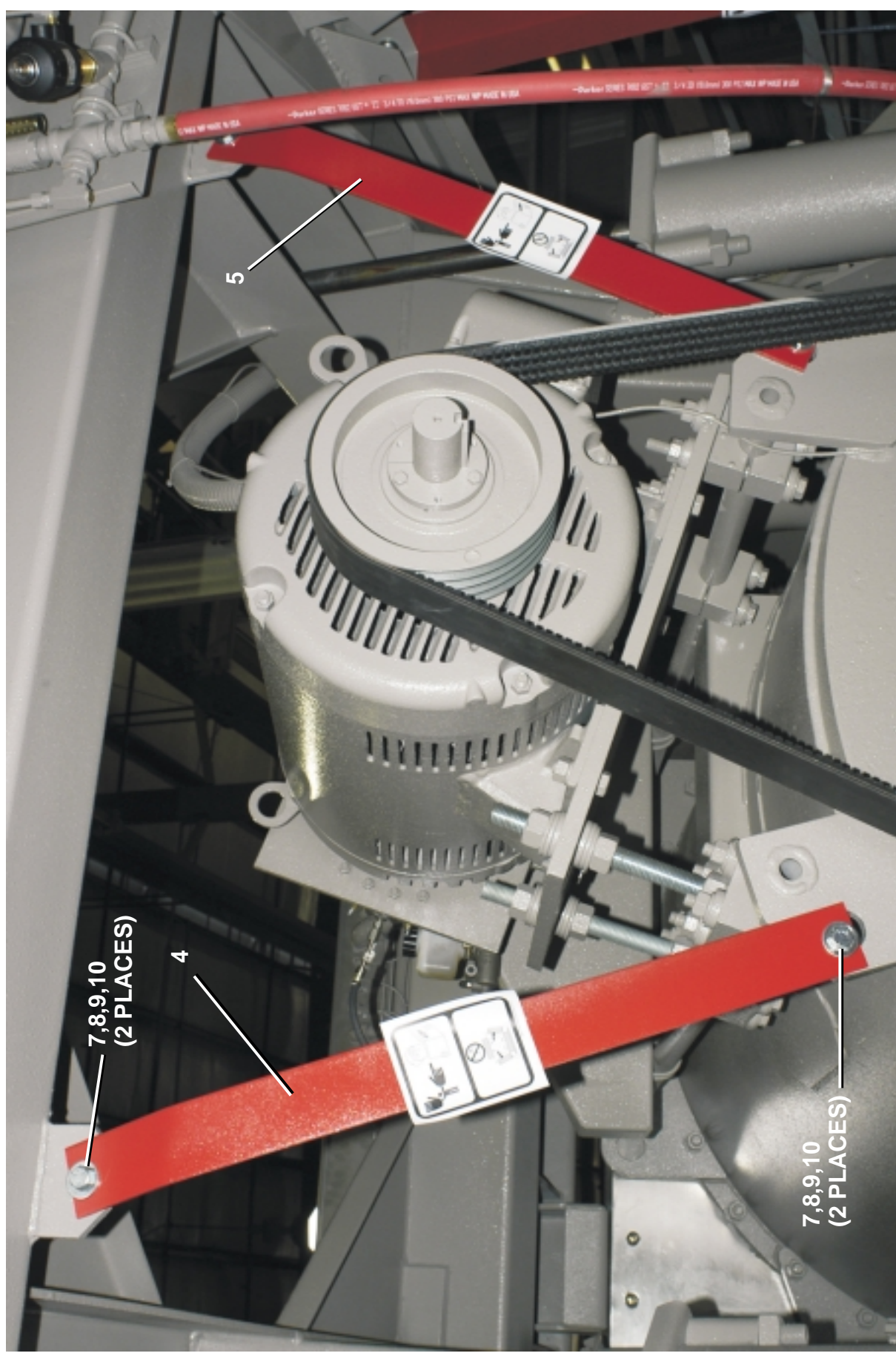
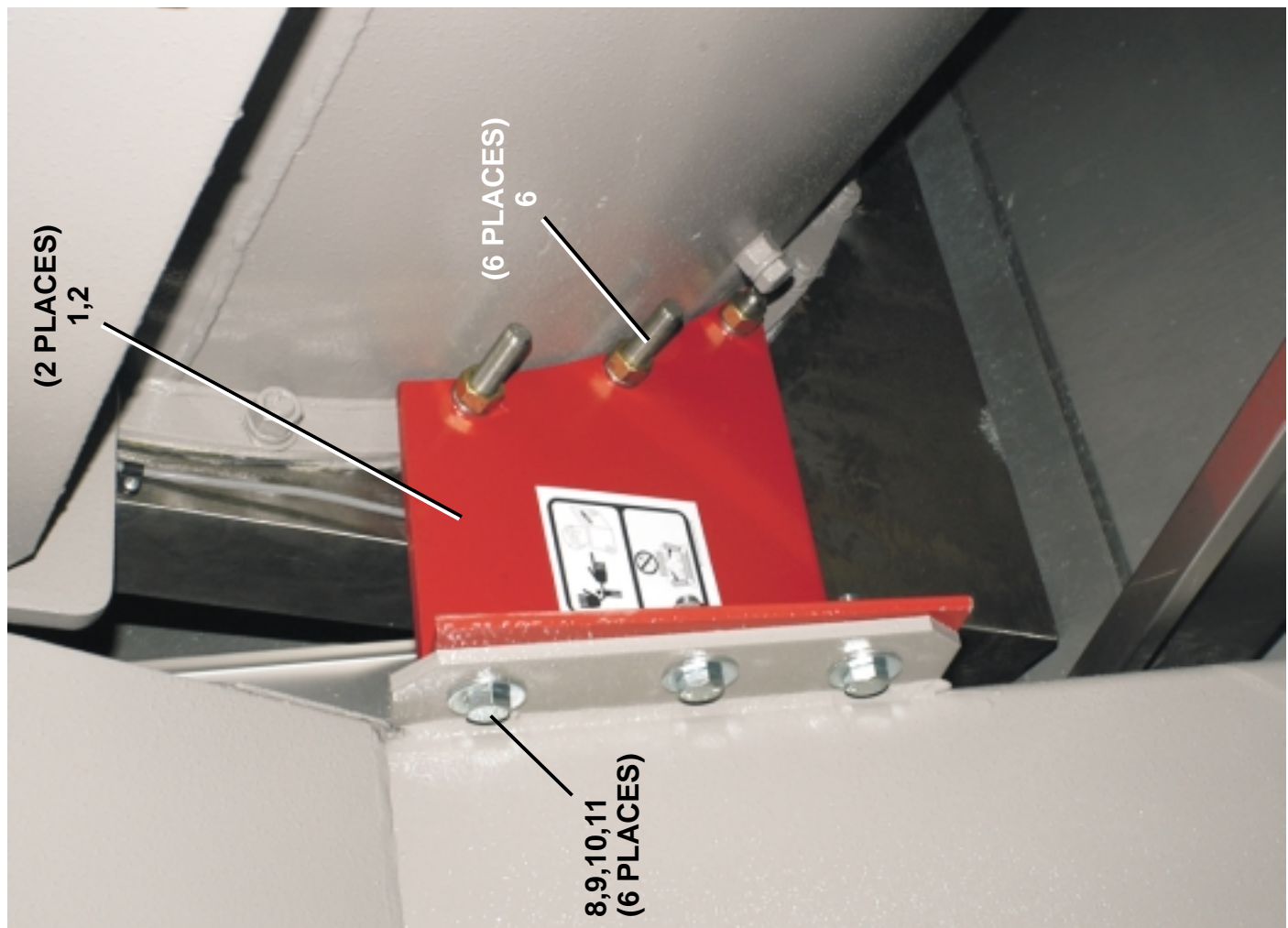
Shipping Brackets
M7V4840C, M7V4836C

BMP050045/2005255V
(Sheet 1 of 2)



Pellerin Milnor Corporation
P. O. Box 400, Kenner, LA 70063-0400

Litho in U.S.A.



Shipping Brackets

M7V4840C, M7V4836C

BMP050045/2005255V
(Sheet 2 of 2)

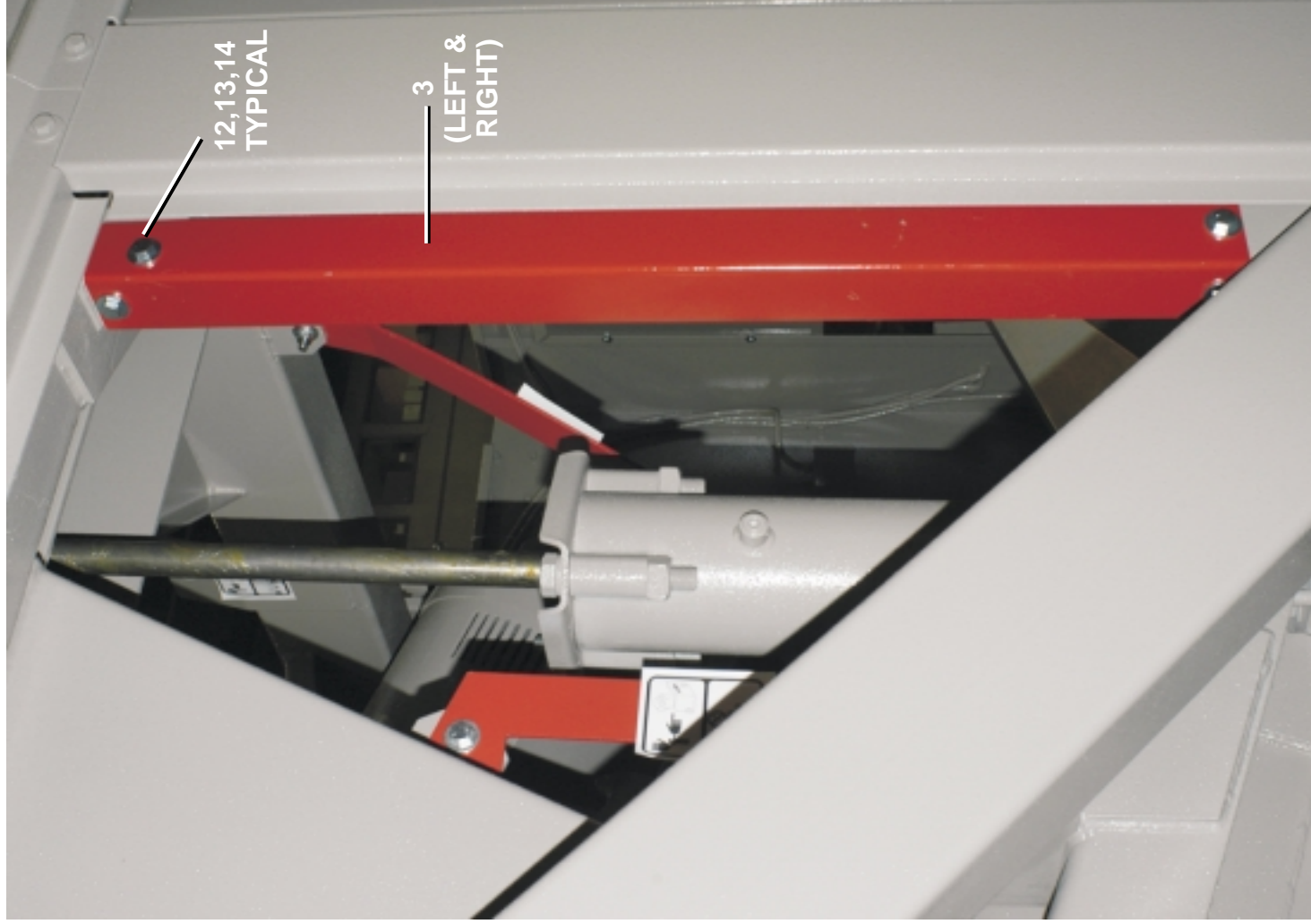


Pellerin Milnor Corporation
P. O. Box 400, Kenner, LA 70063-0400

Litho in U.S.A.

Parts List—Shipping Brackets
Find the correct assembly first, then find the needed components. The item letters (A, B, C, etc.) assigned to assemblies are referred to in the "Used In" column to identify which components belong to an assembly. The item numbers (1, 2, 3, etc.) assigned to components relate the parts list to the illustration.

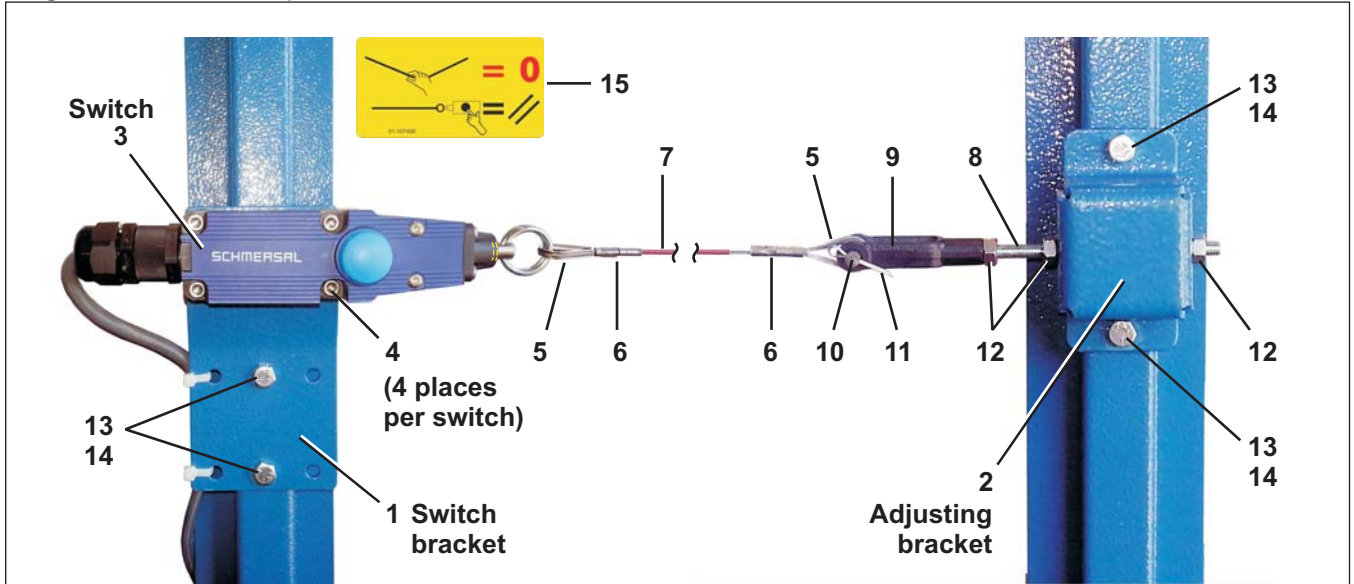
Used In	Item	Part Number	Description	Comments
	A	GHS17001	-----ASSEMBLIES----- INST=HOUSE SHIPPING 48M7	
			-----COMPONENTS-----	
all	1	03 17153	4840M FRNT SHIP BRKT BOLT-RT	
all	2	03 17153A	4840M FRNT SHIP BRKT BOLT-LF	
all	3	03 17152C	BRKT=SHIP REAR VERTICAL	
all	4	03 17155	4840-SHIP BRACKET REAR-RT	
all	5	03 17155A	4840-SHIP BRACKET REAR-LF	
all	6	W3 17003	BOLT=SHIP BRKT 4840M	
all	7	15K235A	HXCPCSC 3/4-10X2.5 GR 8	
all	8	15U320P	FLATWASHER(USS STD) 3/4" ZNC P	
all	9	15U340	LOCKWASH MEDIUM 3/4 ZINCPL	
all	10	15G240	HXNUT 3/4-10UNC2B SAE ZINC GR2	
all	11	15K232A	HXCPCSC 3/4-10X2 GR8 ZC	
all	12	15U494	3/4SAE CLPFW.812IDX1.5ODX.135T	
all	13	15U350	LOCKWASHER 3/4 MED SS18-8	
all	14	15G244A	HEXNUT 3/4-10UNC2B BRASS	



Pull-wire Stop Switch

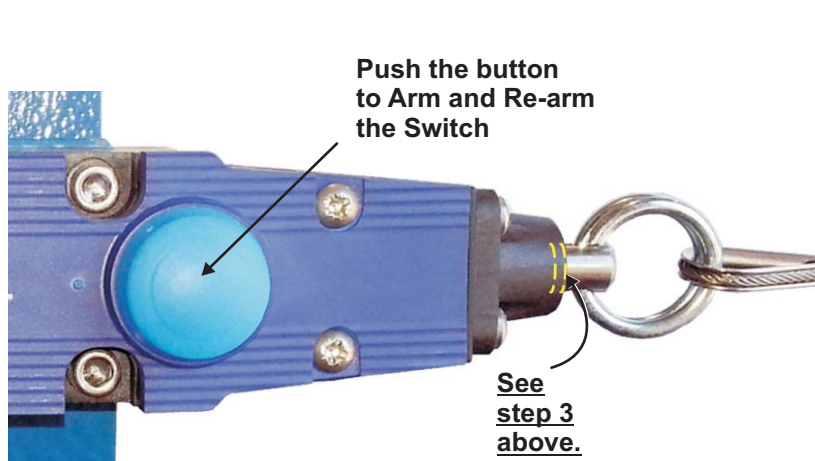
All Conveyors

Figure 1: Pull-wire Stop Switch Installation



Installation and operation:

1. Install the switch bracket, switch, and adjusting bracket to the conveyor side supports as shown. (Install pull-wire stop switch to both sides of all conveyors.)
For long spans, intermediate wire supports are required every 2 m to 5 m (6 ft to 16 ft). Sufficient space must be provided so that maximum perpendicular force on the wire to activate the switch is 200 N (45 pounds) and the maximum deflection of the wire is 400 mm (15").
2. Assemble and install the cable (pull cord), thimbles, and sleeves so that the cable is tight but does not begin to move the switch shaft.
3. Adjust the position of the threaded rod (item 8) so that the cable pulls the switch shaft out until the first of two notches on the shaft is visible but the second notch is not.
4. Tighten the nuts on the threaded rod (item 12) to hold it at this position.



5. Press the button on the switch to ARM. The button should remain depressed. If it does not, the switch shaft is not in the correct position.
6. Press the button to RE-ARM the switch after the wire has been tripped.

Pull-wire Stop Switch

All Conveyors

<p align="center">Parts List—Pull-wire Stop Switch</p> <p>Find the correct assembly first, then find the needed components. The item letters (A, B, C, etc.) assigned to assemblies are referred to in the "Used In" column to identify which components belong to an assembly. The item numbers (1, 2, 3, etc.) assigned to components relate the parts list to the illustration.</p>				
Used In	Item	Part Number	Description	Comments
			-----ASSEMBLIES-----	
	A	ALC40005E	PULL-WIRE STOP SWITCH ASSY	
			-----COMPONENTS-----	
	1	04 20066	WIREPULL SWITCH BRACKET	CONVEYORS PLUS CONWA/CONLO
	1	04 24128	SAFETY SW MTG PLATE-4232M	EXTRACTOR CONVEYORS
all	2	04 20067	WIREPULL ADJUSTING BRKT	
all	3	09RS0002	PULL-WIRE SW SCHMERSAL#ZQ 700-11	
all	4	15K022B	SOKCPSCR 10-24UNC X 1+1/2"LG SS18	
all	5	27A951	1/16" SS WIRE ROPE THIMBLE	
all	6	27A952	1/16" OVAL SLEEVE S/S	
all	7	27A953	CABLE-AIRCRAFT 1/16SS7X7REDCV	
all	8	17R015	THRD ROD 1/4-28UNFX4.5" ZNC PL	
all	9	17A004	ADJ YOKE END 1/4-28 XYLAN COAT	
all	10	17A004A	CLEVIS PIN 1/4"X3/4"DRILLED SS	
all	11	15H031	STDCOTTERPIN 3/32X3/4 SS18-8	
all	12	15G177	HXNUT 1/4-28UNF2B SAE ZINC GR2	
all	13	15K038B	1/4-20X 1/2 HEXFLANGE SCREW	
all	14	15G178	1/4"-20 HEXFLANGE NUT ZINC	
all	15	01 10749X	NPLT:PULL TO STOP+RESET>ISO	

Service and Maintenance

2

BIPV7M01 (Published) Book specs- Dates: 20040324 / 20040324 / 20040324 Lang: ENG01 Applic: PV7

Centrifugal Extractor Preventive Maintenance

As required by warranty, and to achieve optimum performance and service life from your Milnor machine, your machine must be maintained in strict accordance with this instruction.

1. Lubrication Precautions [Document BIUUUM01]



CAUTION [1]: Machine Damage Hazard—Improper lubrication can damage machine components and cause the machine to malfunction.

- Do not mix petroleum and synthetic based lubricants.
- Do not use an unspecified lubricant without consulting the lubricant manufacturer.
- Do not apply grease with a pneumatic grease gun. Use only a hand-operated grease gun.
- Do not over-lubricate.
- Always clean grease fittings before adding grease. Clean off excess grease.
- Ensure that lubricants do not drip onto belts, brake shoes or drums.



WARNING [2]: Entangle and Crush Hazards—Contact with moving components normally isolated by guards, covers, and panels, can entangle and crush your limbs. These components move automatically.

- Lock out and tag out power at the main machine disconnect before servicing, or in accordance with factory service procedures.
- Do not service machine unless qualified and authorized.

1.1. Pumping Grease—Pump grease slowly, taking 10-12 seconds to complete each stroke. A grease gun can build up extremely high pressure which will force seals out of position and cause them to leak.

1.2. Grease Quantity—Apply the quantity of grease called for in the checklist. Over-lubrication can be as damaging as under-lubrication. Where quantities are stated in strokes, one stroke of the grease gun is assumed to provide .0624 fluid oz. (1.77 grams) (by volume) of grease. Therefore, one fluid ounce (28.3 grams) of grease would be provided by 16 strokes of the grease gun. Determine the flow rate of your grease gun by pumping one ounce into a calibrated container. If fewer than 16 strokes are required, all quantities in strokes in the chart should be reduced accordingly, and if more than 16 strokes are required, the number of strokes should be increased. Before starting lubrication, make sure your grease gun is working and that you get a full charge of grease with every stroke.

1.3. Greasing Seals and Bearings—Grease seals and bearings with the cylinder turning at wash speed.



WARNING [3]: Entangle and Crush Hazards—Contact with moving components normally isolated by guards, covers, and panels, can entangle and crush your limbs. These components move automatically.

- Use extreme care when working near moving components.

Grease seals and main bearing as follows:

1. Locate the seal and bearing grease fittings.
2. Enable the clockwise wash output as described in the reference manual.

3. With the cylinder turning, grease the seals and bearings as called for on the “Preventive Maintenance Checklist.”

1.4. Lubricant Specifications—Lubricant specifications are provided in the preventive maintenance checklist. Lubricants should be purchased locally. If a specified lubricant is not available locally, it is permissible to substitute a product that has been specified as equivalent by the lubricant manufacturer. If you cannot obtain either the specified lubricant or a valid equivalent locally, contact the Milnor Service Department for assistance.

2. Centrifugal extractor main bearing and seal greasing instructions



WARNING 4: Entangle and Crush Hazards—“Bypass door interlocks” position bypasses door interlocks and permits access to extractor during both manual and automatic operation. To prevent **SERIOUS INJURY OR DEATH**:

- Use extreme care when working near moving components.
- Never use “Bypass door interlocks” position during normal operation.

Although centrifugal extractors follow the same general seal and bearing grease instructions stated above, they are equipped with a “bypass door switch” (Figure 1), and require a slightly different procedure as follows:

1. Lock out and tag out power to the machine at the wall disconnect.
2. Locate the bypass door switch in the belt box.
3. Move switch to the “By pass door interlocks” position.
4. Remove left side cosmetic door (as viewed from front of machine).
5. Restore power and place machine in a wash step.
6. With cylinder turning, grease the bearings and seals as called for on the “Preventive Maintenance Checklist.”
7. Lock out and tag off power at the wall disconnect.
8. Replace the door and return bypass switch to automatic.
9. Restore power and resume normal operations.

Figure 1: Bypass door switch



3. Centrifugal Extractor Preventive Maintenance

Table 1: Lubricant specifications

Assembly	Components	Specifications
Main bearing (Figure 3)	Seals and bearings	Shell Alvania EP (or equivalent)
Hydraulic system (Figures 2 and 4)	Pivot, hydraulic cylinder and pump grease fittings	Shell Alvania EP (or equivalent)
	Hydraulic fluid reservoir	Shell Tellus 68 (or equivalent)
Hydrocushions (Figure 2)	M7V Cylinder oil	Shell Turbo 220 (or equivalent)
	M9V Cylinder oil	Shell Tellus 32 (or equivalent)
	Grease fittings	Shell Alvania EP (or equivalent)
Motor (Figure 2)	Motor bearing grease fittings (if so equipped)	Shell Alvania EP (or equivalent)
Brake (Figure 3)	Brake reservoir	DOT 3 brake fluid
Conveyor	Grease fittings	Shell Alvania EP (or equivalent)
Optional inflatable ribs (Figure 8)	Rotary coupling	Chevron SRI

Table 2: Centrifugal Extractor Preventive Maintenance Checklist

Components	Action	Frequency (hours of operation)	Figure
General			
Entire machine	Remove soil build-up	Monthly/200 hours	
Motor			
Extract motor (if equipped with grease fittings)	See Note 1 below		Figure 2
Hydrocushions			
Cylinders	Check oil level at plug, add oil if required	Once every 3 months	Figure 2
	Drain and fill	Annually	
Upper and lower ball joint grease fittings	0.12 ounces (3.54 grams), two strokes at eight locations	Monthly	
Drive belts and pulley sheaves			
Drive belts and pulley sheaves	Check belt tension and wear, replace as required (See Notes 3 and 4)	Monthly (See Table 3)	Figure 2
Bearing Housing			
Front bearing grease fittings	Slowly grease: 0.62 ounces (17.7 grams), ten strokes at one location	Monthly (See "Centrifugal extractor main bearing and seal greasing instructions," above and Note 2 below)	Figure 3
Rear bearing grease fittings	Slowly grease: 0.31 ounces (8.8 grams), five strokes at one location		
Seals	Slowly grease: 0.19 ounces (5.31 grams), three strokes at one location		
Foundation			
Anchor bolts and grout	Inspect anchor bolts and grout	Monthly	
Brake			
Pads	Check for wear, replace as required	Monthly	Figure 3
Reservoir	Check levels, add fluid as required		
Hydraulic components			
Pivot	0.12 ounces (3.54 grams), two strokes at two locations	Monthly	Figure 2
Hydraulic cylinders	0.12 ounces (3.54 grams), two strokes at six locations	Monthly	
Shell stops	Check for wear, replace as required	Semi-annually	

Components	Action	Frequency (hours of operation)	Figure
Reservoir level and temperature gauge	Check level, add if below black mark on gauge (non-tilted), operating temperature (120-130 F) (49-54 C)	Daily	Figure 4
Reservoir	Replace fluid, 60 U.S. Gallons (227.12 Liters)	Annually	Figure 4
Filter	Replace	Semi-annually	Figure 4
Filter pressure gauge	Check pressure with machine tilted, 30 - 60 psi (2 - 4 Bar)	Daily	Figure 4
Line pressure gauge	Check pressure with machine tilted, 400-600 psi (27.5 - 41.3 Bar)	Daily	
All hoses/couplings	Check for leaks, cracks and bulges	Monthly	
Pump	See Note 1 below		
Reuse water systems			
Drip pan and tank strainer	Check and clean	Daily	Figure 5
Reuse pump strainer		Weekly	
Drains			
Load chute drain	Check and clean	Daily	Figure 5
Conveyor components			
Bearings	0.12 ounces (3.54 grams), two strokes at nine locations	Monthly	Figure 6
Drive chain	Inspect chain and gears for wear and lubrication	Monthly	Figure 7
Belt	Check belt tracking, slipping and general condition	Daily	Figure 6
Optional inflatable rib			
Rotary coupling	0.12 ounces (3.54 grams), two strokes	Once every 3 months (See Note 5)	Figure 8
Diffusion bag	Clean	Once every 3 months	
Inflatable rib	Check for cracks in ribs	Weekly	
Muffler	Visually inspect for rust particles, replace as needed	Once every 3 months	
	Check air pressure. Replace muffler if required. (See Note 6)	Bi-annually	

Note 1: See "BALDOR MOTOR MAINTENANCE"...MSSM0274AE, in this manual. If motor manufacturers instructions conflict with manual section above, follow the manufacturers instructions. Motors are warranted by the manufacturers, not Milnor.

Note 2: The main bearings are prepacked with lubricant at the factory. Do not add grease for the first 30 days of operation. During the first month of operation and every time the bearings are re-lubricated, surplus grease will seep out of the spring loaded relief fittings after a few hours running time. This is normal. Relief

Centrifugal Extractor Preventive Maintenance

fittings permit excess grease to escape, preventing over-heating problems. Do not replace this excess lubricant. Normal bearings can run hot enough to make it very uncomfortable for a person to hold his hand on the bearing housing for more than a few seconds.

Note 3: Check and tighten the drive V-belts (if required);
After the first 24 hours of operation (three 8 hour days).
After the first 80 hours of operation (ten 8 hour days).
After the first 160 hours of operation (twenty 8 hour days).

Note 4: All V-belts are not alike. "Super" or "High Capacity" V-belts may have considerably higher capacities than "Standard" belts. Sometimes, a particular manufacturer's V-belts is more suitable for a certain application than another manufacturer, in spite of the fact that both manufacturer's V-belts are reputedly "interchangeable." Because of this, it is best to purchase replacement belts from the original manufacturer of the equipment. If you do not wish to do this, we suggest that when you replace the belts, you purchase the exact style and type belts with which the machine was originally equipped. This is the best way to achieve belt life on your replacement belts equal to the life of the original belt. (If you are not satisfied with the life of the original set, you should ask our factory if a better belt has been developed for the specific application).

Note 5: Rotating unions equipped with grease fittings should be lubricated with a good quality ball bearing grease. We recommend Chevron Oil Company SRI grease for temperatures up to 350 F (177 C). Only enough grease should be applied to the ball bearings to replace that which has been dissipated. Over-greasing can be as damaging to the union as under-greasing. Particularly in high RPM applications, grease should be used sparingly.

Note 6: A relief valve in the rib inflation circuit prevents rib damage by bleeding off excess air pressure through a muffler. Test the relief valve by connecting a manometer to the "T" as shown in Figure 8. Verify that the manometer indicates 3.5 - 4.5 inches when the ribs are inflated. Pressures beyond this indicate that the muffler is clogged and must be replaced.

Table 3: Belt Tension Specifications

Belt	Hertz	Deflection (inches)	Initial tension (pounds)	Final tension (pounds)
Main	50 Hz	31/64	10.5 - 14.3	8.1 - 11.0
	60 Hz	15/32		

Figure 2: Hydraulic, Hydrocushion and Motor Maintenance Points

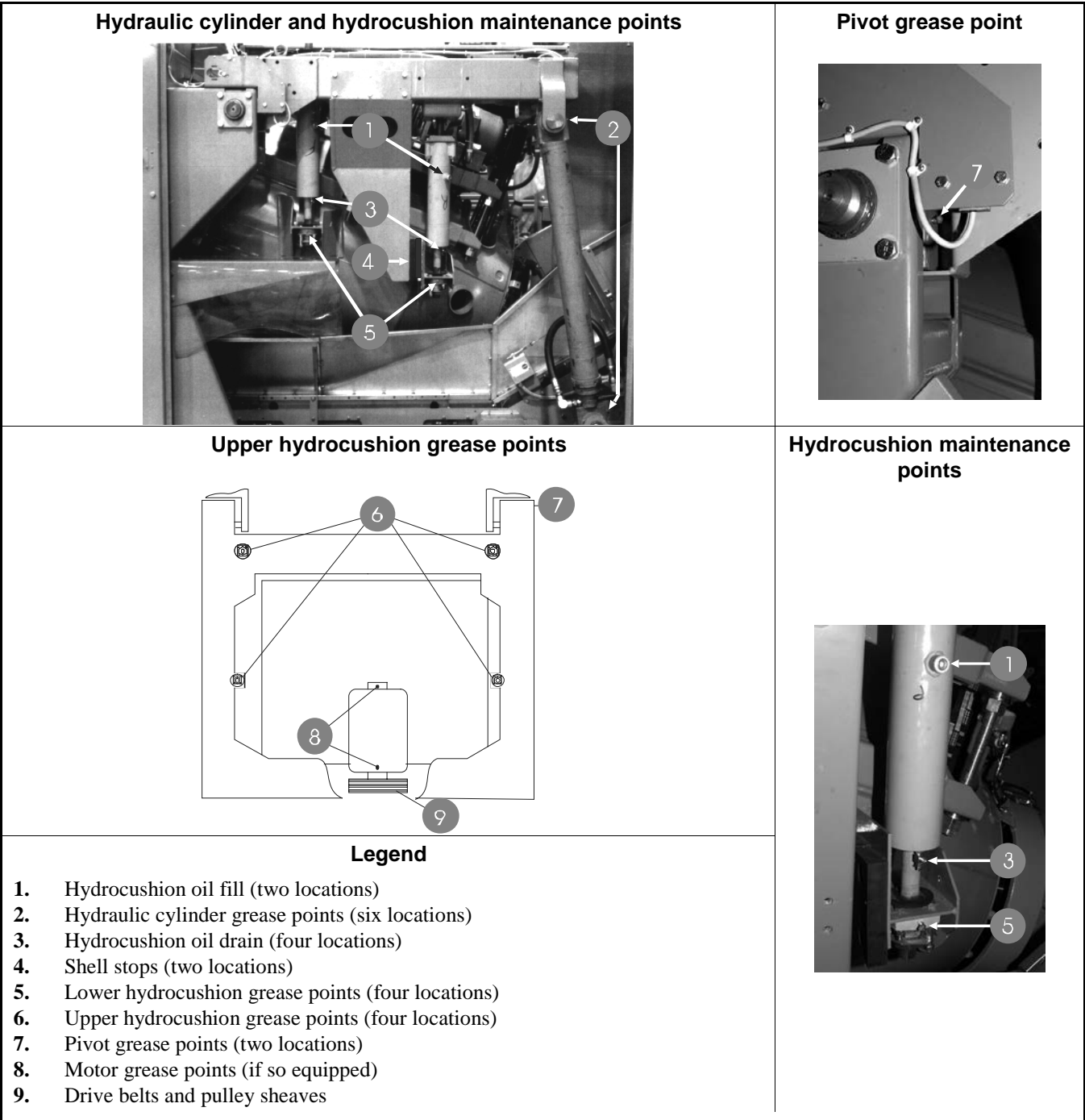


Figure 3: Main Bearing and Brake Maintenance Points

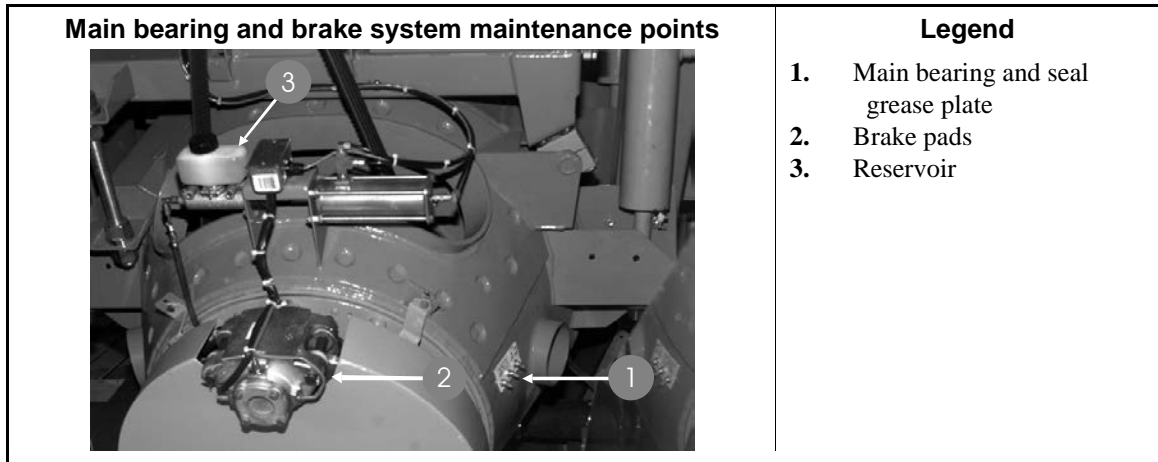


Figure 4: Hydraulic System Maintenance Points

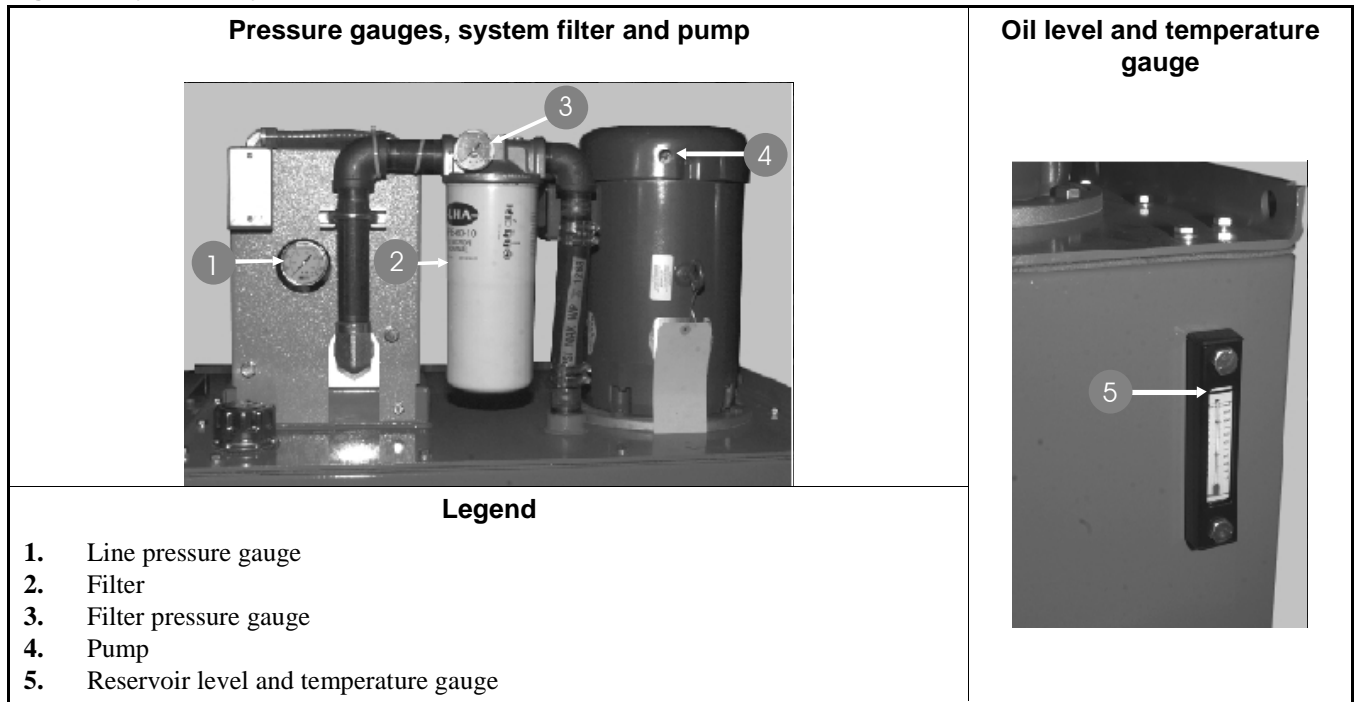


Figure 5: Reuse Water and Drain System Maintenance Points

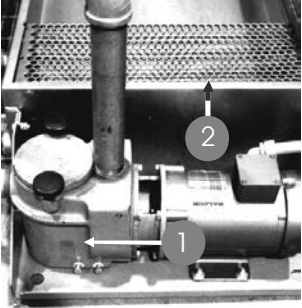
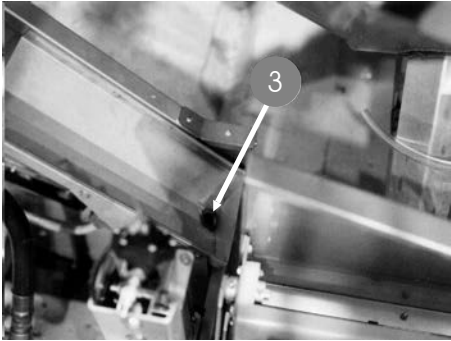

<p>Reuse pump and tank strainers</p> 	<p>Drip pan</p> 
<p>Load chute drain</p> 	<p>Legend</p> <ol style="list-style-type: none"> 1. Pump strainer 2. Tank strainer 3. Drip pan drain 4. Load chute drain

Figure 6: Conveyor Maintenance Points

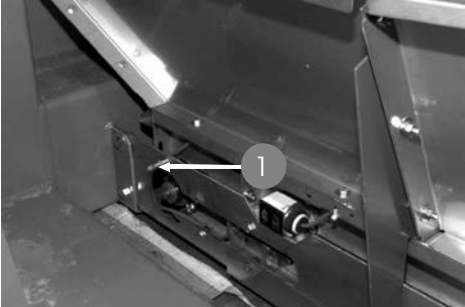

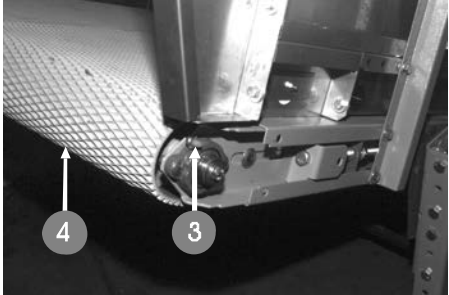
<p>Front roller grease point</p> 	<p>Middle roller and drive chain grease fittings</p> 
<p>Rear roller grease point (2 locations)</p> 	<p>Legend</p> <ol style="list-style-type: none"> 1. Front roller grease point (2 locations) 2. Grease fittings for middle rollers and drive chain (2 locations) 3. Rear roller grease point (2 locations) 4. Belt (2 locations)

Figure 7: Conveyor Drive Chain Maintenance

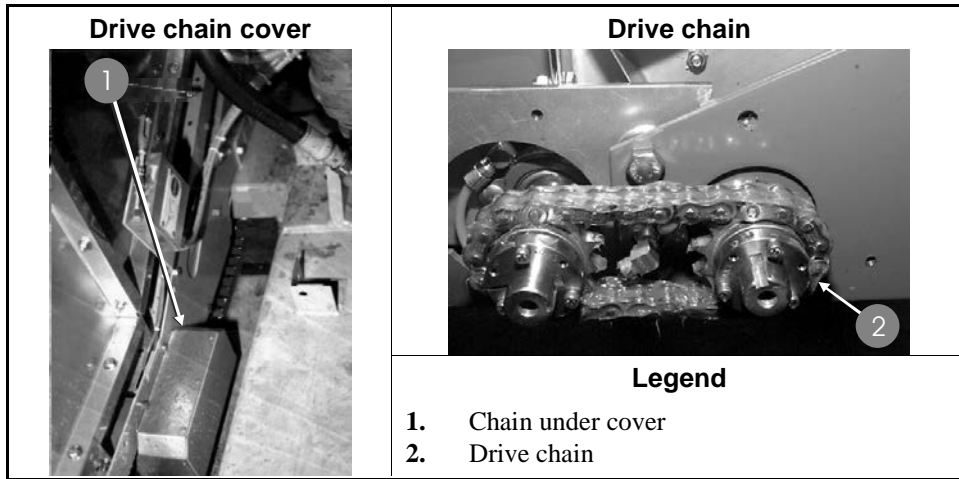
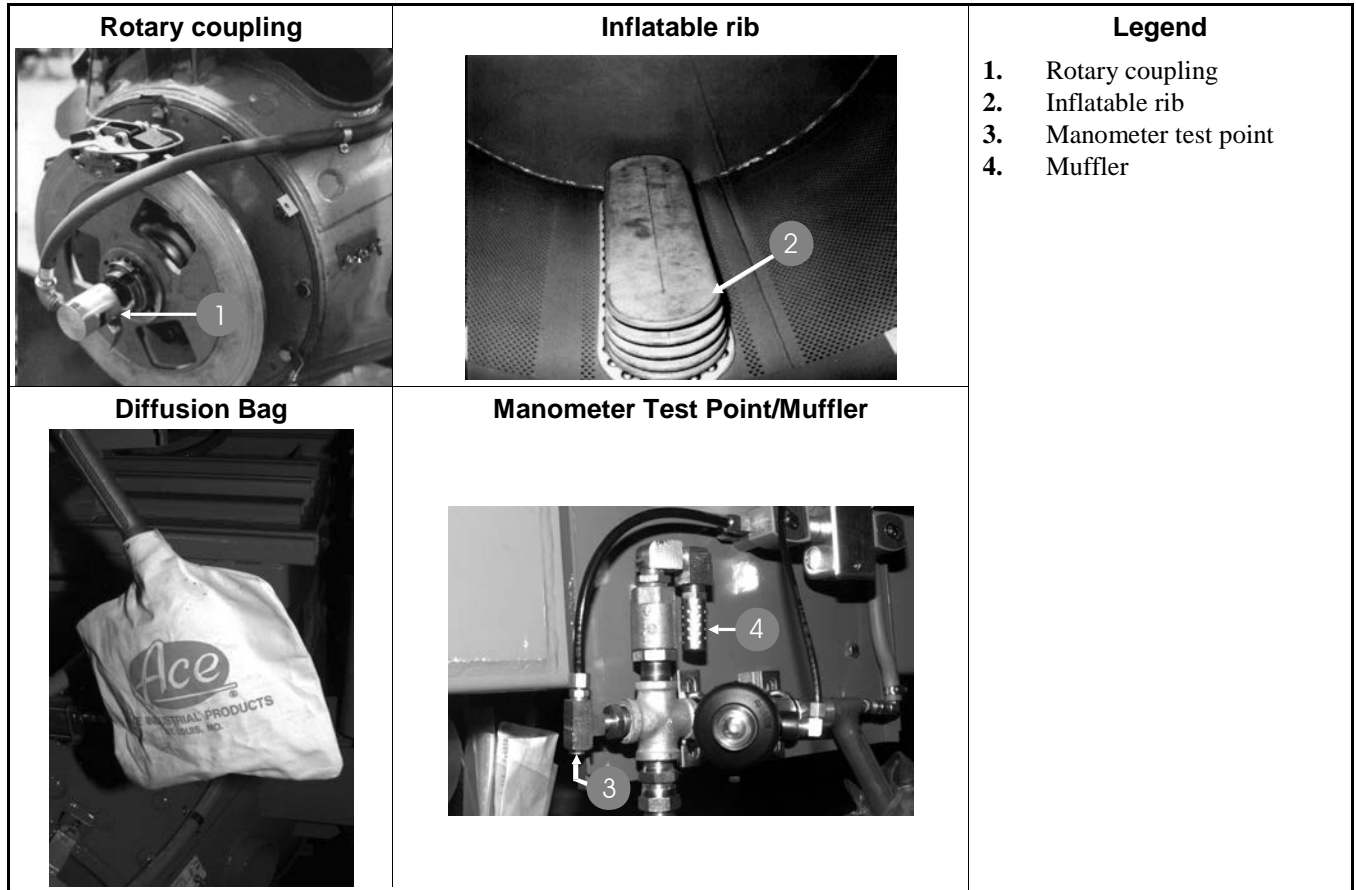


Figure 8: Optional Inflatable Rib Components



— End of BIPV7M01 —

Motor Maintenance



This document uses Simplified Technical English.
Learn more at <http://www.asd-ste100.org>.

This document is for motors used on Milnor® machines that have grease fittings. If the motor manufacturer supplies maintenance instructions, use them. If not, use this document.

NOTICE P1: "Remove power from the machine" means use the necessary safety procedure for your location. In the USA, this is the OSHA lockout/tagout (LOTO) procedure. More local requirements can also apply.



WARNING 2: Risk of Severe Injury—A machine in operation without safety guards can pull in and mutilate your body.

- You must be an approved maintenance technician.
- Replace guards and covers that you remove for maintenance.



WARNING 3: Risk of Severe Injury—The machine has electrical power when the Master switch (M) on the control panel is off or on.

- Remove power from the machine (see Notice P1).

1. Necessary Maintenance

- 1.1. **Keep the motors clean.**—Examine and clean motors each 500 hours of operation or a minimum of each three months. Keep the motors free of dirt, oil, grease, and water. Contamination that prevents good airflow will cause too much heat and cause motor damage.
- 1.2. **Examine a motor that shows unusual symptoms.** —Examine a motor that becomes too hot, makes noise, makes smoke, smells unusual, or opens the circuit breaker frequently. Examine a motor if the inverter gives errors. Make sure that all electrical connections are tight. Make sure that the wire insulation is good. Use a low resistance ohmmeter. Disassemble the motor to clean it fully If necessary.
- 1.3. **Lubricate the motors.**—This document gives the lubricant frequency, quantity, type, and procedure. These are all important. See the related section in document BIIFUM02 which gives the calibration procedures for grease guns.

2. How to Find the Interval and Quantity of Grease to Add

frame code—codes for the standard motor dimensions used by motor manufacturers.

standard interval—the number of hours that a motor can operate in typical conditions before you must add grease.

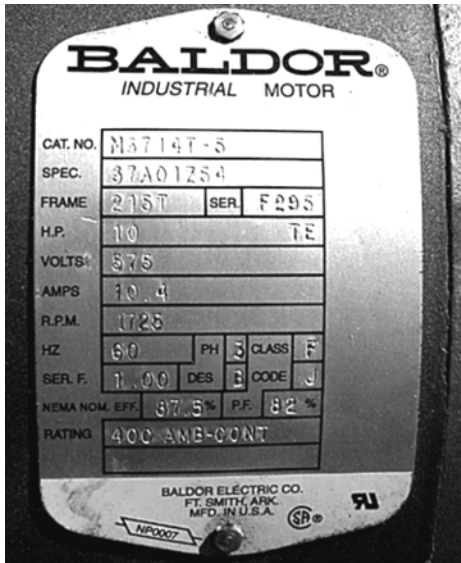
operation conditions—the conditions that can decrease the life of the motor and make it necessary to lubricate more frequently.

rating—One of three levels of operation conditions: typical, bad, very bad.

multiplication number—a decimal number given to the rating. Typical = 1.0, bad = 0.5, and very bad = 0.2.

This section gives the steps you use to find the interval and quantity of grease to add. The examples use the motor data plate shown in [Figure 1](#).

Figure 1: Typical Data Plate on a Motor



1. Find the frame code and RPM on the motor data plate. Example:

$$\text{Frame code} = 215T, \quad \text{RPM} = 1725$$

2. Find the standard interval in [Table 1](#). Example:

$$\text{Standard interval} = 12,000 \text{ hours}$$

3. Find the rating and multiplication number in [Table 2](#) for your worst operation condition. Example: ambient temperature = 102°F (39°C). Moderate contamination.

$$\text{Rating} = \text{bad}, \quad \text{Multiplication number} = 0.5$$

4. Calculate the correct interval (the number of hours of operation before it is necessary to add grease). Example:

$$12,000 \times 0.5 = 6,000 \text{ hours}$$

Where:

12,000 is the standard interval

0.5 is the multiplication number for a rating = bad.

5. Find the quantity of grease for the frame code for your motor in [Table 3](#). You can use the bearing data in the table to do maintenance. Do not use this data to adjust the quantity of grease. Example:

$$\text{grease volume} = 0.16 \text{ ounces (4.7 grams)}$$

$$\text{grease gun cycles} = 2.5$$

Table 1: Standard Interval

NEMA (IEC)** Range of Frame Codes	Interval in Hours for the Given RPM			
	3600 RPM*	1800 RPM*	1200 RPM*	900 RPM*
Up to 215 (132)	5500	12000	18000	22000
254 to 286 (160 - 180)	3600	9500	15000	18000
324 to 365 (200 - 225)	2200	7400	12000	15000
404 to 5000 (280 - 315) 6313 or 6314 bearings	2200	3500	7400	10500
	Roller bearings	1100	1750	3700

* Use this column if this is near or the same RPM as your motor.
 ** Frame codes given by the IEC are shown in parentheses.

Table 2: Operation Condition and Multiplication Number

Operation Conditions*			Rating	Multiplication Number
Maximum Ambient Temperature	Or Atmospheric Contamination	Or Bearing Type		
104°F (40°C)	Clean, not much corrosion	Ball bearing with a groove of large depth	Typical	1.0
122°F (50°C)	Moderate dirt, corrosion	Ball thrust, roller	Bad	0.5
>122°F (>50°C)	Much dirt, abrasive dust, corrosion	n.a.	Very bad	0.1

* The worst condition sets the rating.

Table 3: Grease Quantity (total quantity for all bearings in the motor)

NEMA (IEC) Range of Frame Codes	Largest Bearing Dimension in Range			Quantity of Grease *		Cycles of the Grease Gun
	Category of Bearing	Outer Diameter (mm)	Width (mm)	(Ounces)	(Grams)	
0 thru 215 (132)	6307	80	21	0.16	4.7	2.5
254 to 286 (160 - 180)	6311	120	29	0.32	9.1	5
324 to 365 (200 - 225)	6313	140	33	0.43	12.2	7
404 to 5000 (280 - 315)	NU322	240	50	1.11	31.5	18

* This is the quantity for the two bearings.

3. Grease Types and Procedures

Table 4: Type of Grease

Rating from Table 2	Type of Grease
Typical	Shell Dolium R, Chevron SRI, or equivalent
Bad	
Very Bad	Darmex 707 or equivalent



CAUTION [4]: Damage and Malfunction Risks—Too much grease gun pressure can put grease in the motor and cause electrical components to burn out. If grease touches a brake or a clutch surface, this can cause a malfunction.

- Apply grease carefully.

Apply grease as follows:

1. **Remove power from the machine (see Notice P1).**
2. Clean grease fittings.
3. If the motor has a grease outlet plug, remove it.
4. Add the recommended quantity of grease (See [Item 5](#)). Stop immediately if you see new grease around the motor shaft, wires or the grease outlet plug.
5. If the motor has a grease outlet plug, replace it.

— End of BIUUM03 —

Torque Requirements for Fasteners



This document uses Simplified Technical English. Learn more at <http://www.asd-ste100.org>.

The document about the assembly gives the torque requirements for other fasteners. **If fastener torque specifications or threadlocker requirements in an assembly document are different from this document, use the assembly document.**

Figure 1: The Bolts in Milnor® Equipment

The Marks on Bolt Heads	Legend
	<p>A. SAE Grades 1 and 2, ASTM A307, and stainless steel B. Grade BC, ASTM A354 C. SAE Grade 5, ASTM A449 D. SAE Grade 8 and ASTM A354 BD</p>

1. Torque Values

These tables give the standard dimension, grade, threadlocker, and torque requirements for fasteners frequently used on Milnor® equipment.

Note 1: Data from the Pellerin Milnor® Corporation “Bolt Torque Specification” (bolt_torque_milnor.xls/2002096).

1.1. Fasteners Made of Carbon Steel

1.1.1. Without a Threadlocker

Table 1: Torque Values for Standard Fasteners with Maximum 5/16-inch Diameters and No Lubricant

Dimension	The Grade of the Bolt							
	Grade 2		Grade 5		Grade 8		Grade BC	
	Pound-Inches	N-m	Pound-Inches	N-m	Pound-Inches	N-m	Pound-Inches	N-m
1/4 x 20	66	7	101	11	143	16	126	14
1/4 x 28	76	9	116	13	163	18	--	--
5/16 x 18	136	15	209	24	295	33	258	29
5/16 x 24	150	17	232	26	325	37	--	--

Torque Requirements for Fasteners

Table 2: Torque Values for Standard Fasteners Larger Than 5/16-inch Diameters and No Lubricant

Dimension	The Grade of the Bolt							
	Grade 2		Grade 5		Grade 8		Grade BC	
	Pound-feet	N-m	Pound-feet	N-m	Pound-feet	N-m	Pound-feet	N-m
3/8 x 16	20	27	31	42	44	59	38	52
3/8 x 24	23	31	35	47	50	68	--	--
7/16 x 14	32	43	49	66	70	95	61	83
7/16 x 20	36	49	55	75	78	105	--	--
1/2 x 13	49	66	75	102	107	145	93	126
1/2 x 20	55	75	85	115	120	163	--	--
9/16 x 12	70	95	109	148	154	209	134	182
9/16 x 18	78	106	121	164	171	232	--	--
5/8 x 11	97	131	150	203	212	287	186	252
5/8 x 18	110	149	170	231	240	325	--	--
3/4 x 10	172	233	266	361	376	510	329	446
3/4 x 16	192	261	297	403	420	569	--	--
7/8 x 9	167	226	429	582	606	821	531	719
7/8 x 14	184	249	473	641	668	906	--	--
1 x 8	250	339	644	873	909	1232	796	1079
1 x 12	274	371	704	954	994	1348	--	--
1 x 14	281	381	723	980	1020	1383	--	--
1 1/8 x 7	354	480	794	1077	1287	1745	1126	1527
1 1/8 x 12	397	538	891	1208	1444	1958	--	--
1 1/4 x 7	500	678	1120	1519	1817	2464	1590	2155
1 1/4 x 12	553	750	1241	1682	2012	2728	--	--
1 3/8 x 6	655	888	1469	1992	2382	3230	2085	2827
1 3/8 x 12	746	1011	1672	2267	2712	3677	--	--
1 1/2 x 6	869	1178	1949	2642	3161	4286	2767	3751
1 1/2 x 12	979	1327	2194	2974	3557	4822	--	--

Table 3: Torque Values for Plated Fasteners with Maximum 5/16-inch Diameters and No Lubricant

Dimension	The Grade of the Bolt							
	Grade 2		Grade 5		Grade 8		Grade BC	
	Pound-Inches	N-m	Pound-Inches	N-m	Pound-Inches	N-m	Pound-Inches	N-m
1/4 x 20	49	6	76	9	107	12	95	11
1/4 x 28	56	6	88	10	122	14	--	--
5/16 x 18	102	12	156	18	222	25	193	22
5/16 x 24	113	13	174	20	245	28	--	--

Table 4: Torque Values for Plated Fasteners Larger Than 5/16-inch Diameters and No Lubricant

Dimension	The Grade of the Bolt							
	Grade 2		Grade 5		Grade 8		Grade BC	
	Pound-feet	N-m	Pound-feet	N-m	Pound-feet	N-m	Pound-feet	N-m
3/8 x 16	15	20	23	31	33	44	29	38
3/8 x 24	17	23	26	35	37	49	--	--
7/16 x 14	24	32	37	50	52	71	46	61
7/16 x 20	27	36	41	55	58	78	--	--
1/2 x 13	37	49	56	76	80	106	70	93
1/2 x 20	41	55	64	85	90	120	--	--
9/16 x 12	53	70	81	110	115	153	101	134
9/16 x 18	59	79	91	122	128	174	--	--
5/8 x 11	73	97	113	150	159	212	139	186
5/8 x 18	83	110	127	172	180	240	--	--
3/4 x 10	129	173	200	266	282	376	246	329
3/4 x 16	144	192	223	297	315	420	--	--
7/8 x 9	125	166	322	430	455	606	398	531
7/8 x 14	138	184	355	474	501	668	--	--
1 x 8	188	250	483	644	682	909	597	796
1 x 12	205	274	528	716	746	995	--	--
1 x 14	210	280	542	735	765	1037	--	--
1 1/8 x 7	266	354	595	807	966	1288	845	1126
1 1/8 x 12	298	404	668	890	1083	1444	--	--
1 1/4 x 7	375	500	840	1120	1363	1817	1192	1590
1 1/4 x 12	415	553	930	1261	1509	2013	--	--
1 3/8 x 6	491	655	1102	1470	1787	2382	1564	2085
1 3/8 x 12	559	758	1254	1672	2034	2712	--	--
1 1/2 x 6	652	870	1462	1982	2371	3161	2075	2767
1 1/2 x 12	733	994	1645	2194	2668	3557	--	--

1.1.2. With a Threadlocker

Table 5: Threadlocker by the Diameter of the Bolt (see Note 2)

LocTite Product	Dimension			
	1/4-inch	1/4- to 5/8-inch	5/8- to 7/8-inch	1-inch +
LocTite 222	OK			
LocTite 242		OK		
LocTite 262			OK	
LocTite 272			High temperature	
LocTite 277				OK

Note 2: The acceptable bolt size ranges for various LocTite® threadlocking products is the LocTite manufacturer's **general** recommendation. Specific applications sometime require that a LocTite product is applied to a bolt size outside the ranges shown here. For example, Milnor specifies LocTite 242 for use on certain 1" bolt applications and has confirmed this usage with the LocTite manufacturer. You may see variances such as this in the documentation for specific machine assemblies.

Torque Requirements for Fasteners

Table 6: Torque Values if You Apply LocTite 222

Dimension	The Grade of the Bolt							
	Grade 2		Grade 5		Grade 8		Grade BC	
	Pound-inches	N-m	Pound-inches	N-m	Pound-inches	N-m	Pound-inches	N-m
1/4 x 20	60	7	96	11	132	15	108	12
1/4 x 28	72	8	108	12	144	16	--	--

Table 7: Torque Values if You Apply LocTite 242

Dimension	The Grade of the Bolt							
	Grade 2		Grade 5		Grade 8		Grade BC	
	Pound-feet	N-m	Pound-feet	N-m	Pound-feet	N-m	Pound-feet	N-m
5/16 x 18	11	15	17	23	25	34	22	30
5/16 x 24	13	18	19	26	27	37	27	37
3/8 x 16	20	27	31	42	44	60	38	52
3/8 x 24	23	31	35	47	50	68	--	--
7/16 x 14	32	43	49	66	70	95	61	83
7/16 x 20	36	49	55	75	78	106	--	--
1/2 x 13	49	66	75	102	107	145	93	126
1/2 x 20	55	75	85	115	120	163	--	--
9/16 x 12	70	95	109	148	154	209	134	182
9/16 x 18	78	106	121	164	171	232	--	--
5/8 x 11	97	132	150	203	212	287	186	252
5/8 x 18	110	149	170	230	240	325	--	--

Table 8: Torque Values if You Apply LocTite 262

Dimension	The Grade of the Bolt							
	Grade 2		Grade 5		Grade 8		Grade BC	
	Pound-feet	N-m	Pound-feet	N-m	Pound-feet	N-m	Pound-feet	N-m
3/4 x 10	155	210	240	325	338	458	296	401
3/4 x 16	173	235	267	362	378	512	--	--
7/8 x 9	150	203	386	523	546	740	477	647
7/8 x 14	165	224	426	578	601	815	--	--

Table 9: Torque Values if You Apply LocTite 272 (High-Temperature)

Dimension	The Grade of the Bolt							
	Grade 2		Grade 5		Grade 8		Grade BC	
	Pound-feet	N-m	Pound-feet	N-m	Pound-feet	N-m	Pound-feet	N-m
1 x 8	350	475	901	1222	1272	1725	1114	1510
1 x 12	383	519	986	1337	1392	1887	--	--
1 x 14	393	533	1012	1372	1428	1936	--	--
1-1/8 x 7	496	672	1111	1506	1802	2443	1577	2138
1-1/8 x 12	556	754	1247	1691	2022	2741	--	--
1-1/4 x 7	700	949	1568	2126	2544	3449	2226	3018
1-1/4 x 12	774	1049	1737	2355	2816	3818	--	--
1-3/8 x 6	917	1243	2056	2788	3335	4522	2919	3958
1-3/8 x 12	1044	1415	2341	3174	3797	5148	--	--
1-1/2 x 6	1217	1650	2729	3700	4426	6001	3873	5251
1-1/2 x 12	1369	1856	3071	4164	4980	6752	--	--

Table 10: Torque Values if You Apply LocTite 277

Dimension	The Grade of the Bolt							
	Grade 2		Grade 5		Grade 8		Grade BC	
	Pound-feet	N-m	Pound-feet	N-m	Pound-feet	N-m	Pound-feet	N-m
1 x 8	325	441	837	1135	1181	1601	1034	1402
1 x 12	356	483	916	1242	1293	1753	--	--
1 x 14	365	495	939	1273	1326	1798	--	--
1-1/8 x 7	461	625	1032	1399	1674	2270	1464	1985
1-1/8 x 12	516	700	1158	1570	1877	2545	--	--
1-1/4 x 7	650	881	1456	1974	2362	3202	2067	2802
1-1/4 x 12	719	975	1613	2187	2615	3545	--	--
1-3/8 x 6	851	1154	1909	2588	3097	4199	2710	3674
1-3/8 x 12	970	1315	2174	2948	3526	4781	--	--
1-1/2 x 6	1130	1532	2534	3436	4110	5572	3597	4877
1-1/2 x 12	1271	1723	2852	3867	4624	6269	--	--

1.2. Stainless Steel Fasteners

Table 11: Torque Values for Stainless Steel Fasteners 5/16-inch and Smaller

Dimension	316 Stainless		18-8 Stainless		18-8 Stainless with Loctite 767	
	Pound-Inches	N-m	Pound-Inches	N-m	Pound-Inches	N-m
1/4 x 20	79	9	76	9	45	5
1/4 x 28	100	11	94	11	56	6
5/16 x 18	138	16	132	15	79	9
5/16 x 24	148	17	142	16	85	10

Table 12: Torque Values for Stainless Steel Fasteners Larger Than 5/16-inch

Dimension	316 Stainless		18-8 Stainless		18-8 Stainless with Loctite 767	
	Pound-feet	N-m	Pound-feet	N-m	Pound-feet	N-m
3/8 x 16	21	28	20	27	12	16
3/8 x 24	23	31	22	29	13	18
7/16 x 14	33	44	31	42	19	25
7/16 x 20	35	47	33	45	20	27
1/2 x 13	45	61	43	58	26	35
1/2 x 20	47	64	45	61	27	37
9/16 x 12	59	81	57	77	34	46
9/16 x 18	66	89	63	85	38	51
5/8 x 11	97	131	93	125	56	75
5/8 x 18	108	150	104	141	62	84
3/4 x 10	132	179	128	173	77	104
3/4 x 16	130	176	124	168	75	101
7/8 x 9	203	275	194	263	116	158
7/8 x 14	202	273	193	262	116	157
1 x 8	300	406	287	389	172	233
1 x 14	271	367	259	351	156	211
1-1/8 x 7	432	586	413	560	248	336
1-1/8 x 12	408	553	390	529	234	317
1-1/4 x 7	546	740	523	709	314	425
1-1/4 x 12	504	683	480	651	288	390
1-1/2 x 6	930	1261	888	1204	533	722
1-1/2 x 12	732	992	703	953	422	572

2. Preparation



WARNING [2]: Fire Hazard—Some solvents and primers are flammable.

- Use threadlocker and primers with sufficient airflow.
 - Do not use flammable material near ignition sources.
1. Clean all threads with a wire brush or a different tool.
 2. Remove the grease from the fasteners and the mating threads with solvent. Make the parts dry.

Note 3: Loctite 7649 Primer™ or standard solvents will remove grease from parts.

3. Apply a spray of Loctite 7649 Primer™ or equal on the fasteners and the mating threads. Let the primer dry for one minute minimum.

3. How to Apply a Threadlocker

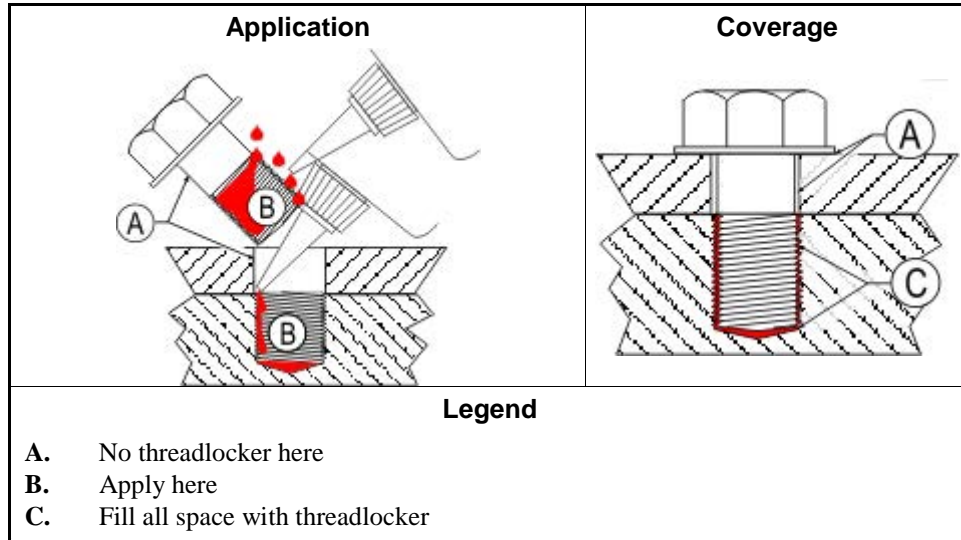


CAUTION [3]: Malfunction Hazard—Heat, vibration, or mechanical shocks can let the fasteners loosen if you do not apply the threadlocker correctly. Loose fasteners can cause malfunctions of the equipment.

- Read the threadlocker manufacturer's instructions and warnings. Obey these instructions.

Apply the threadlocker only to the areas where the fastener threads and the mating threads engage.

Figure 2: Blind Hole



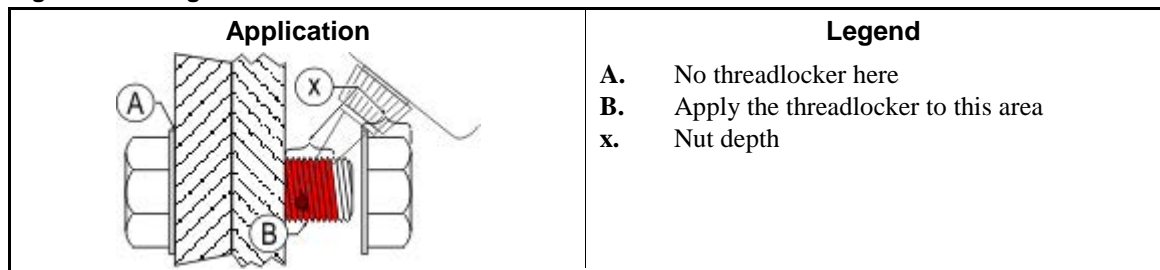
3.1. Blind Holes

1. Apply the threadlocker down the threads to the bottom of the hole.
2. Apply the threadlocker to the bolt.
3. Tighten the bolt to the value shown in the correct table ([Table 5](#) to [Table 11](#)).

3.2. Through Holes

1. Put the bolt through the assembly.
2. Apply the threadlocker only to the bolt thread area that will engage the nut.
3. Tighten the bolt to the value shown in the correct table ([Table 5](#) to [Table 11](#)).

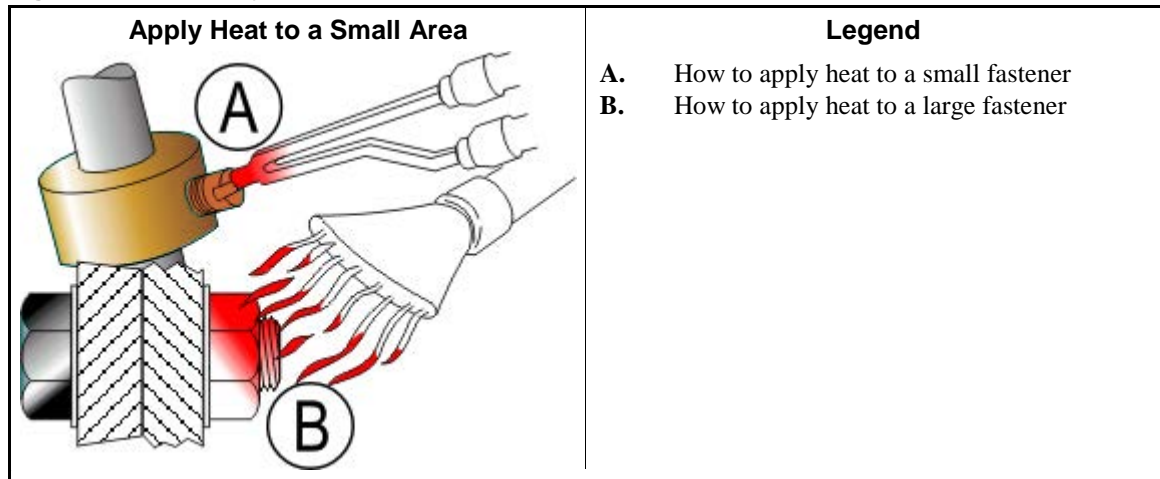
Figure 3: Through Hole



- 3.3. Disassembly**—For high-strength threadlocker, apply heat for five minutes. Disassemble with hand tools while the parts are hot.

For low-strength and moderate-strength threadlocker, disassemble with hand tools.

Figure 4: Disassembly



— End of BIUUM04 —

Disk Brake Maintenance



This document uses Simplified Technical English.

Learn more at <http://www.asd-ste100.org>.

NOTICE P1: "Remove power from the machine" means use the necessary safety procedure for your location. In the USA, this is the OSHA lockout/tagout (LOTO) procedure. More local requirements can also apply.

You can do these types of maintenance on the disk brake:

- do an inspection of the brake as specified in the maintenance schedule,
- replace the friction pads,
- do an overhaul on the calipers,
- replace the hydraulic fluid,
- adjust the connection between the brake cylinder and the air cylinder.

For the first four types of maintenance, you must remove air from (bleed) the hydraulic circuit.

[Section 6](#) tells how to operate the disk brakes. You can use it in some of the types of maintenance in this procedure.

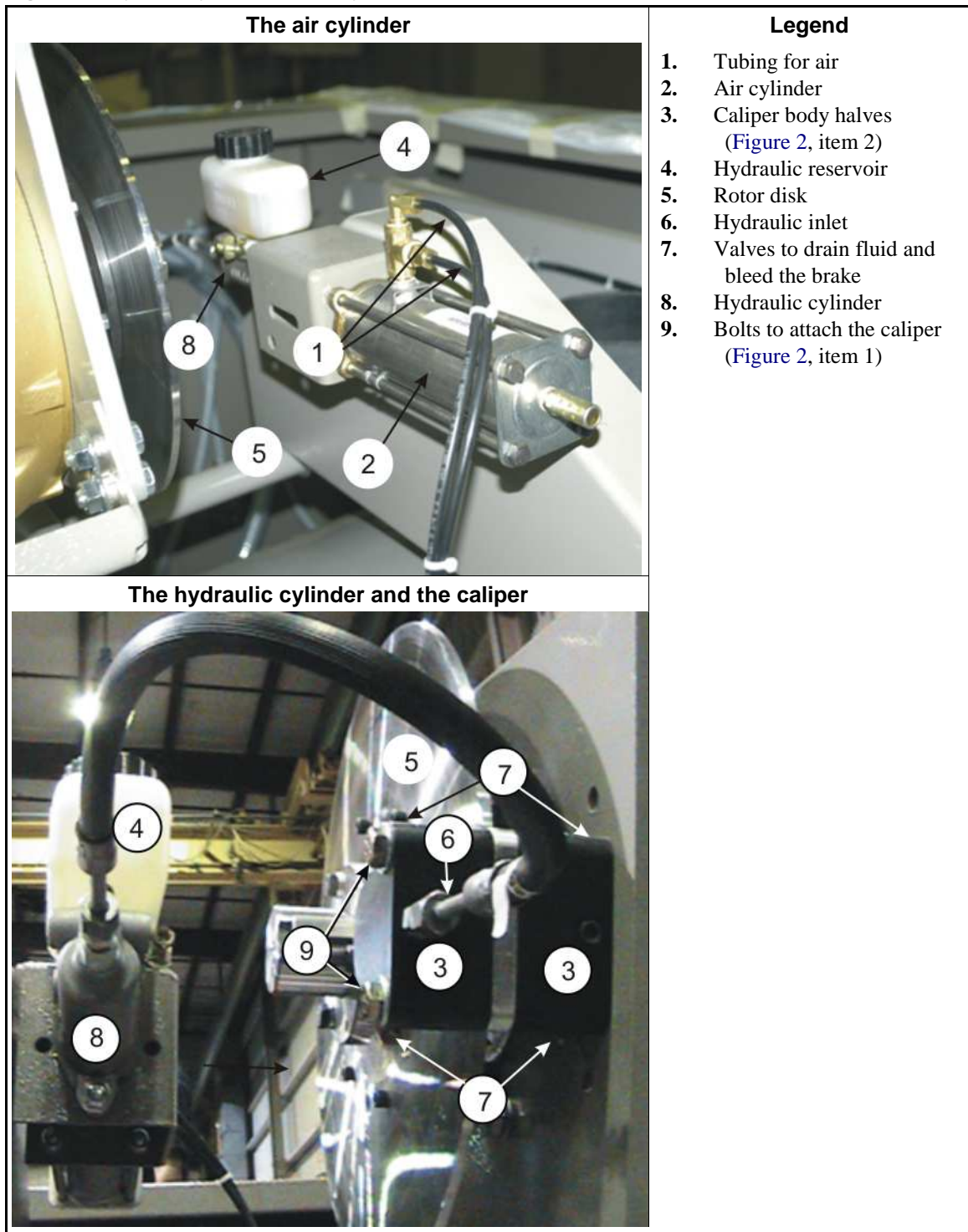


WARNING 2: Risk of injury or death —A machine in operation without safety guards is dangerous.

- You must be an approved maintenance technician.
- Use special caution when this instruction tells you to do work with electrical power on. Remove power from the machine for all other maintenance. Obey safety codes.
- Replace all guards and covers.

Tip: During parts of this procedure when you open up the calipers or hydraulic lines, put a cloth under the calipers to catch hydraulic fluid and parts that will fall. For safety, fully remove spilled hydraulic fluid after brake maintenance. This will help you easily identify leaks.

Figure 1: A typical hydraulic brake system



1. The Inspection of the Brake

Note 1: The brakes shown in this document can look different from your equipment.

Note 2: Do this inspection when the maintenance schedule tells it is necessary. Do this inspection after you replace friction pads or do a caliper overhaul.

- 1.1. Examine the fluid in the reservoir.** —Change the hydraulic fluid if it smells, has contamination, or has an unusual color. See [Section 4](#).

Note 3: Brake fluid can become defective from heat in the brake system. Brake fluid absorbs water from air. Water in the brake system causes corrosion.

If necessary, add new DOT 3 fluid to 0.25 inch (6.35 millimeters) from the top of the reservoir. Follow the precautions on the container.

- 1.2. Examine the rotor disk surface (Figure 1, item 5).** —Replace the disk if it is worn or if it is not flat.
- 1.3. Examine the brake pads (Figure 2, item 4).** —To do this, you will remove/replace the calipers and bleed the hydraulic system. See [Section 3](#) and [Section 4](#).
1. **Remove power from the machine (see Notice P1).**
 2. Remove the bolts ([Figure 1](#), item 9) that attach the caliper halves ([Figure 1](#), item 7).
 3. Remove the caliper halves.
 4. Replace the pads as told in [Section 2](#) if
 - the pads make an unusual noise when you apply the brake
 - if the rotor is worn or damaged
 - if the pad thickness is less than 1/16 inches (2 mm) ([Figure 2](#), item 14) above the mounting screw ([Figure 2](#), item 3). Always replace the two brake pads at the same time.
 5. Put the caliper halves in their positions on the brake assembly. Tighten the mounting bolts to 30 foot-pounds (41 Newton-meters).
 6. Bleed the hydraulic systems as told in [Section 4.4](#).
 7. Supply electrical power to the machine.
- 1.4. Examine the condition of all of the brake system.**
1. Make sure that brake mounting components are tightly installed.
 2. Make sure that fittings are tight. Make sure that there are no leaks.

2. How to Do a Friction Pad Replacement

You must have the necessary replacement friction pads for your machine. Refer to the brake parts document in your machine manual. You will find part numbers for components or overhaul/repair kits. The overhaul/repair kit contains O-rings, pads, and other components.

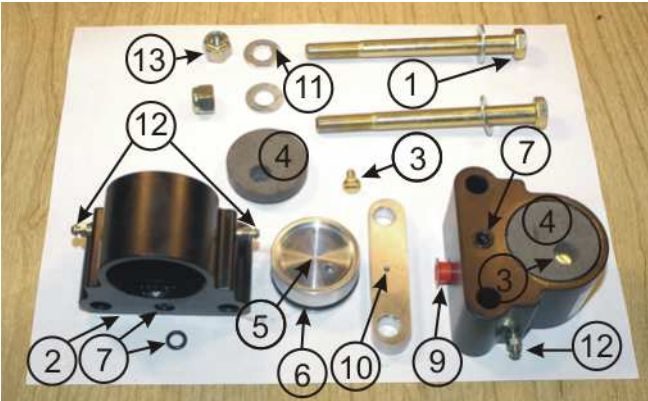


1. **Remove power from the machine (see Notice P1).**
2. Remove the used fluid. See [Section 4.3](#).
3. Remove the two bolts that attach the caliper ([Figure 1](#), item 9) and the two caliper halves ([Figure 1](#), item 3) to get access to the friction pads. Do not disconnect the hydraulic line ([Figure 1](#), item 6).
4. If there are leaks, see [Section 3](#) “How to Do a Caliper Overhaul ” before you continue.
5. Replace each friction pad:
 - a. Remove the brass screw ([Figure 2](#), item 3) that attaches the pad to the piston.
 - b. Attach the new pad to the piston. Tighten the screw.
 - c. Make sure that the screw head is fully in the recess in the pad.
6. Make sure that the connection o-rings are clean and in their positions ([Figure 2](#), item 7).

Disk Brake Maintenance

7. Put the caliper halves in their positions on the brake assembly. Tighten the mounting bolts to 30 foot-pounds (41 Newton-meters).
8. Bleed the brake. See [Section 4 “How to Change Hydraulic Fluid and Remove \(Bleed\) Air from the Brake Circuit”](#).
9. Supply electrical power to the machine.

3. How to Do a Caliper Overhaul

Figure 2: The Caliper Components

<p>The Expanded View (Shows the Piston and the O-rings)</p> 	<p>Legend</p> <ol style="list-style-type: none"> 1. The bolts to attach the caliper (Figure 1, item 9) 2. Caliper body halves (Figure 1, item 3) 3. Brass screw 4. Friction pad 5. Piston 6. The Piston O-ring 7. The connection O-ring and its position 8. Plug for the hydraulic inlet 9. A hydraulic inlet (connected on one caliper, a plug (item 8) on the other) 10. The hole in the spacer 11. Washer 12. One of the four valves to bleed the fluid 13. Nut <p>14. The pad thickness must be more than than 1/16 inches (2 mm) above item 3</p>
<p>The Caliper and the Pad</p> 	
<p>Fittings for the Hydraulic Inlet</p> 	<p>Look at the pad thickness above the top of the screw</p> 

Tip: Hydraulic fluid flows from one caliper to the other caliper. Fluid flows through the connection O-rings (Figure 2, item 7) and the hole in the spacer (Figure 2, item 10). When you disconnect the calipers, hydraulic fluid can flow from the hole at the connection O-rings. Air can get in the line. After you connect the calipers, you must bleed the system.

You must have the necessary kit for the overhaul of your machine. Refer to the brake parts document in your machine's manual.

1. **Remove power from the machine (see Notice P1).**
2. Get access to the caliper halves (see [Section 2](#)).
3. Do an overhaul on each caliper:
 - a. Remove and discard the connection O-rings ([Figure 2](#), item 7) on the caliper bodies.
 - b. Apply compressed air to the fitting for the hydraulic inlets (see [Figure 2](#), item 8) to push the pistons out.
 - c. Replace the piston O-rings ([Figure 2](#), item 6).
 - d. Put the pistons in the caliper body. Carefully tap the pistons with a wood or rubber hammer to install it.
 - e. Replace the connection O-rings. ([Figure 2](#), item 7)
 - f. Replace the friction pads (see [Section 2](#)).
4. Replace the caliper halves as specified in [Section 2](#).
5. Bleed the brake circuit (see [Section 4](#)).
6. Supply electrical power to the machine.

4. How to Change Hydraulic Fluid and Remove (Bleed) Air from the Brake Circuit

4.1. Risks and Precautions



WARNING [3]: Risk of injury —Machine power must be on for these procedures.

- Stay away from operating mechanisms.



CAUTION [4]: Risk of injury and damage —This procedure releases pressurized brake fluid.

- Keep brake fluid out of your eyes and mouth. Wear eye protection.
- Follow procedures carefully to prevent damage to the face of the disk or the pistons.



CAUTION [5]: Risk of malfunction . —Air in hydraulic fluid will compress. Compressed air in the brake line will cause brake malfunctions.

- Remove (bleed) air from the brake circuit before you operate the machine.

4.2. Requirements —These personnel and items are necessary for this procedure:

- two technicians
- an 8-ounce container of new brake fluid
- Alternative procedures to remove air and used brake fluid:
 - » a suction pump (faster procedure) (see [Figure 3](#))
 - » with pressure in the hydraulic cylinder and gravity (see [Figure 4](#))

Tip: The Vacula suction pump can do the work more quickly than by gravity and pressure in the hydraulic cylinder. It is also cleaner because all of the hydraulic fluid goes into the container supplied. It helps you not spill the hydraulic fluid.

- If you use a suction pump as shown in [Figure 3](#), follow the manufacturer's instructions.
- If you use the tools as shown in [Figure 4](#), follow the instructions in [Section 4.3](#) and [Section 4.4](#).

Figure 3: Pumps Used to Remove Hydraulic Fluid Quickly

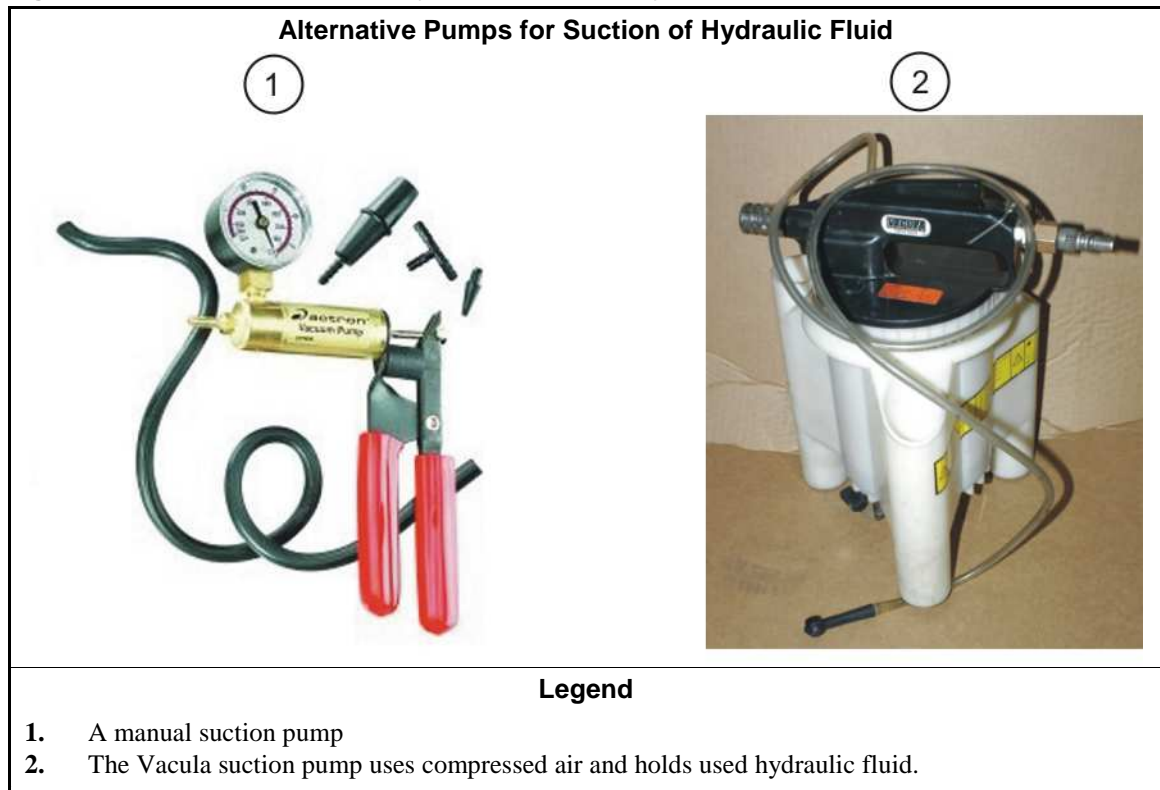
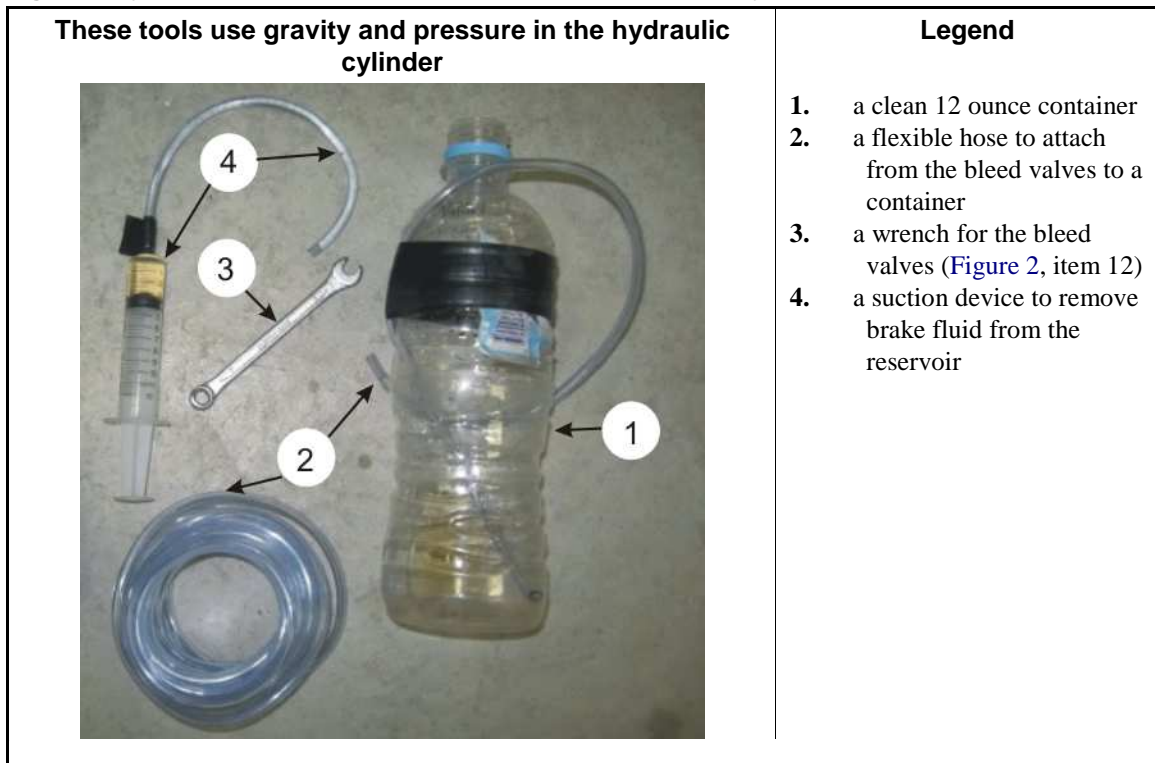


Figure 4: Typical Tools to Remove Air (Bleed) Brakes and Used Hydraulic Fluid



4.3. Use the tools in Figure 4 to remove the used hydraulic fluid and clean the line. —Do these steps:

1. Use a suction tool (Figure 4, item 4) to remove the used fluid from the reservoir. Clean the contamination.
2. Connect the tubing (Figure 4, item 2) and container (Figure 4, item 1) to the valve on the caliper (Figure 1, item 7).
3. Open the valve.
4. Add new fluid to flush out the lines.
5. Apply/release the brake (See Section 6) approximately 5 to 15 times. This will flush the used fluid out of the lines.
6. Close the valve.

Note 4: These steps will cause air to go into the line.

4.4. Add new hydraulic fluid and remove (bleed) air from the brake circuit.

Note 5: This procedure uses pressure in the hydraulic cylinder and the tools in Figure 4.

1. Fill the reservoir with new DOT 3 brake fluid. When you do the remaining steps, continue to add new fluid to the reservoir. Do not let the reservoir become more than half empty. You must make sure that the reservoir has fluid to prevent air flow into the system from the reservoir.
2. Apply electrical power to the machine. Release the brake.
3. See the part of the machine reference manual that tells how to operate the outputs manually.

4. Put a small quantity of new brake fluid (approximately inches (50 mm)) in the 12 ounce container (Figure 4, item 1).
5. Do these steps for each bleed valve (Figure 1, item 1) . Two technicians are necessary. This will move the fluid in one direction and push air out of the line:
 - a. Attach a clean tube to the valve. Put the other end in the container (Figure 4, item 1) below the fluid.
 - b. Make sure that the reservoir is full of fluid.
 - c. Apply the brake (See section 6).
 - d. Open the bleed valve. (Figure 2, item 12)
 - e. Look for air bubbles in the container when you push the air and fluid out through the tube.
 - f. Close the valve.
 - g. Release the brake.
 - h. Continue the steps b through g until no more air comes out of the line.
6. Add fluid to the top of the reservoir. Replace the cap.
7. Operate the brake many times. Make sure that it operates correctly.

5. How to Adjust the Connection between the Brake Cylinder and the Air Cylinder

If you removed the brake cylinder or the air cylinder, you must adjust this connection.

Figure 5: The Connection between the Brake Cylinder and the Air Cylinder

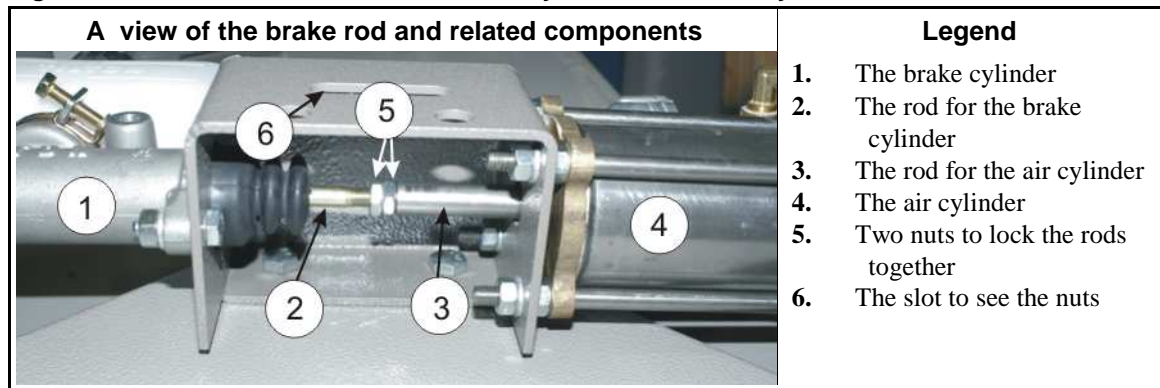
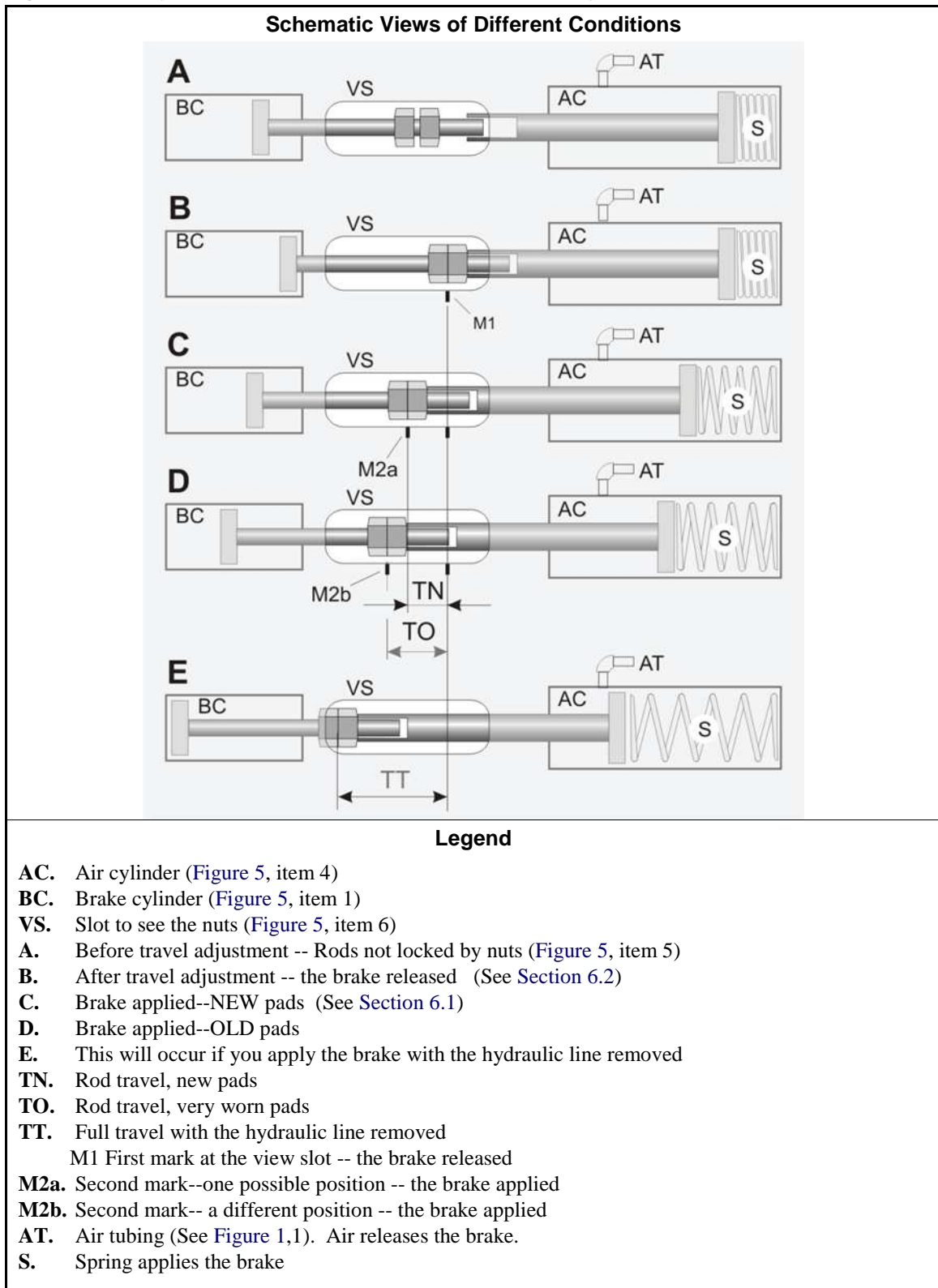


Figure 6: The Adjustment between the Brake Rod and the Air Cylinder



5.1. Adjust for maximum rod travel.

1. Operate the master switch to energize control power.
2. Make sure that the air pressure that releases the brake (Figure 7, item 1) is 85 -100 PSI (5.95 - 07.0 kg/cm-cm).
3. Make sure that the nuts that lock the rods together (Figure 5, item 5) are loose.
4. Release the brake (see Section 6). Let the air cylinder rod fully retract into the air cylinder as shown in Figure 6, A.
5. Turn the brake rod into the air cylinder rod until the brake rod comes out of the brake cylinder fully. See Figure 6, B.
6. Lock the brake rod (Figure 5, item 2) to the air cylinder rod (Figure 5, item 3) with two nuts (Figure 5, item 5).

5.2. Make sure that the brake will continue to operate while the pads wear.

1. Release the brake. On the view slot, put a mark at the position of the lock nuts. (Figure 6, item M1).
2. Apply the brake. See Section 6.
3. Put a mark at the position of the lock nuts when the brake is applied. This can be at position M2a, M2b, or between M2a and M2b. When the pads wear this position will move.
4. Make sure that the distance the rod moves when you apply the brake is 0.75 to 1.0 inches (19-25 mm). If the travel is more than this, the brake piston can hit the mechanical stop before the brake engages fully. This condition is shown in Figure 6 , E (dimension TT).

6. Operation of Brake Systems

Look at the electrical schematics of your machine to find how your brake is controlled. Some machines release the brake when you close the door. Some machines have a control relay to release or apply the brake.

6.1. How to Apply the Brake for Machines with a "Break Release" Output

1. Turn the "brake release" control output off to de-energize the air valve to remove air pressure to the air cylinder (Figure 1, item 1).
2. With no air pressure, a spring in the air cylinder will apply force to the hydraulic cylinder (Figure 1, item 8). This will apply pressure to the brake pads (Figure 2, item 4) against the rotor disk (Figure 1, item 5). (Figure 6, item C,D)

Note 6: If electrical power or compressed air is missing, hydraulic pressure will apply the brake.

6.2. How to Release the Brake for Machines with a "Brake Release" Output

1. Turn the control output called "brake release" on to energize the air cylinder valve.
2. Air pressure compresses the spring and releases the brake. (Figure 6, item B)

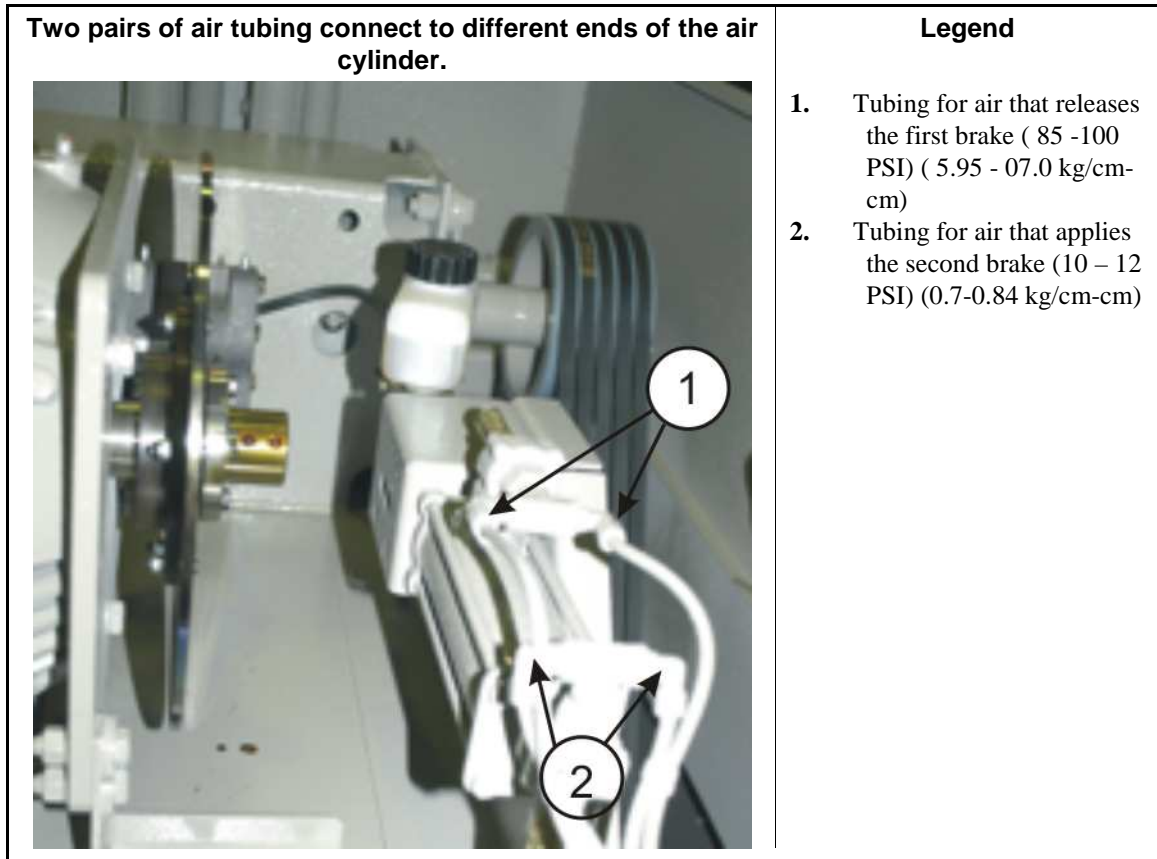
6.3. How to Apply and then Release the Brake Quickly —There are two air tubes at (Figure 1, item 1). One supplies compressed air from an air valve. The other sends this compressed air to a pressure switch. If you remove one of the two tubes when compressed air is there, you will apply the brake.

1. Disconnect the air tubing (Figure 1, item 1).

2. Turn the "brake release" output on. The air valve will supply compressed air to one of the tubes. (Figure 1, item 1).
3. Quickly move one of the compressed air tubes (Figure 1, item 1) on and off the air cylinder.
4. After you complete this procedure, connect the air tubing.

6.4. How the Brake Operates on Divided Cylinder Machines

Figure 7: A Typical First and Second Brake on a Divided Cylinder Machine



- On divided cylinder machines, two pair of air tubes connect to different ends of the air cylinder.
- When the cylinder turns, air pressure at Figure 7, item 1 compresses the spring and releases the brake.
- When you operate the stop control, air pressure at 1 is removed. Then the spring in the air cylinder applies the brake.
- If you open the door, the 2nd brake is applied. Then the air pressure at Figure 7, item 2 and the spring apply the brake.

6.5. The Second Brake —If your machine has a second brake which uses air pressure and spring pressure, it will have a pressure regulator. Make sure that you adjust the air pressure of the second brake (Figure 7, item 2) to 10 – 12 PSI (0.7-0.84 kg/cm-cm).

— End of BIEUUM01 —

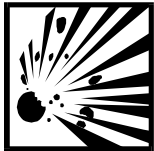
SERVICING AIR CYLINDERS

This is the general procedure for rebuilding an air cylinder using a Milnor[®] furnished repair kit, once the air cylinder has been removed from the machine. See the specific air cylinder and major assembly parts drawing(s) for component identification and removal/replacement information.

Maintenance procedures require:

- Two threaded rods and nuts, twice the length of the tie bolts.
- The appropriate repair kit.

▲ CAUTION ▲



EXPLOSION HAZARD—Spring tension can cause air cylinder to burst apart with great force during disassembly. You can be struck by air cylinder parts.

☞ **Follow maintenance instructions carefully.**

☞ **Wear eye protection.**

NOTE: Use a new locknut when re-assembling air cylinder (see the appropriate parts drawing).

1. Replace two diagonally opposite tie bolts with threaded rods and nuts as shown in FIGURE 1.
2. Tighten nuts on the threaded rods until they contact the air cylinder.
3. Remove the other two tie bolts and the nuts, washers, clips, and actuators from the external end of piston stem.

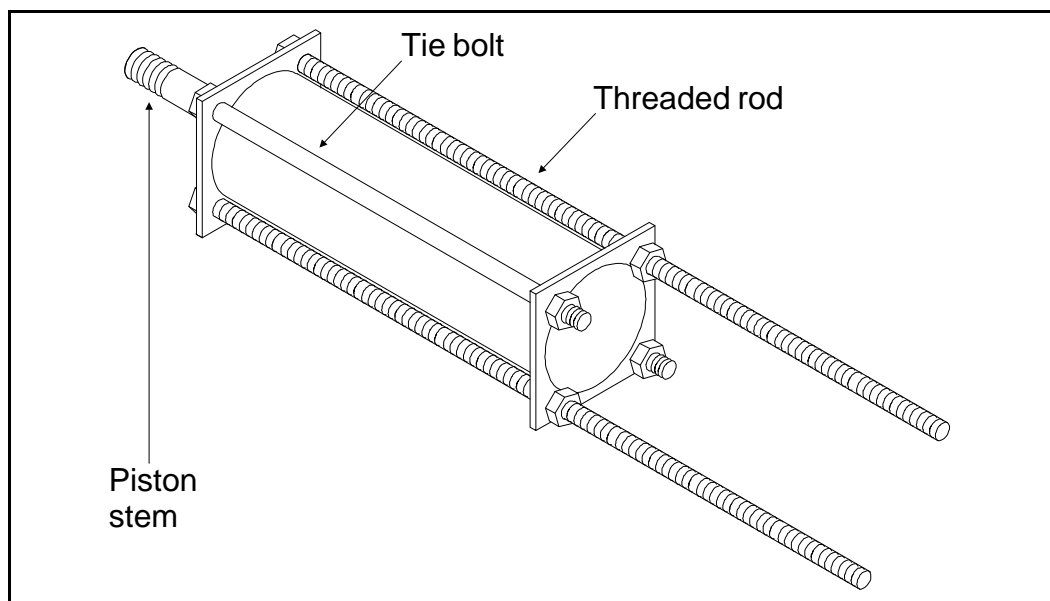


FIGURE 1 (MSSM0130AE)
Using Threaded Rods

- Loosen nuts on threaded rods evenly, permitting cylinder heads to separate. Use only a few turns on one nut before moving to the other one. Continue until springs have no tension.

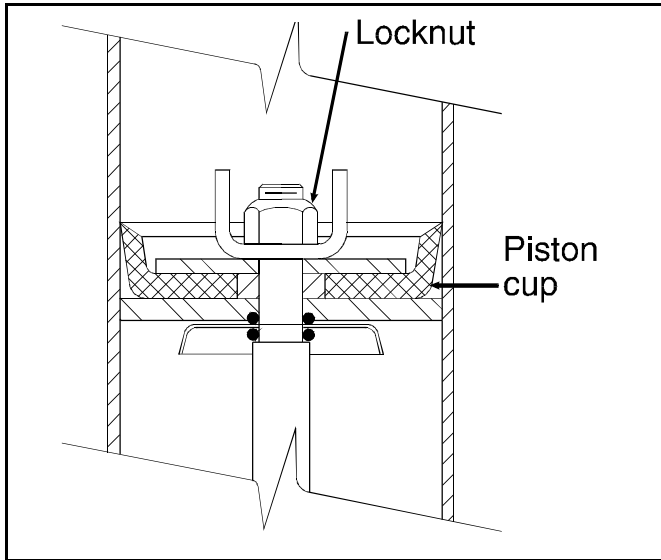


FIGURE 2 (MSSM0130AE)
Correct Piston Cup Shape

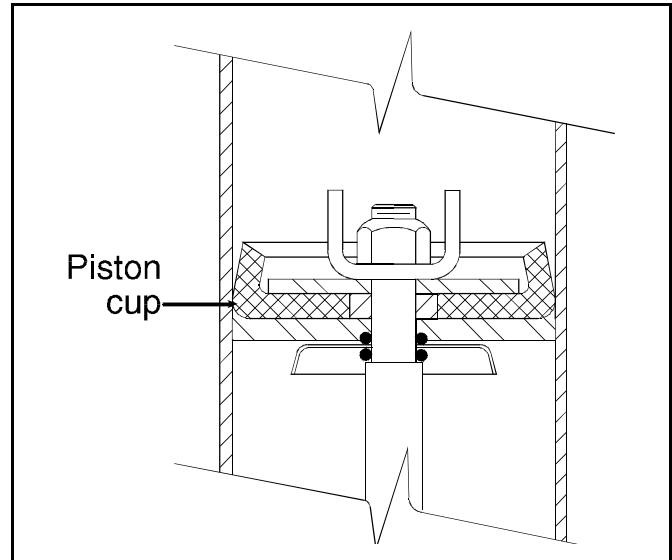


FIGURE 3 (MSSM0130AE)
Distorted Piston Cup Shape

- Note position and orientation of piston cup(s), washers, and springs. Replace worn parts, then reassemble in reverse order. Tighten locknut until it is just barely possible to turn the piston cup and washer assembly on the stem. Correct piston cup shape is shown in FIGURE 2. **DO NOT** overtighten, as this causes the piston cup to deform to the shape shown in FIGURE 3 and may cause piston to bind in cylinder.

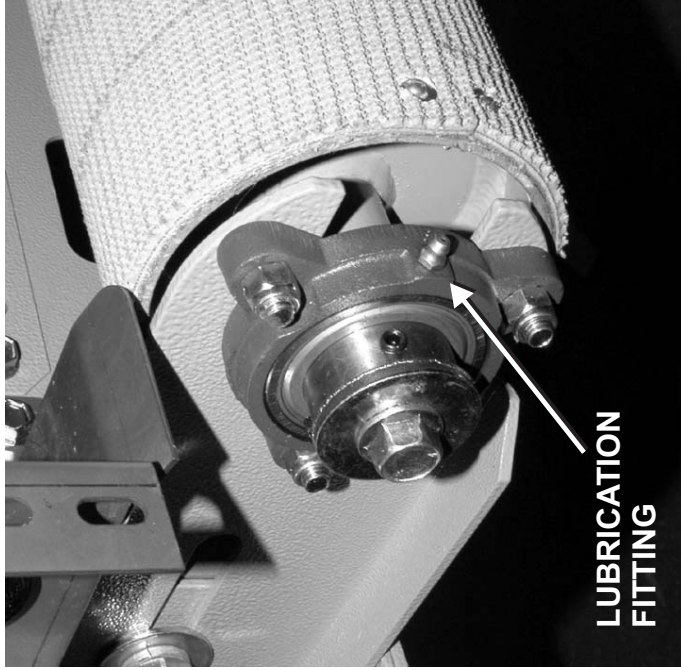
Conveyor Lubrication & Chain Adjustments
Flatbelt, Load Conveyors & Extractor Conveyors

BMP070001/2007042A
(Sheet 1 of 2)

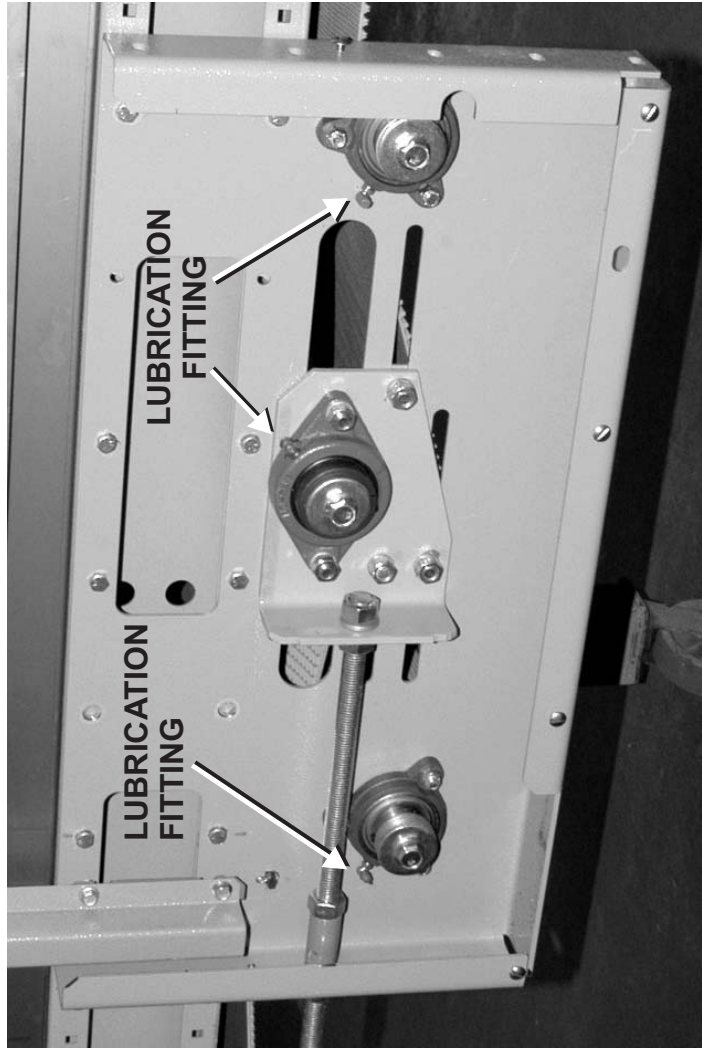
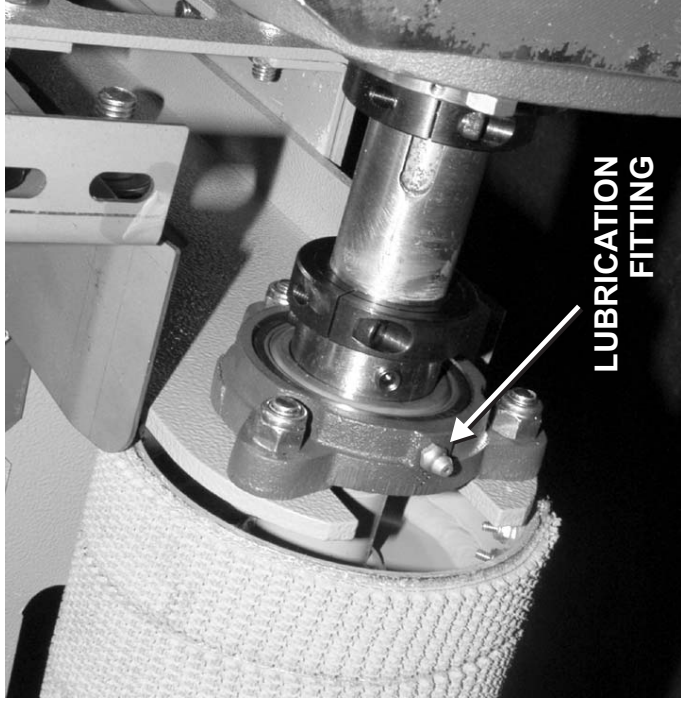


Pellerin Milnor Corporation
P. O. Box 400, Kenner, LA 70063-0400

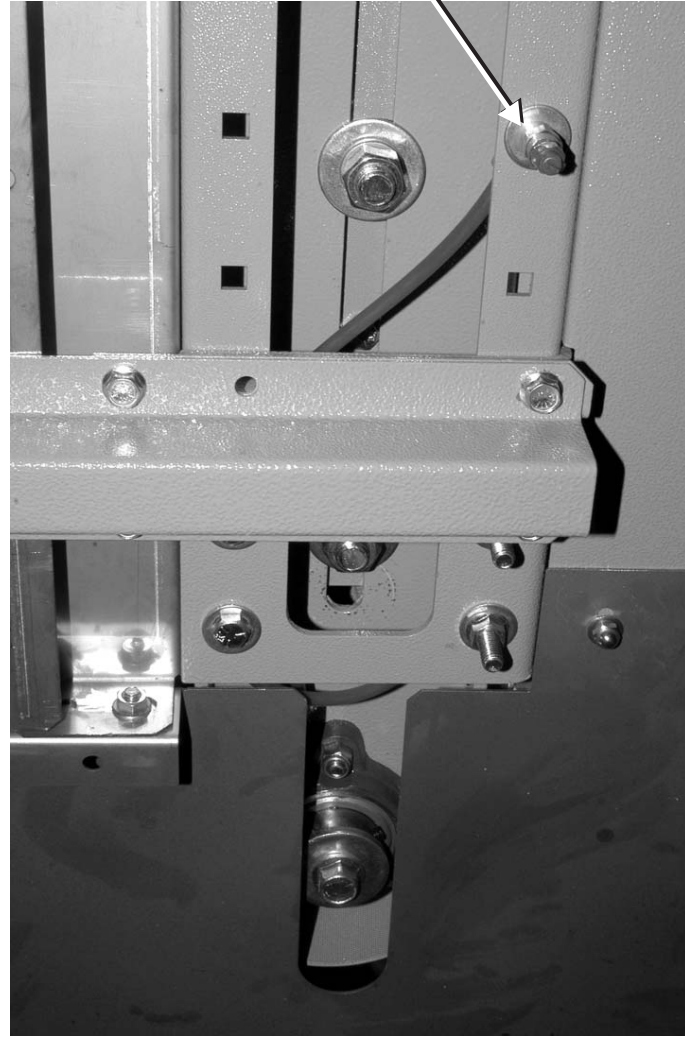
Litho in U.S.A.



TYPICAL: FLATBELT CONVEYORS



TYPICAL: UNDERDRIVE



TYPICAL: LOAD CONVEYORS

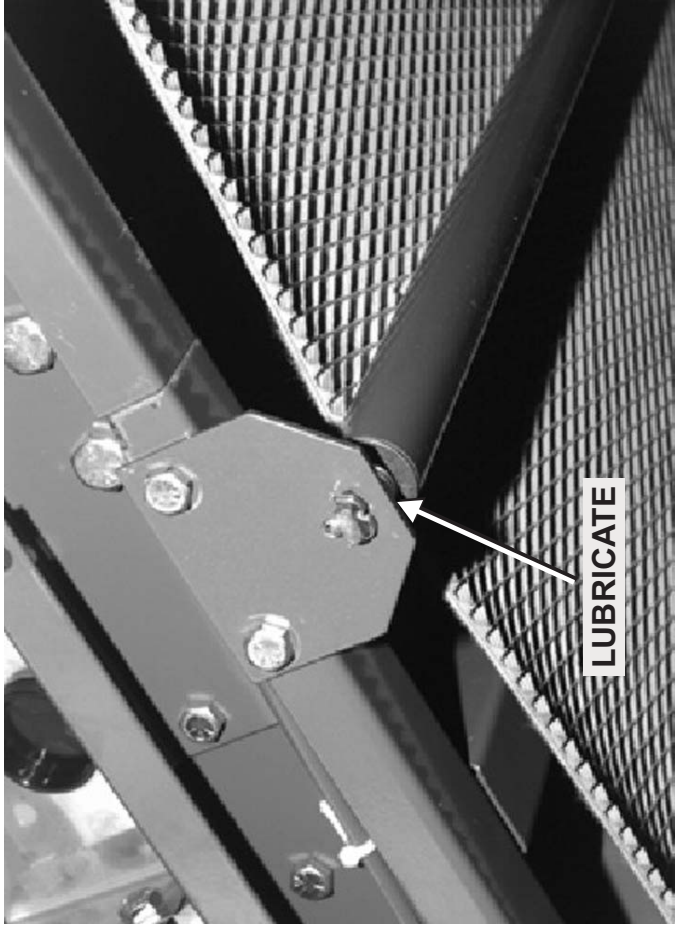
CONVEYOR LUBRICATION:

Every three months, all CONVEYOR ROLLER BEARINGS should be lubricated with bearing lubricant, Shell Alvania EP2 Lithium Grease or equivalent, using a hand pressure grease gun. Lubrication fittings are located on the bearings when they are easily accessible or they are remotely located to a position on the conveyor bed frame, if the bearing cannot be reached easily.



Pellerin Milnor Corporation
 P. O. Box 400, Kenner, LA 70063-0400

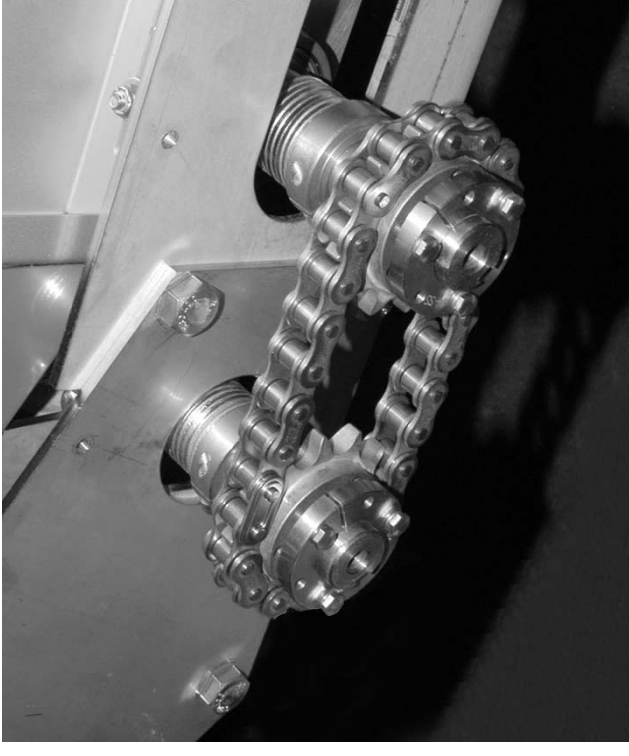
Litho in U.S.A.



TYPICAL: IDLER ROLLER

CHAIN LUBRICATION:

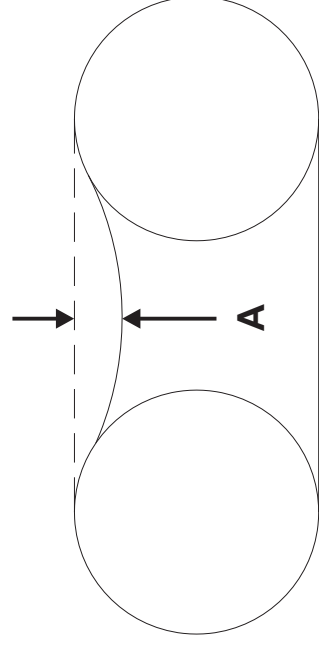
Every thirty days of operation, **CHAIN DRIVES** should be lubricated with bearing lubricant, Shell Alvania EP2 Lithium Grease or equivalent. Chain drives are covered by a safety cover and their lubrication fitting are remotely mounted where they are easily accessible.



CHAIN ADJUSTMENTS:

Every thirty days of operation, **CHAIN DRIVES** should be checked for proper adjustment.

A = 0 - .125" [0- 3mm] New Chain
A= .125" - .25" [3mm - 6mm] After 48 hours



Conveyor Adjustment Procedures Flatbelt & Load Conveyors

BMP820015/96322V
(Sheet 1 of 3)



Pellerin Milnor Corporation
P. O. Box 400, Kenner, LA 70063-0400

BMP820015/96322V (1 of 3)

Litho in U.S.A.

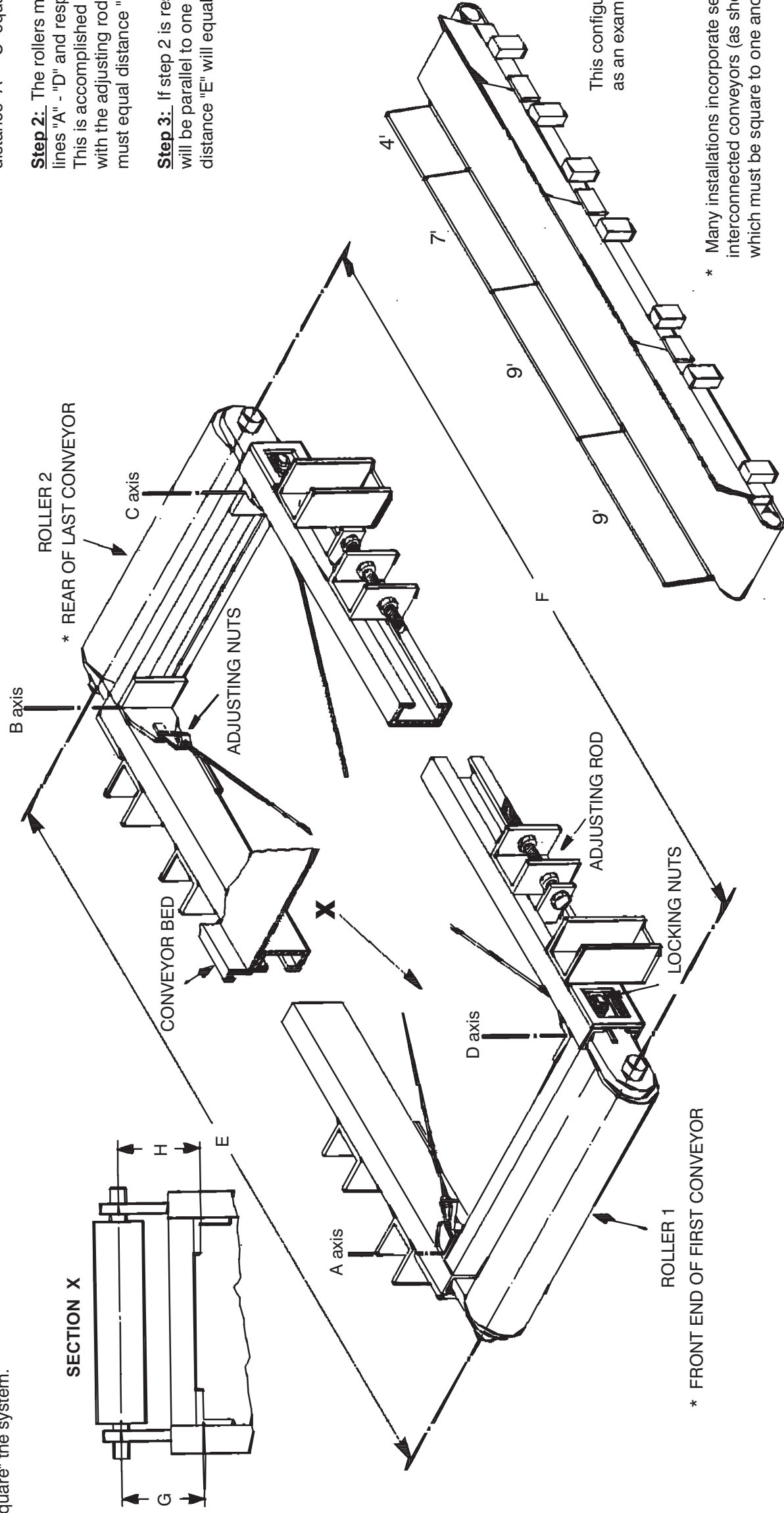
Comments:

To provide optimum durability of the conveyor belt, it is essential that the conveyor is properly "squared". These instructions define the procedures to "square" the system.

Step 1: The conveyor frame must be "square". This is accomplished by adjusting the tie rods between points "A" - "C" and "B" - "D". The frame is "square" if and only if met: distance "A" - "C" equals distance "B" - "D".

Step 2: The rollers must be parallel to the lines "A" - "D" and respectively "B" - "C". This is accomplished by moving the rollers with the adjusting rods. Therefore distance "G" must equal distance "H".

Step 3: If step 2 is respected the rollers will be parallel to one another, therefore distance "E" will equal distance "F".



* Many installations incorporate several interconnected conveyors (as shown above) which must be square to one another.

Conveyor Adjustment Procedures

Flatbelt & Load Conveyors

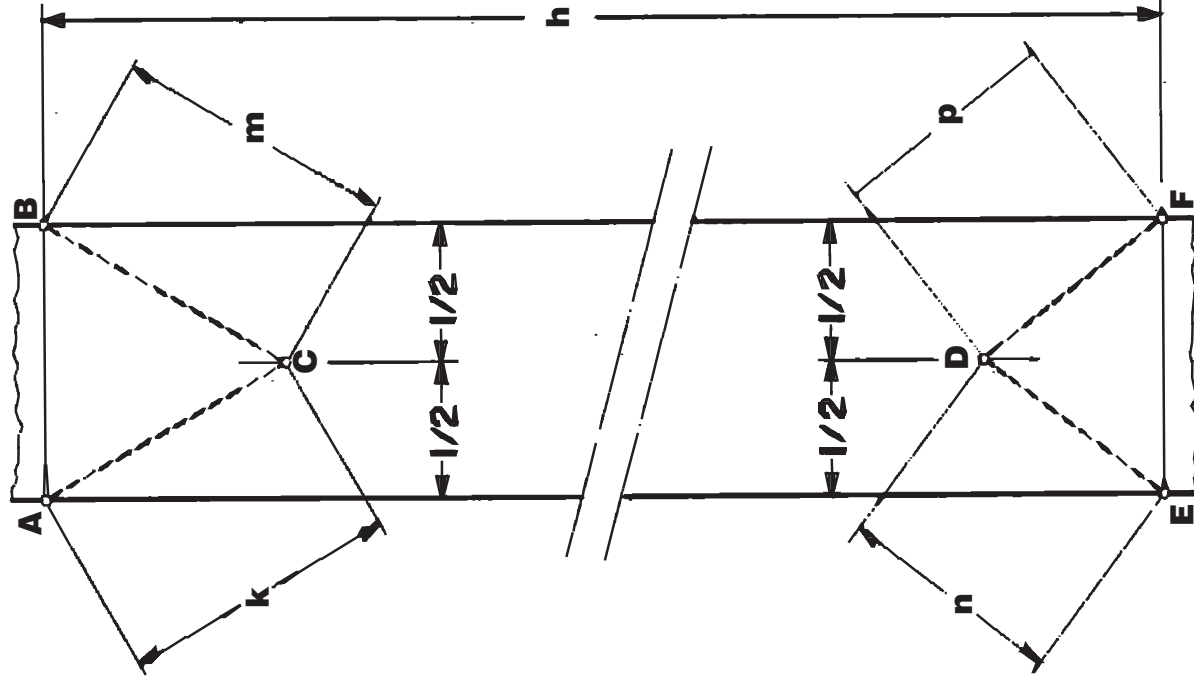
BMP820015/96322V
(Sheet 2 of 3)



Pellerin Milnor Corporation
P. O. Box 400, Kenner, LA 70063-0400

BMP820015/96322V (2 of 3)

Litho in U.S.A.



Step 1: At some point well back from the end of the belt, measure and carefully mark a point (C) at the exact center of the belt width.

Step 2: Measure from this centerpoint two equal lengths (k and m) and mark points (A and B) along the edges and near the end of the belt. Be sure length "k" equals length "m".

Step 3: Measure the total desired length (h) from point "B" to point "F" and mark that point.

Step 4: At some point well back from this end of the belt, mark a point (D) at the exact center of the belt width.

Step 5: Repeat step 2 to find point "E". Be sure that length "n" equals length "p".

Step 6: Cut along lines "A" - "B" and "E" - "F". Cuts must be straight so that the ends may be laced together without causing the belt material to warp.

(THIS PROCEDURE TO BE USED IF A BELT IS TO BE CUT AND LACED IN THE FIELD.)

Conveyor Adjustment Procedures Flatbelt & Load Conveyors

BMP820015/96322V
(Sheet 3 of 3)



Pellerin Milnor Corporation
P. O. Box 400, Kenner, LA 70063-0400

BMP820015/96322V (3 of 3)

Litho in U.S.A.

Step 1: Check the conveyor frame to make sure it is square in accordance with illustration 1. Make sure the ends of the belt are square and laced properly in accordance with illustration 2.

Step 2: Run the conveyor for enough revolutions to indicate what direction it tracks.

Example: If the belt tracks to the right, adjust the right side non driven end adjusting rod (for double ended drives pick one end to adjust only) by following these steps:

Step 2a: Loosen the two (2) 5/8" drive locking nuts.

Step 2b: Turn the adjusting rod so as to move the right side non-driven end out until the belt is tracking straight.

Step 2c: Retighten the locking nuts.

Step 2d: If the above procedure does not correct the problem apply the same steps on the right side driven end.

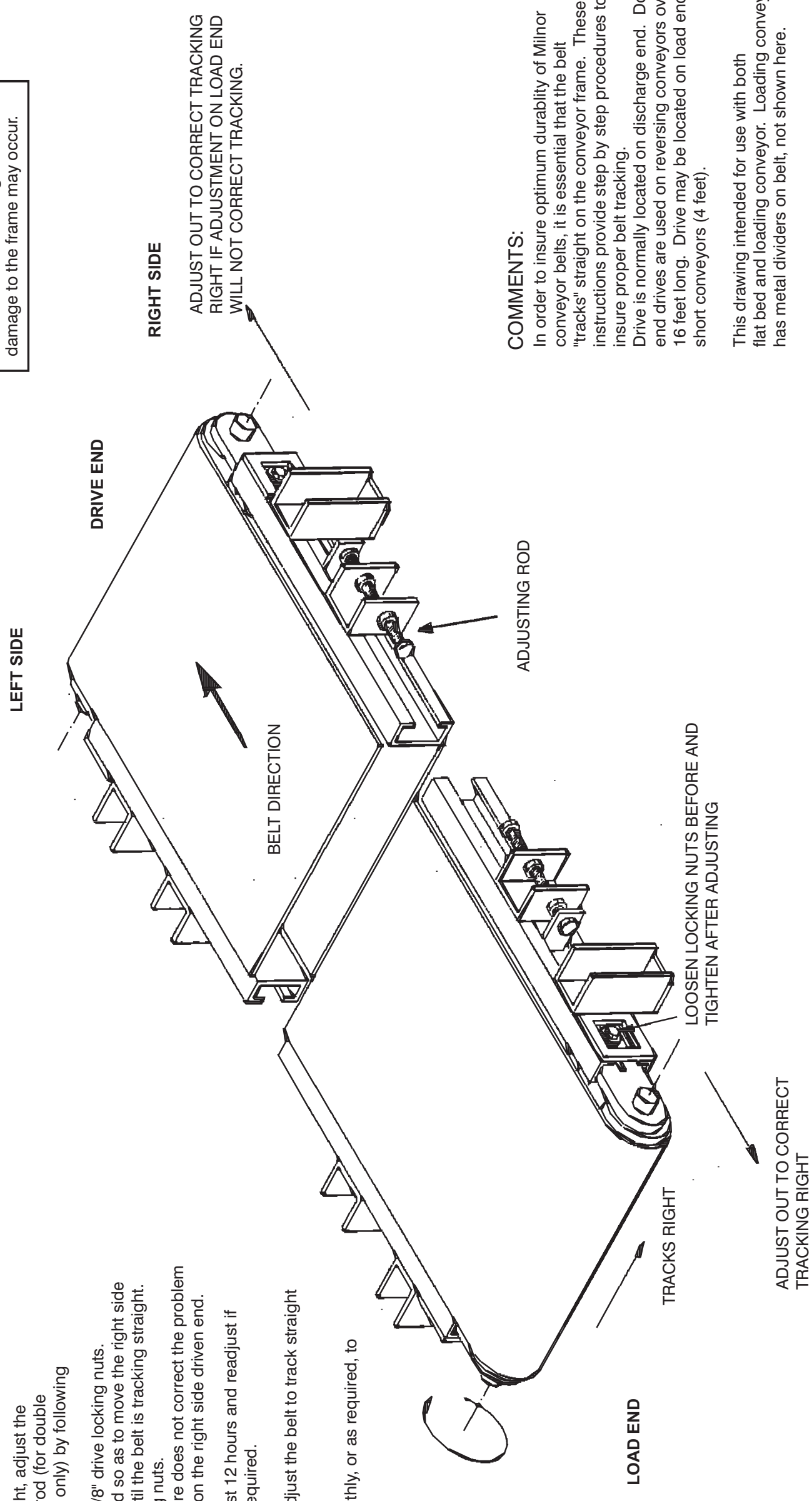
Step 3: Run the conveyor for at least 12 hours and readjust if necessary. Frequent inspection is required.

Step 4: After 72 hours operating, adjust the belt to track straight if required.

Step 5: Check the belt at least monthly, or as required, to insure straight tracking.

WARNING:

When moving conveyor, never allow frame to twist; such as would occur if one corner were raised higher than the others. Misalignment and damage to the frame may occur.



COMMENTS:

In order to insure optimum durability of Milnor conveyor belts, it is essential that the belt "tracks" straight on the conveyor frame. These instructions provide step by step procedures to insure proper belt tracking.
Drive is normally located on discharge end. Double end drives are used on reversing conveyors over 16 feet long. Drive may be located on load end of short conveyors (4 feet).

This drawing intended for use with both flat bed and loading conveyor. Loading conveyor has metal dividers on belt, not shown here.

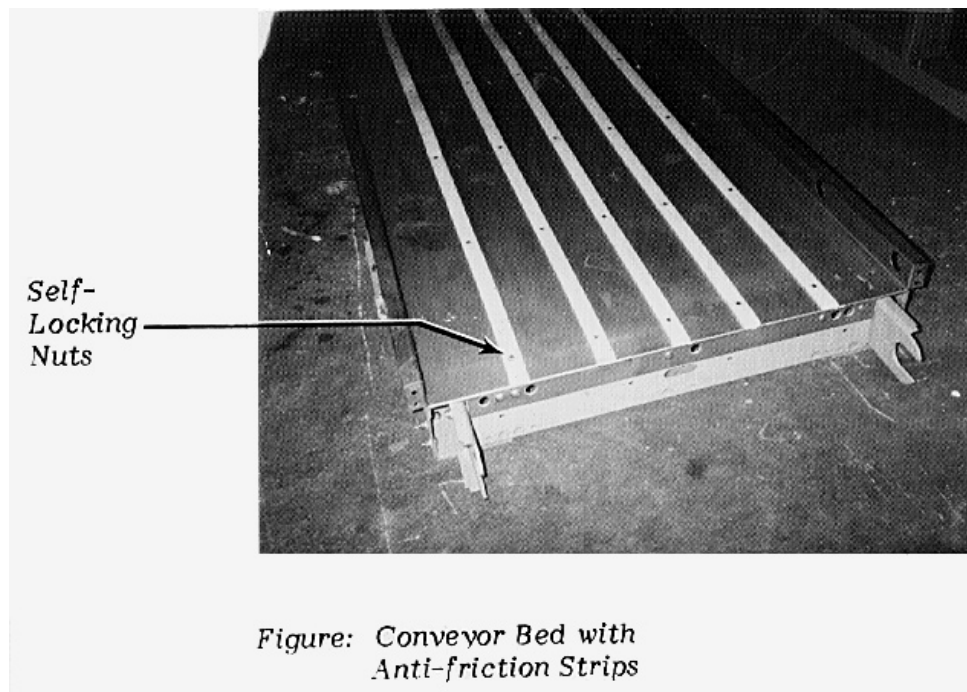
INSTALLING ANTI-FRICTION STRIPS

APPLICABILITY: Flatbed conveyors

SCOPE: Purpose for; how to install strips

The polymer anti-friction strips shipped with your conveyor must be installed after the conveyor sections have been joined together. These strips which run continuous along the entire conveyor length, prevent the conveyor belt from adhering to the bed and straining the motor when the conveyor is started.

Once all conveyor sections have been joined and before installing the belt, attach these strips as shown in the figure below using the flat head bolts and self locking nuts provided. Note that the holes in both the strips and the conveyor bed were pre-drilled.



INCLINED STORAGE CONVEYOR ASSEMBLY INSTRUCTIONS

APPLICABILITY: Inclined Storage Conveyor

SCOPE: How to assemble

NOTE: Storage conveyors are generally shipped fully assembled or in various stages of assembly depending on special site conditions.

General

It is recommended to assemble inclined COSTO conveyors in the following sequence:

1. Join beds.
2. Install plastic anti-friction strips.
3. Install adjustment leg mounts.
4. Install belt to conveyor bed.
5. Install load end legs.
6. Install unloading end legs.
7. Install middle legs.
8. Install cross members.
9. Anchor bolt legs to floor where applicable.
10. Mount motor to gear reducer where applicable.
11. Make electrical connection and extend safety shut-off switch wires.

Installation Procedure

Joining Beds

Each conveyor bed is comprised of one or more 4, 7, or 9 foot section.

The connection between bed sections is made by eight 3/8" carriage bolts at each corner of the middle section or junction of two beds. (Combination: nut, bolt, lockwasher, and flatwasher.) Six on the side and two underneath.

When bolting sections together make sure all butting surfaces are flush and the conveyor is level along the entire length. Refer to BMP820024 for flat bed conveyor assembly details.

Install Plastic Anti-Friction Strips

The polymer anti-friction strips shipped with your conveyor must be installed after the conveyor sections have been joined together. These strips which run continuously along the entire conveyor length, prevent the conveyor belt from adhering to the bed and straining the motor when the conveyor is started.

Attach anti-friction strips as shown in the figure next page using the flat head bolts and self-locking nuts supplied. Note that the strips and conveyor bed were pre-drilled. Bolt heads must be countersunk slightly below the top surface of the strip to assure that bolt head doesn't cut into belt material.

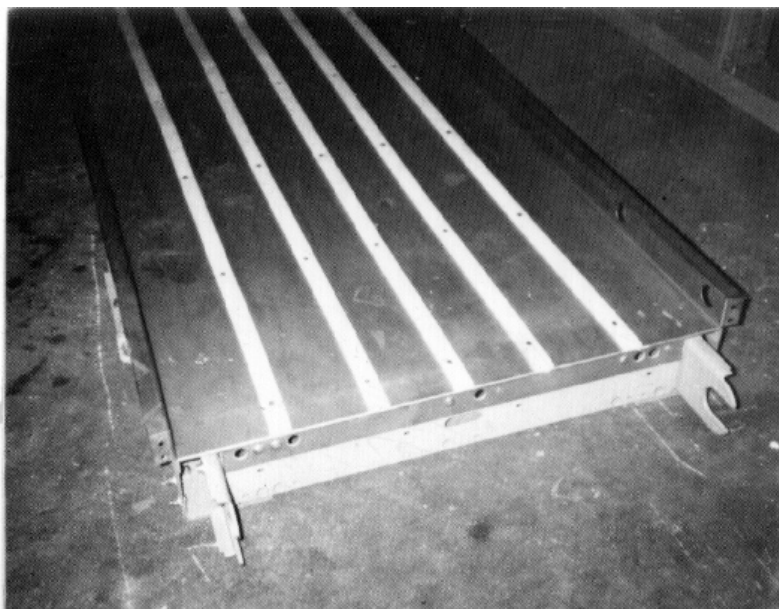


FIGURE 1: Install Anti-Friction Strips

Install Adjustment Leg Mounts

In order to raise conveyor from resting on floor, it is recommended to mount the adjustment leg mounts to the sides of the conveyor. Adjustment leg mount locations are marked with tags or illustrated by a shop sketch for positioning. Mounts are bolted to the conveyor bed in four places, as shown in the photo right, and figure next page.

Note: All bolts for attaching leg adjustment mounts, legs, and cross members are 1/2". All nuts have full threads and are used in a combination of bolt, lock-washer, and nut. Flatwashers are added where slotted holes are being used.

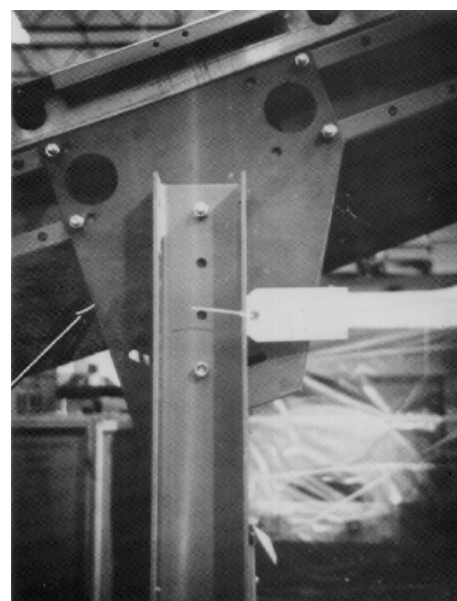
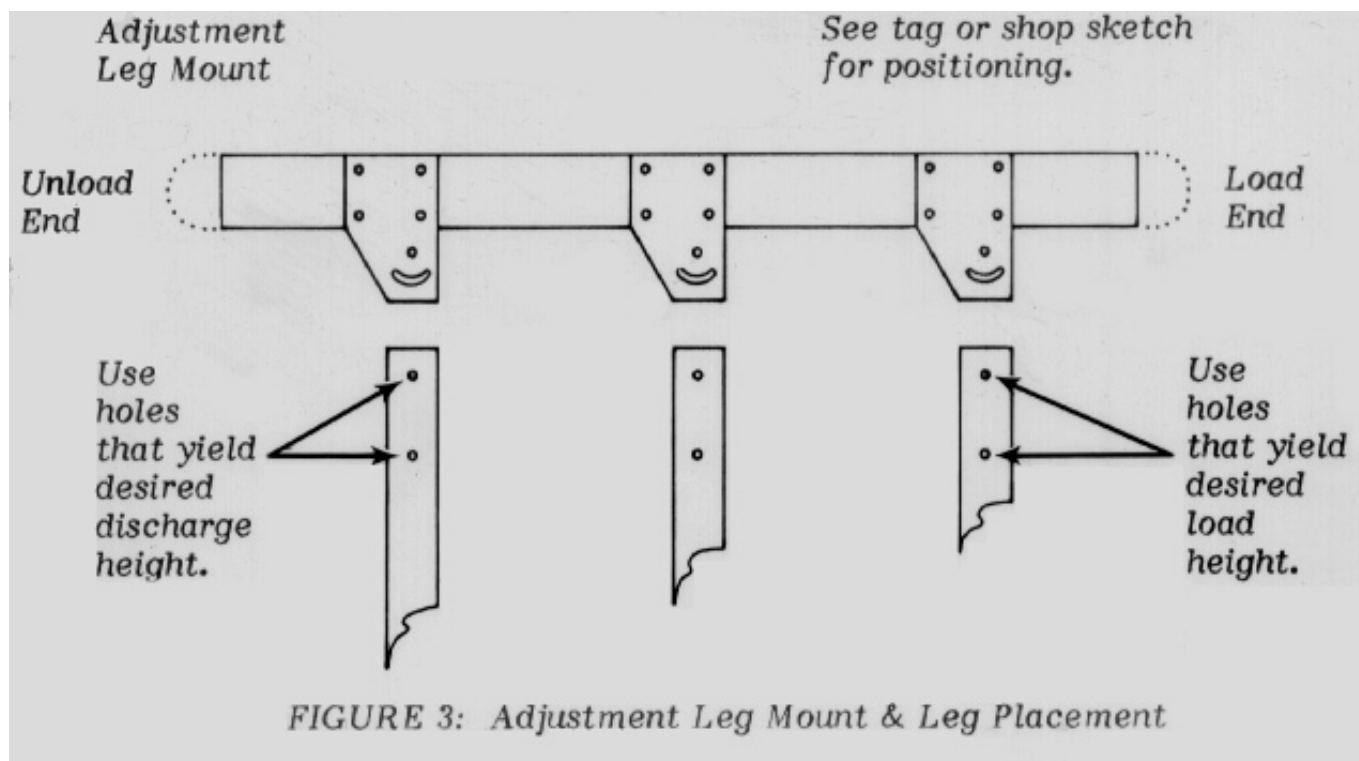


FIGURE 2: Adjustment Leg Mount



Install Belt

Belt tension adjustments are made on the idler (load) end. The bearing carrier is attached loosely to adjust tension after belt is on. See BMP820024 for more information.

Install Load End Legs

Raise load end of conveyor to load height. Position legs on adjustment leg mounts (see illustration above) and secure loosely.

Install Unloading End Legs

Raise unloading end of conveyor to discharge height and secure legs to adjustment leg mounts.

CAUTION: Do not lift conveyor from roller. This may damage the roller or belt. Lift from connecting bracket or conveyor bed. See BMP820024.

Install Middle Legs

Install middle legs to adjustment leg mount and secure. Go back and adjust all legs vertically and tighten all bolts.

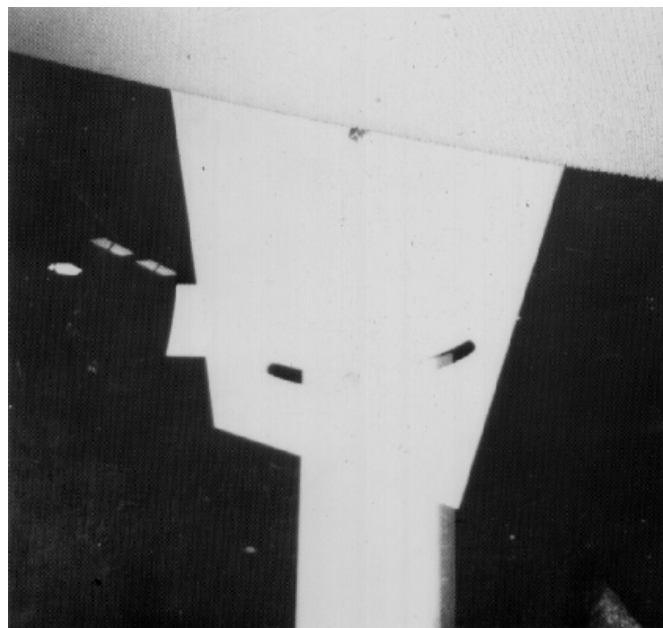


FIGURE 4: Backview Leg Connection

Install Crossmembers

Cross members are used in pairs, bracing legs front and back. Shorter legs ranging from 9" to 26" do not require crossmembers, whereas legs ranging from 27" to 145" require cross-bracing approximately 13" from the bottom of the leg using pre-drilled holes. Taller legs, ranging from 40" to 145" require a second pair of cross braces placed near the top of the legs where bolt holes are available. (See photo right.)

Anchor to Foundation

Use one 1" 0 anchor bolt per leg. Anchor bolt hardware not supplied by Pellerin Milnor Corporation.

Mount Motors

All conveyors are shipped with gear reducers mounted to the drive roller (unloading end). Motors may need to be mounted to the gear reducer if shipped detached.

Note: No adjustment is needed on the drive end of the system.

Additional Connections

Make electrical connection and extend safety shut-off switch wires.



FIGURE 5: Crossmembers, one of two shown.

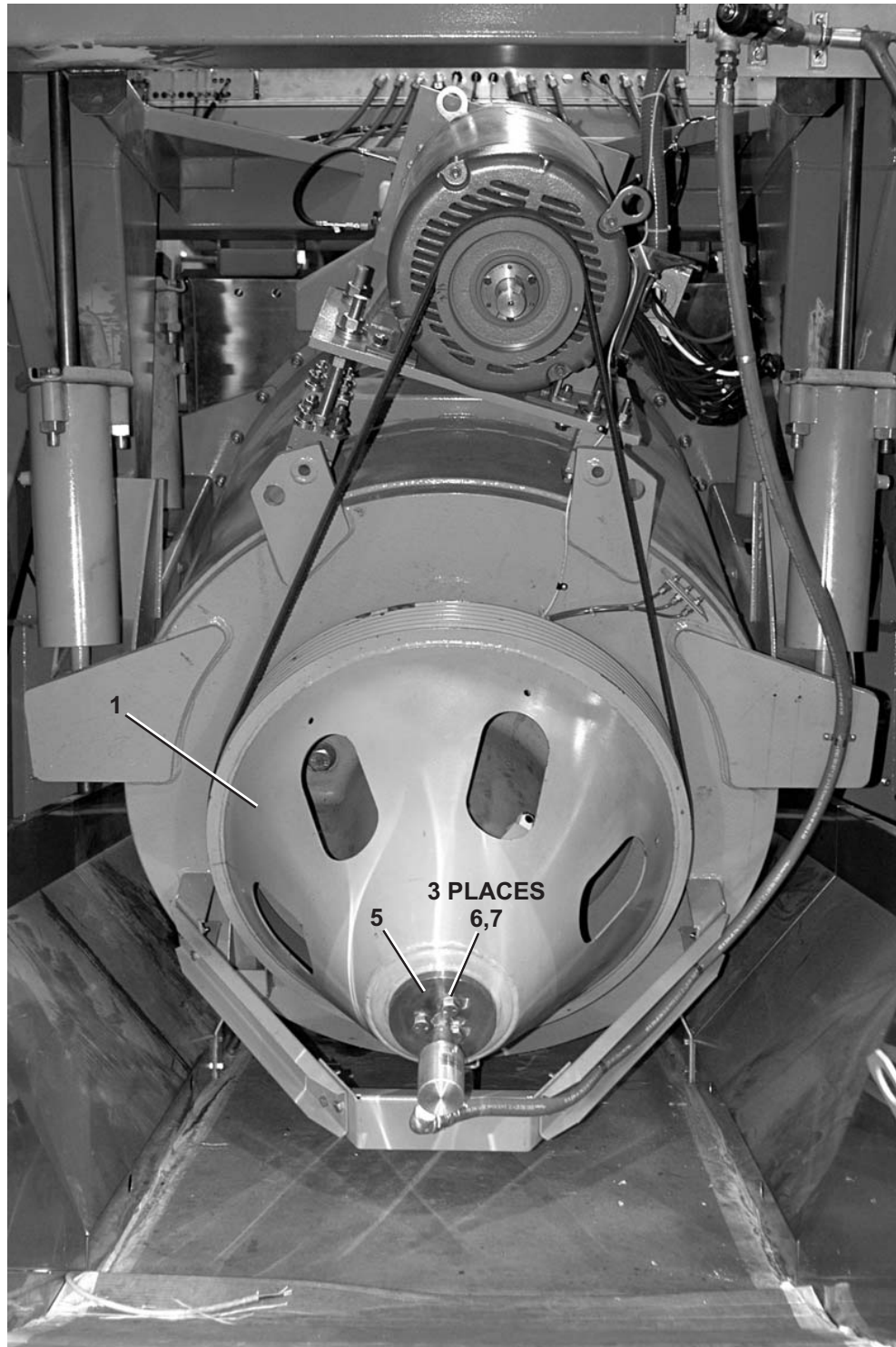
2

Drive Assemblies

2.1

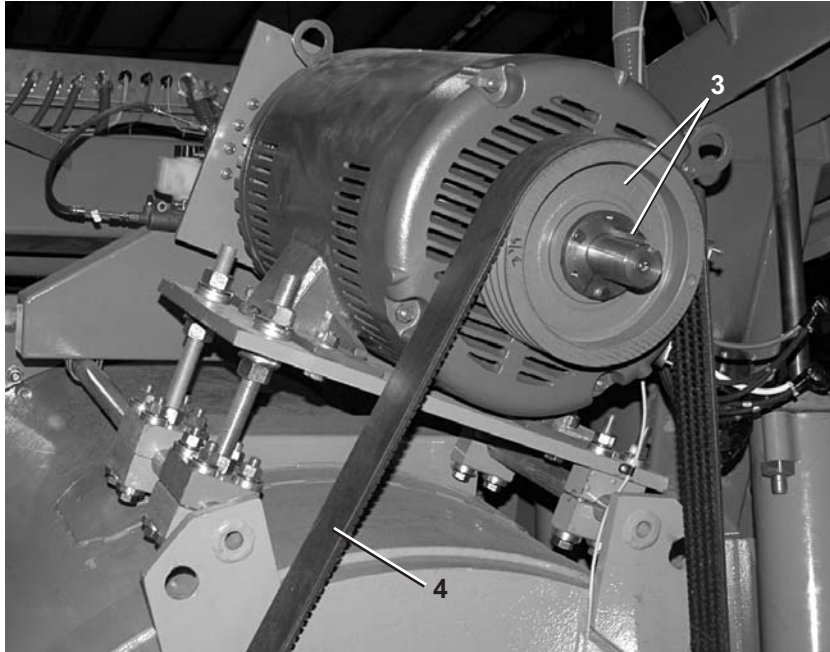
Drive Chart

M9T4840C, M9T4836C



Drive Chart

M9T4840C, M9T4836C



Parts List

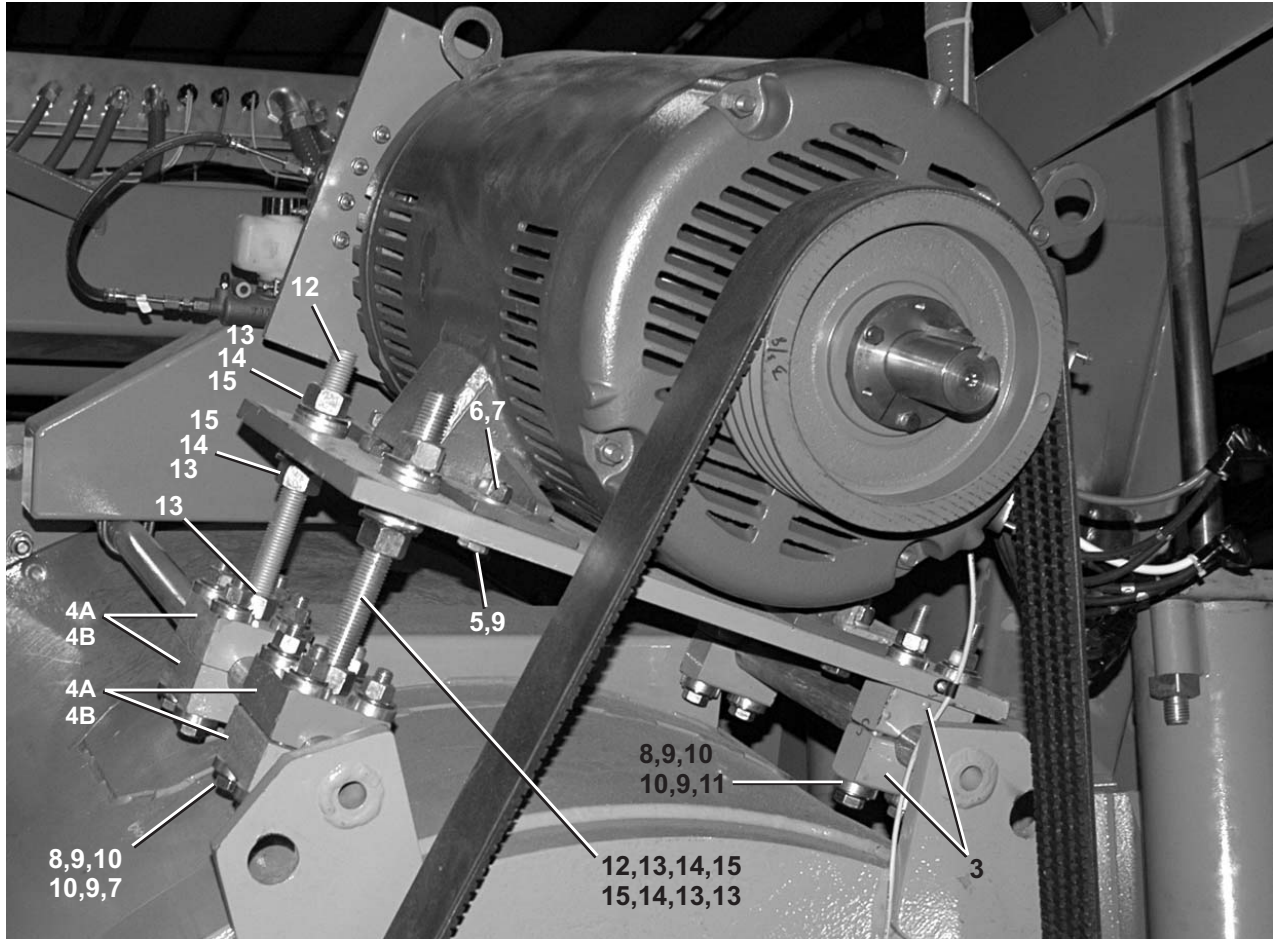
Find the correct assembly first, then find the needed components. The item letters (A, B, C, etc.) assigned to assemblies are referred to in the "Used In" column to identify which components belong to an assembly. The item numbers (1, 2, 3, etc.) assigned to components relate the parts list to the illustration.

Used In	Item	Part Number	Description	Comments
-----ASSEMBLIES-----				
		GDB4840M	INST=4840M DRIVE BASE	REFERENCE
-----COMPONENTS-----				
all	1	X2 04428	MACH=PULLEY, FAB, 4840M	
all	3	56094B6SF	VPUL 6B9.4/A9.0 (SF) TYPE QD	
all	4	56VB158XB6	VBAND 6RBX158 - 6 RIB BAND COG	
all	5	X2 21923	PLATE=PULLEY PULL UP, 4840F	
all	6	15U321H	FLTWASH 3/4 HARD ASTM F436	
all	7	15K232A	HXCPSC 3/4-10X2 GR8 ZC	

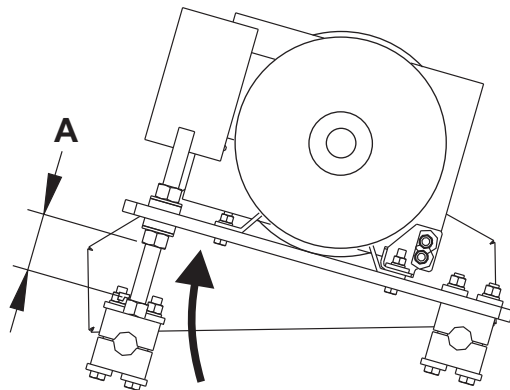
Drive Motor Installation

M9T4840C, M9T4836C

Figure 1: Rear View



Adjust the bolts to put the necessary tension on the belts.



Legend

- A. The necessary dimension for a new belt.
(M9T4840_) = 3"(76)

Drive Motor Installation

M9T4840C, M9T4836C

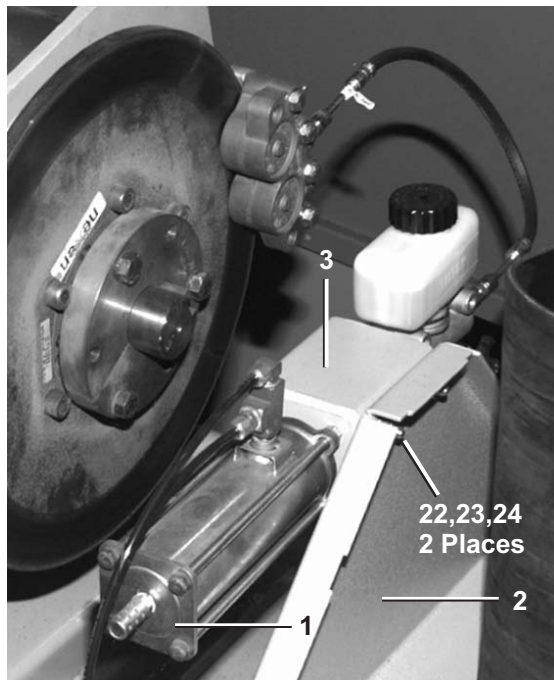
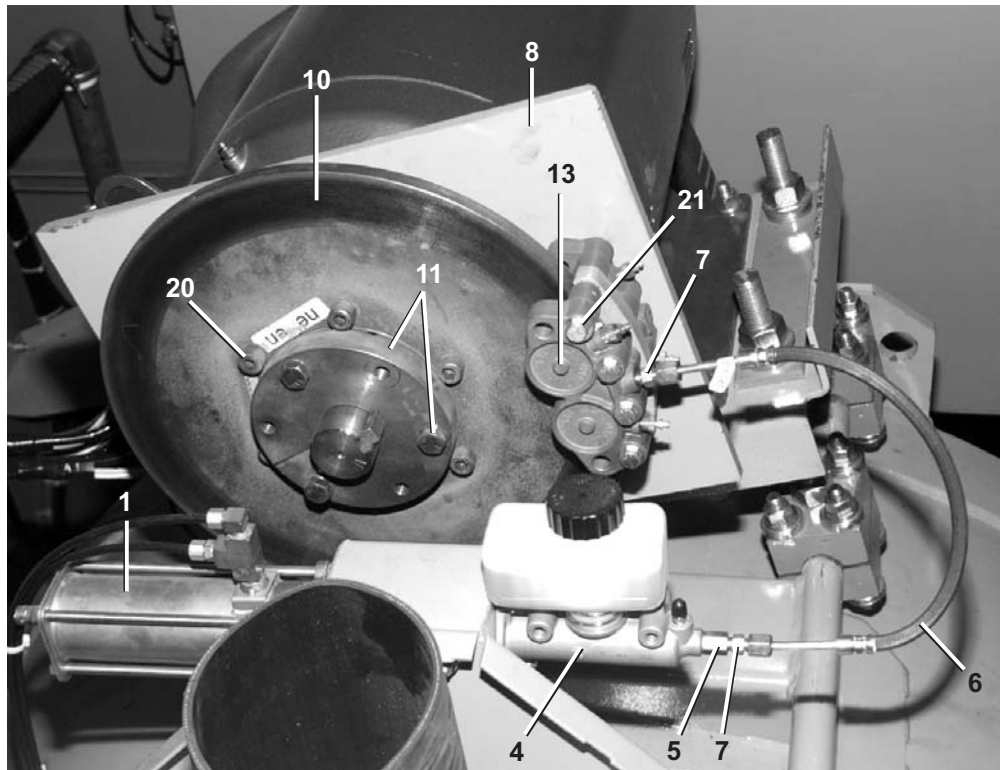
Parts List

Find the correct assembly first, then find the needed components. The item letters (A, B, C, etc.) assigned to assemblies are referred to in the "Used In" column to identify which components belong to an assembly. The item numbers (1, 2, 3, etc.) assigned to components relate the parts list to the illustration.

Used In	Item	Part Number	Description	Comments
			-----ASSEMBLIES-----	
	A	GDB4840M	INST=4840M DRIVE BASE	
			-----COMPONENTS-----	
all	1	03 17130	4840M EXTRACTOR MOTOR PLATE	
all	2	W3 17142	BRAKE TEFC MOTOR TORQARM-4840M	
all	3	02 11311B	MTR BASE PIVOT CLAMP	
all	4	X2 11311P	PAINT=JACKBOLT CLAMP, 6836F	
all	4	C2 11311C	CAST=JACKBOLT CLAMP, 6836F	
all	5	15K225A	HEXCAPSCR 5/8-11X2.5 GR9 ZINC	
all	6	15U315	LOKWASHER MEDIUM 5/8 ZINCPL	
all	7	15G238	HXNUT 5/8-11UNC2B SAE ZINC GR2	
all	8	15K227D	HEXCAPSCR 5/8-11X6 GR8 ZINC	
all	9	15U316	FLTWASH 5/8 HARD ASTM F436	
all	10	17W030	SPHERICAL WASHER SET 5/8 M/F	
all	12	15K227B	HEXCAPSC 5/8-11X5.5 GR8 ZINC	
all	13	17R031A13A	THRD ROD 1-8 X 13" GR8 ZNPL	
all	14	15G250	HXNUT 1-8UNC2B SAE ZNC GR2	
all	15	15U393	FLTWASH 1" HARD ASTM F436	
all	16	17W060	SPHERICALWASHER SET 1" M/F	
all	17	15K226L	HEXCAPSCW 5/8-11X3.5 GR8 ZINC	

Disc Brake

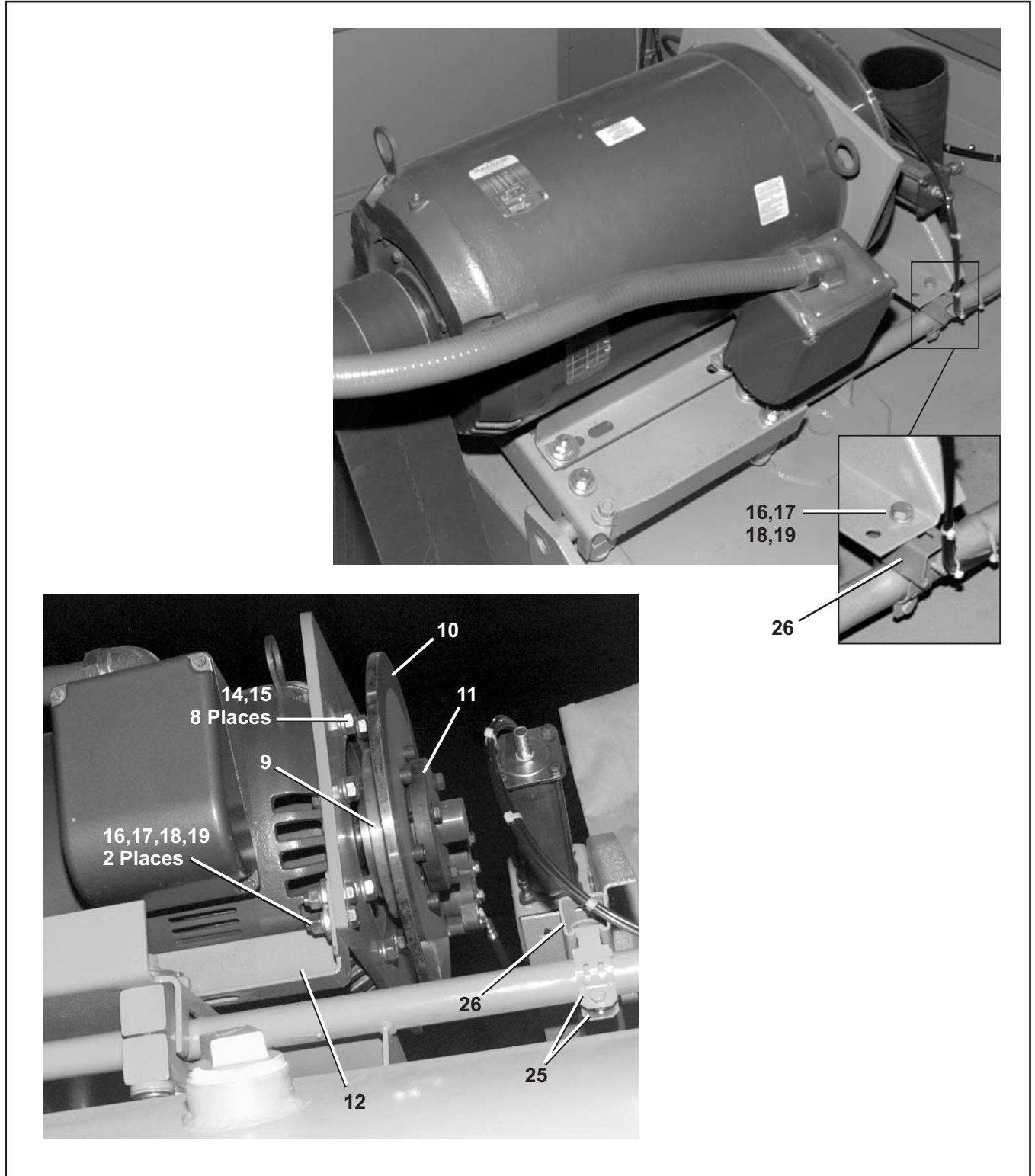
M9T4840C, M9T4836C



(This brake assembly is shown is on 6836F5N, but also applies to M9T4840C & M9T4836C .)

Disc Brake

M9T4840C, M9T4836C



Disc Brake

M9T4840C, M9T4836C

Parts List

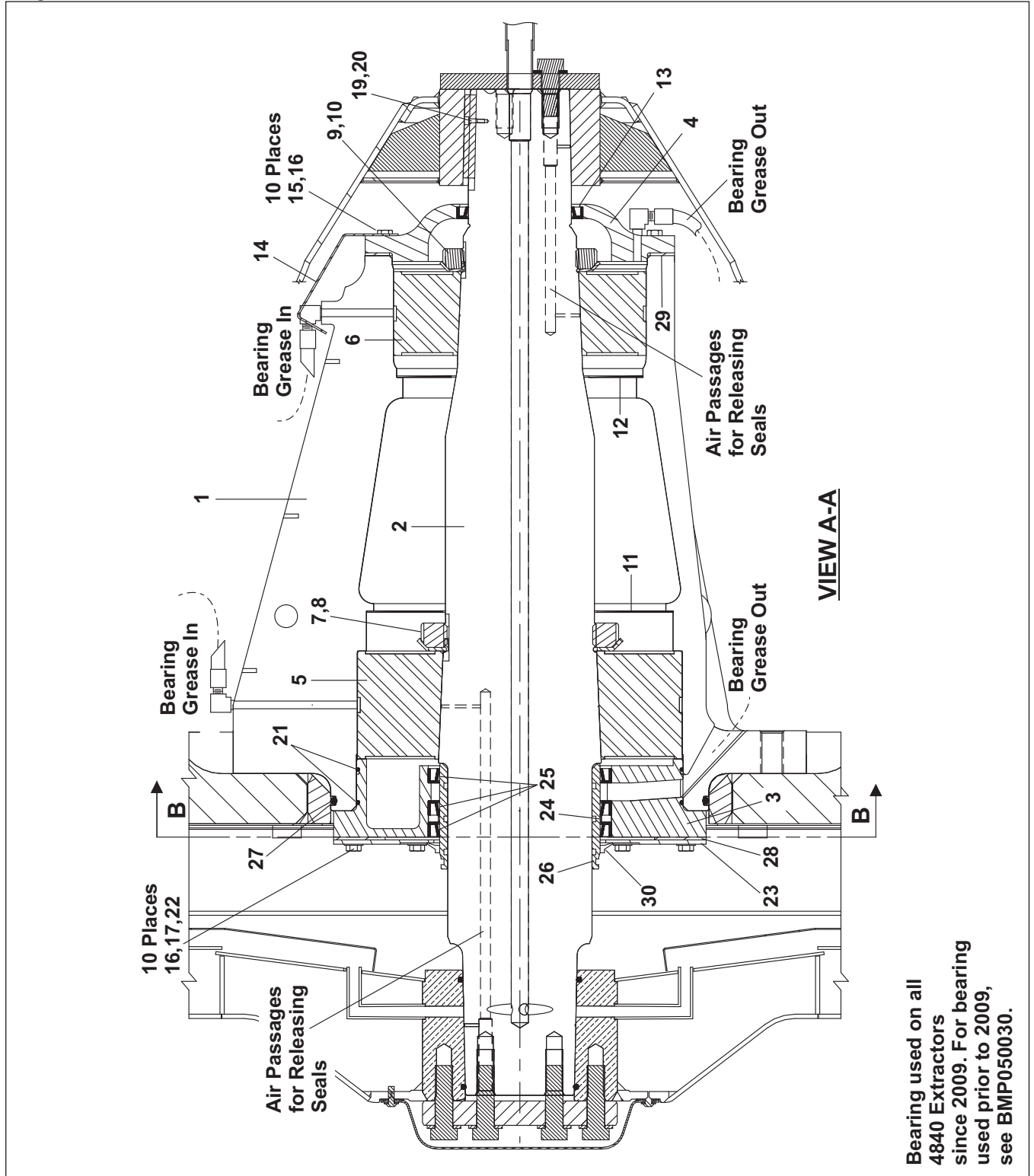
Find the correct assembly first, then find the needed components. The item letters (A, B, C, etc.) assigned to assemblies are referred to in the "Used In" column to identify which components belong to an assembly. The item numbers (1, 2, 3, etc.) assigned to components relate the parts list to the illustration.

Used In	Item	Part Number	Description	Comments
			-----ASSEMBLIES-----	
	A	GBR6836E	INST=DISC BRAKE 6836E	
			-----COMPONENTS-----	
all	1	AAC4840F	AIRCYL=BRAKE ASSY, 4840F7	
all	2	02 22417	48M7 BRAKE+PROX MNT BRKT	
all	3	W3 65238	*WLMT=MASTER BRAKE CYL BRKT	
all	4	54KMC1125U	MASTER CYL = WILWOOD	
all	5	52XY0ER004	STRADTUN3/16MJX1/8FP#2405-3-2	
all	6	54KC7961BG	BRAKE HOSE=1/8"X18" (FEMXFEM)	
all	7	52AY0ER003	STR.1/4"MJICX1/8"MP#2404-4-2	
all	8	X2 04454	MACH=BRK CALPR MNT PLT,6836	
all	9	X2 04458	BRAKE ROTOR HUB-6836E	
all	10	X2 04459	BRAKE ROTOR-6836E	
all	11	56Q1RE	1+7/8" BUSH VPUL QD TYPE E	
all	12	W3 17142	BRAKE TEFC MOTOR TORQARM-4840M	
all	13	54KC7975	CALIPER HYD D/A 1/2" RETRACT.	
all	14	15K214E	HXCAPSCR 5/8-11UNC2AX1.5 GR5 Z	
all	15	15U315	LOKWASHER MEDIUM 5/8 ZINCPL	
all	16	15K151	HXCAPSCR 1/2-13UNC2AX1.25 GR5	
all	17	15U490	FLTWASH 1+1/2X17/32X1/4 ZINC	
all	18	15U300	LOKWASHER REGULAR 1/2 ZINC PLT	
all	19	15G230	HXNUT 1/2-13UNC2B SAE ZINC GR2	
all	20	15K155A	SKCPSCR-1/2-13X1.5	
all	21	15K086G	HEXCAPSCR 3/8-24UNF X5" GRD. 8	
all	22	15K095	HXCPSR 3/8-16UNC2AX1 GR5 ZINC	
all	23	15U255	LOCKWASHER MEDIUM 3/8 ZINCPL	
all	24	15G205	HXNUT 3/8-16UNC2B ZINC GR2	
all	25	27A0075	CLP-RGDSTL PS#1100-3/4	

Bearing Assembly

M9T4840C, M9T4836C

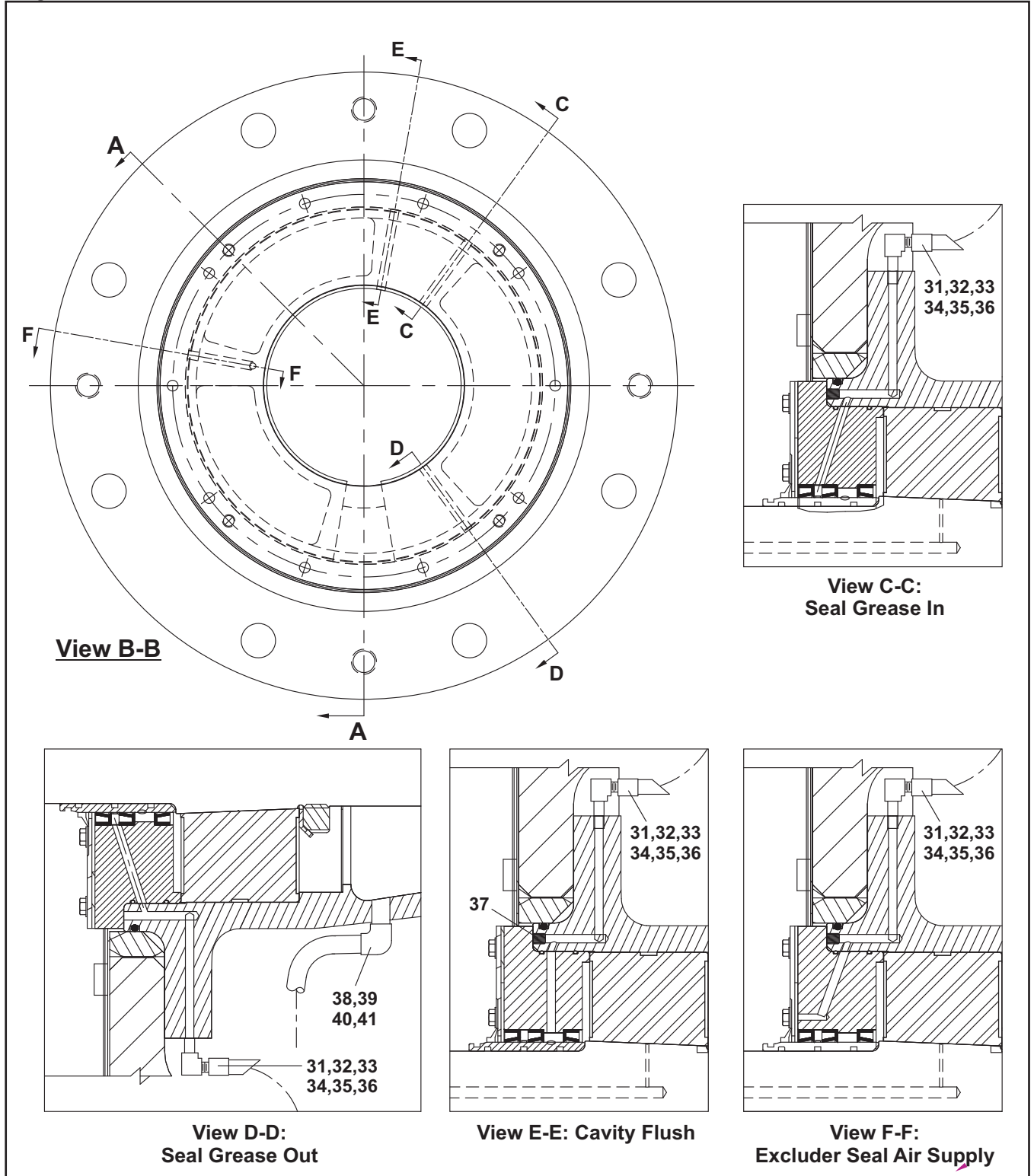
Figure 1: View A-A



Bearing Assembly

M9T4840C, M9T4836C

Figure 2: Detail Views



Bearing Assembly

M9T4840C, M9T4836C

Parts List				
Find the correct assembly first, then find the needed components. The item letters (A, B, C, etc.) assigned to assemblies are referred to in the "Used In" column to identify which components belong to an assembly. The item numbers (1, 2, 3, etc.) assigned to components relate the parts list to the illustration.				
Used In	Item	Part Number	Description	Comments
-----ASSEMBLIES-----				
	A	GBM4840M	INST=MAIN BRG HSE, 4840M	REFERENCE
	B	ABM4840M7A	ASSY=BRN HOUSE, STD, 4840M	REFERENCE
	C	ABN4840M7A	ASSY=ABM-HSE&SHFT,STD, 4840M7A	REFERENCE
-----COMPONENTS-----				
all	1	X3 17184	MACH=BEARING HOUSING, 4840M	
all	2	X3 17186	MACH=MAIN SHAFT,48M	
all	3	X3 17185	MACH=FRONT SEAL HOLDER, 4840M	
all	4	X2 04395	MACH=REAR SEAL HOLDER, 6836E	
all	5	56S22334C4	SPHROLGRG SKF#22334 CCK/C4W33	
all	6	56S22326C3	SPHROLGRG SKF #22326 CCK/C3W33	
all	7	56AHW34	W34 BEARING LOCKWASHER	
all	8	56AHN34	AN34 BEARING LOCKNUT	
all	9	56AHW26	W26 BEARING LOCKWASHER	
all	10	56AHN26	AN26 BEARING LOCKNUT	
all	11	02 04393	FRONT GREASE SHIELD, 6836E	
all	12	02 04394	REAR GREASE SHIELD, 6836E	
all	13	24S114	SEAL 4.5X5.5X.50 JM# 9170 LUP	
all	14	02 04456	PULLEY PHOTOEYE BRKT, 6836E	
all	15	15K151	HXCAPSCR 1/2-13UNC2AX1.25 GR5	
all	16	20C007G	THDLOCKSEAL LCT24231 RMUBL50CC	
all	17	15U240L9	FTWASH 3/8 HARD ASTM F436	
all	18	54M029	RELIEFFIT 1/8STR ALEMITE 47200	
all	19	X2 21816	MACH=PULLEY KEY, 4840F	
all	20	15N091	PANHDMACHSCR 8/32UNC2X1/2 S/S	
all	21	60C280	ORING 14.0ID 1/8CS BN70-280	
all	22	15K122	HEXCAPSCR 3/8-16UNCX2 SS18-8	
all	23	03 17189	PLATE=EXCLUDER SEAL, 4840M7	
all	24	24S130LR	LANTERN RING=7X8X.313	
all	25	24S130	SEAL 7.0X8.0X.625 JM#6862 NITR	
all	26	X3 17187	SLEEVE=GREASE SEAL PRESSFIT	
all	27	60C461	ORING 16.0ID 1/4CS BN70-461	
all	28	03 17183	GASKET=EXCLUDER SEAL, 4840M7	
all	29	03 17190	GASKET=REAR SEAL, 4840M7	
all	30	24S146	SEAL 7.0X8.0X.437 TYPE SSW NIT	
all	31	5SB0E0CBEO	NPTHEXBUSH 1/4X1/8 BRASS 125#	

Bearing Assembly

M9T4840C, M9T4836C

Parts List

Find the correct assembly first, then find the needed components. The item letters (A, B, C, etc.) assigned to assemblies are referred to in the "Used In" column to identify which components belong to an assembly. The item numbers (1, 2, 3, etc.) assigned to components relate the parts list to the illustration.

Used In	Item	Part Number	Description	Comments
all	32	53A501	TUBE INSERT .163"OD #63PT-4-40	
all	33	53A500	SLEEVE DELRIN 1/4"OD#60PT-4	
all	34	53A059A	NUT 1/4"BR.HOLYOKE AND #61A-4	
all	35	60E004TC	TUBING NYL(NAT)1/4"ODX.17ID	
all	36	53A031B	BODY-EL90MALE.25X1/8 #269C-42B	
all	37	5SP0CBEHS	NPT PLUG 1/8 HXCTRSNK BRASS	
all	38	51E510	HOSESTEM BRASS 1/2MPX3/4HOSEID	
all	39	5N0KCLSG42	NPT NIP 1/2XCLS TBE GALSTLSK40	
all	40	5SL0KMFA	NPT ELBOW 90DEG 1/2" BLKMAL 15	
all	41	60E008A	TUBINGNYLREINF.75"IDX1.025"OD	

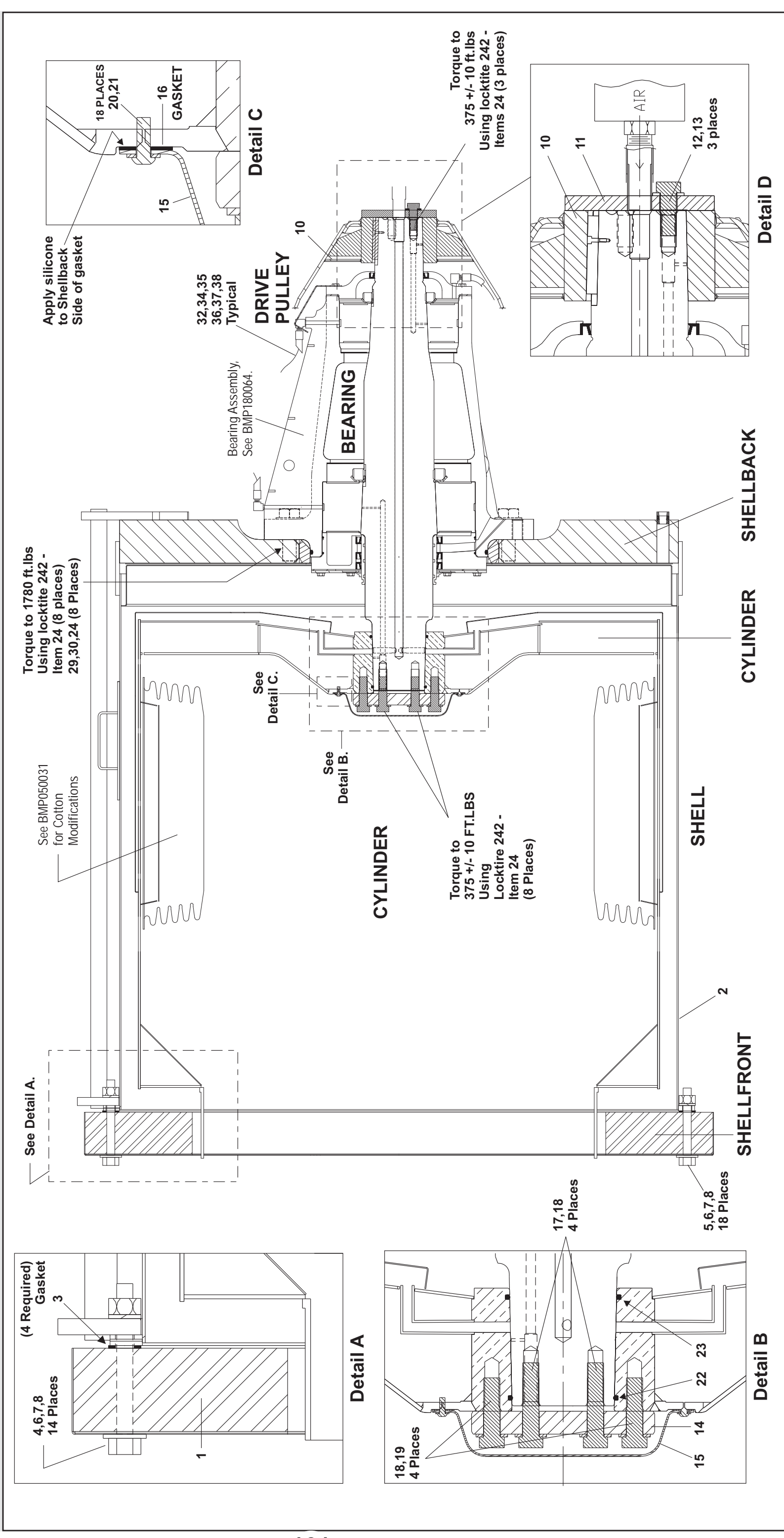
Shell, Cylinder, Bearing, & Pulley Installation

BMP180061/2018444B
(Sheet 1 of 2)



Pellerin Milnor Corporation
P. O. Box 400, Kenner, LA 70063-0400

Litho in U.S.A.



Shell, Cylinder, Bearing, & Pulley Installation

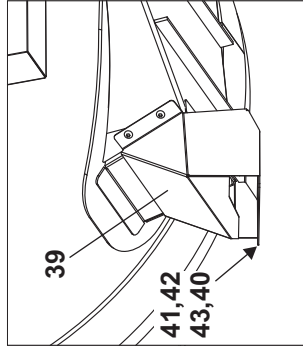
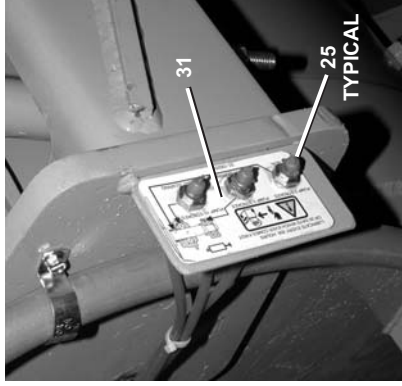
M9T4840C, M9T4836C

BMP180061/2018444B
(Sheet 2 of 2)

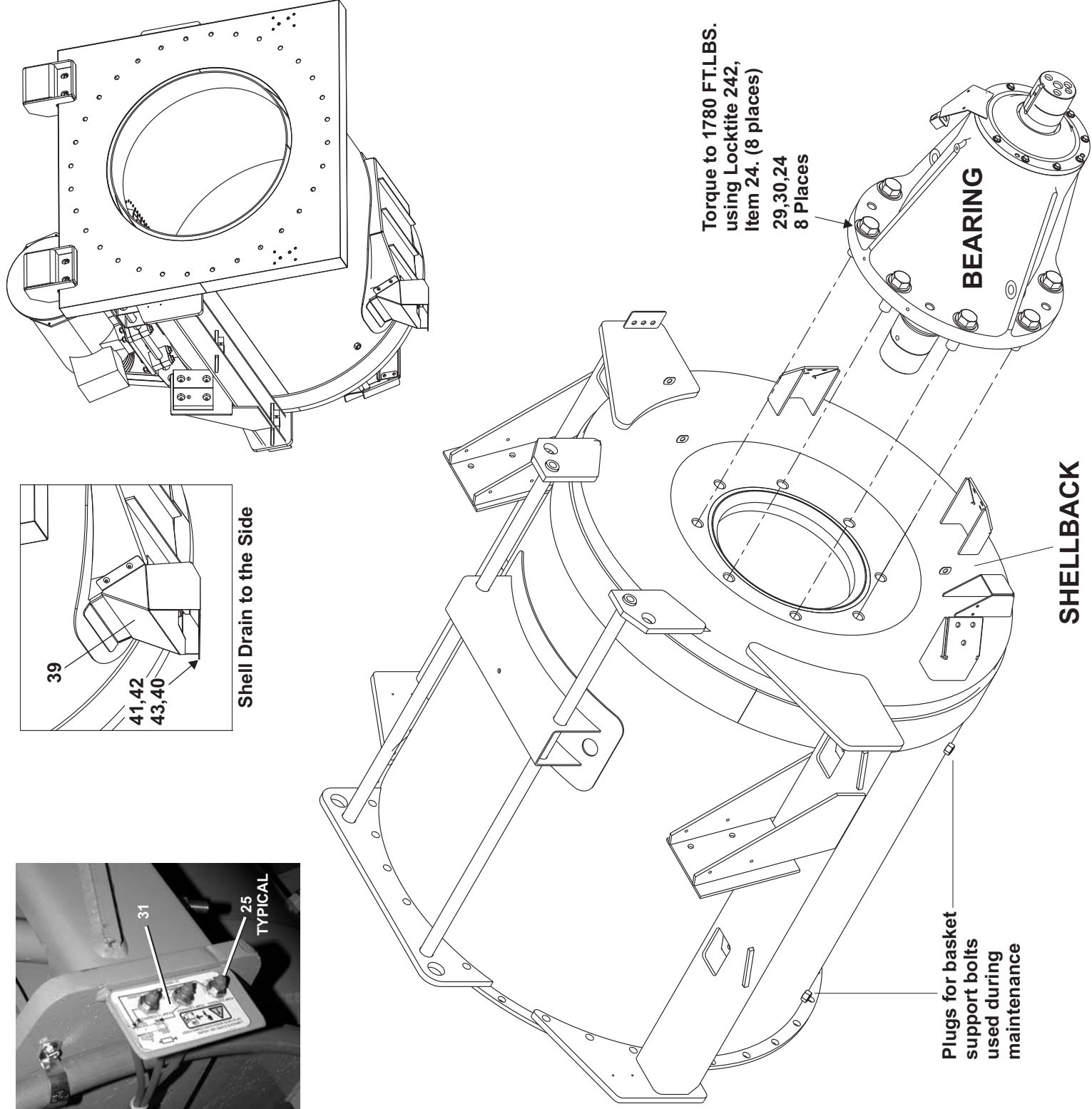


Pellerin Milnor Corporation
P. O. Box 400, Kenner, LA 70063-0400

Litho in U.S.A.



Shell Drain to the Side



Parts List—Shell, Cylinder, Bearing & Pulley
Find the correct assembly first, then find the needed components. The item letters (A, B, C, etc.) assigned to assemblies are referred to in the "Used In" column to identify which components belong to an assembly. The item numbers (1, 2, 3, etc.) assigned to components relate the parts list to the illustration.

Used In	Item	Part Number	Description	Comments
A		ASE17002	SHELL ASSEMBLY=M9T4840	REFERENCE
B		GBM4840M	INST=MAIN BRG HSE, 4840M	REFERENCE
C		ABM4840M7A	ASSY=BRN HOUSE, STD, 4840M	REFERENCE
D		GCA17002	CYL INSTL=4840M COTTON	REFERENCE
-----ASSEMBLIES-----				
	1	W3 17002	WLMT=4840 SHELLFRONT W/CLAD	
	2	W3 17020C	WLMT=7GA SHELL 4840M SIDE DRAIN	
	3	03 48053B	GSKT=53+1/2BC 4840F 1/8 THK	
	4	15K235GS	HEXCAPSCR 3/4-10X7SS #70377	
	5	15K235ES	HEXCAPSCR 3/4"-10X6 SS #70375	
	6	15U331	FLTWASHER 3/4X1+3/4 SS #71027	
	7	15U350	LOCKWASHER 3/4 MED SS18-8	
	8	15G244A	HEXNUT 3/4-10UNC2B BRASS	
	9	15U494	3/4SAE CLPFW.812IDX1.5ODX.135T	
	10	X2 04428	MACH=PULLEY, FAB, 4840M	
	11	X2 21923	PLATE=PULLEY PULL UP, 4840F	
	12	15K232A	HEXCAPSCR 3/4-10X2 GR8 ZINC	
	13	15U321H	FLTWASH 3/4 HARD ASTM F436	
	14	X2 21916	CYL PULL-UP PLATE, 4840F7	
	15	X2 21917	COVER=CYL HUB, 4840F7 MACH	
	16	02 21918	GASKET= CYL HUB COVER, 4840F7	
	17	15K240D	HEXCAPSCR 3/4-16X3 GR8 ZINC	
	18	15U321H	FLTWASH 3/4 HARD ASTM F436	
	19	15K234CA	HEXHDSR 3/4-10X2.25 GR8 ZINC	
	20	15U188	FLTWASH 1/4 STD COMM SS18-8	
	21	15K040T	1/4-20X3/4 TAMPTORXBUTHDNIP SS	
	22	60C155V	ORING 4.75ID3/16CS VITON75#351	
	23	60C157V	ORING 4+7/8ID 3/16CS VITON-352	
	24	20C007G	THDLOCKSEAL LCT24231 RMUJBL50CC	
	25	54M021	GRSFT 1/8PIPE X 1/4STR 1607-B	
	26	60E008A	TUBINGNYLREINF.75"IDX1.025"OD	
	27	27A044S	HOSECLAMP 11/16-1.25SSCR#64012	
	28	27A030B	UBOLT 3/4PIPE 1/4-20 THD ZINC	
	29	15K309	HEXCAPSCR 1.25-7UNC X 4.0 ZINC	
	30	15U600	FLTWASH 1+1/4 HARD ASTM F436	
	31	01 10025X	NPLT:BEARING+SEAL LUB - ISO	
	32	60E004TC	TUBING NYL(NAT)1/4"ODX.17ID	
	33	5SB0E0CBEO	NPTHEXBUSH 1/4X1/8 BRASS 125#	
	34	53A501	TUBE INSERT .163"OD #63PT-4-40	
	35	53A500	SLEEVE DELRIN 1/4"OD#60PT-4	
	36	53A059A	NUT 1/4"BR.HOLYOKE AND #61A-4	
	37	53A031B	BODY-EL90MALE.25X1/8 #269C-42B	
	38	53A007B	BODYFEMCON.25X.25COMP#B66A-4B	
	39	W3 17147	SHELL SIDE DRAIN WLMT-4840M	
	40	03 17149	4840M DRAIN OUTLET EXTENSION	
	41	15K033	BUTSOKCAPSCR 1/4-20X5/8 SS18-8	
	42	15U188	FLTWASH 1/4 STD COMM SS18-8	
	43	15G164NE	HEXLOKNUT NYL 1/4-20 UNC2A SS.	

Cylinders and Cotton Mod Piping

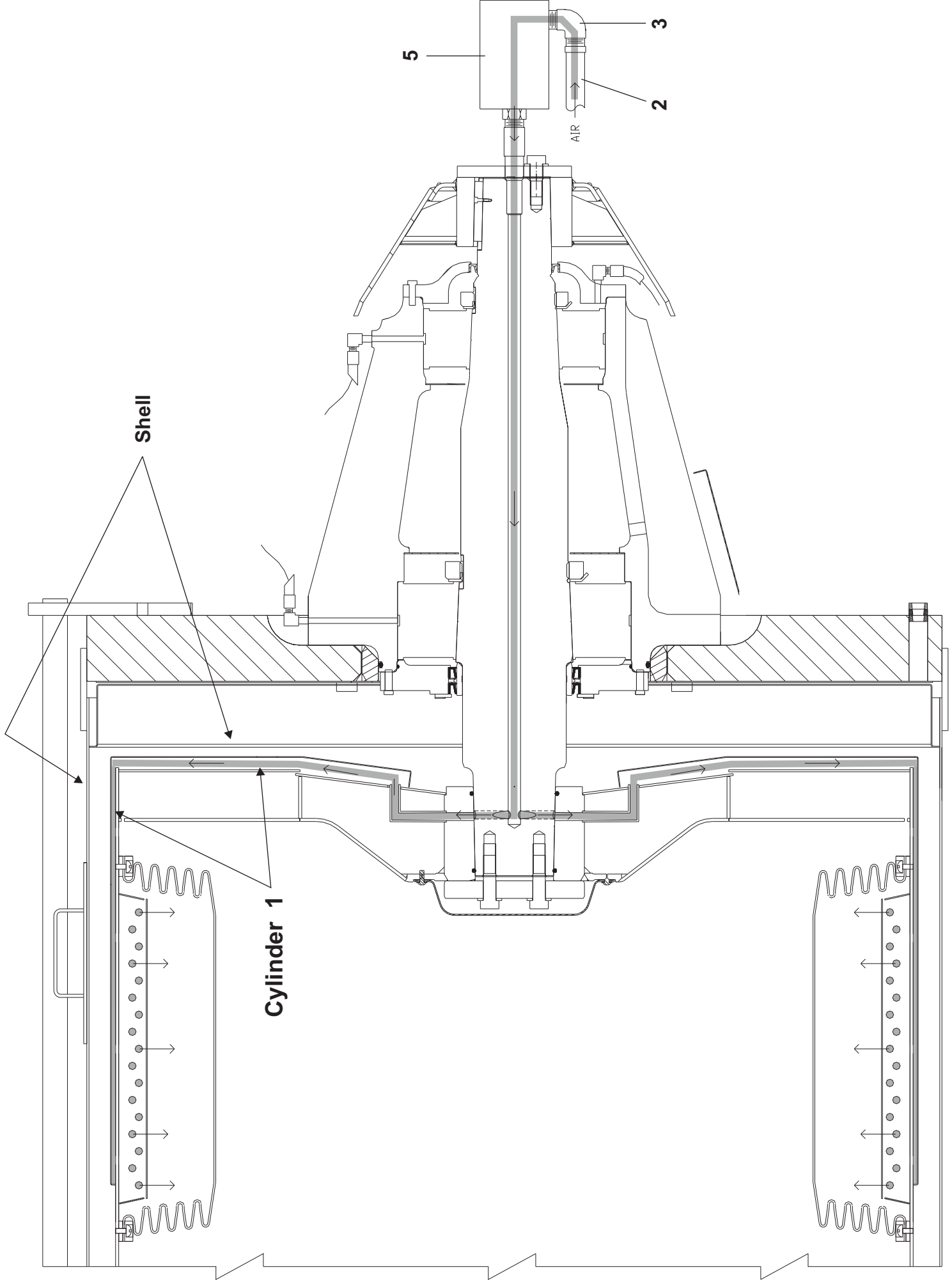
M9V4232C/L/R, MXV4232C/L/R, MMV4232C/L/R M9S4232C/L/R, MXS4232C/L/R, MMS4232C/L/R M9V4840C/L/R

BMP050031/2022146B
(1/4)

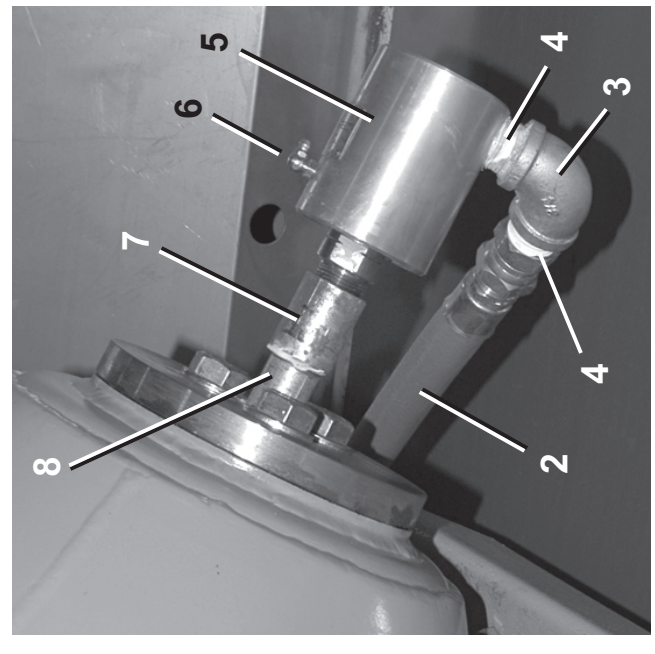


Pellerin Milnor Corporation
P. O. Box 400, Kenner, LA 70063-0400

Litho in U.S.A.



Inflatable rib assembly (See BMP110048.)



Air through bearing to cylinder ribs

Cylinders and Cotton Mod Piping

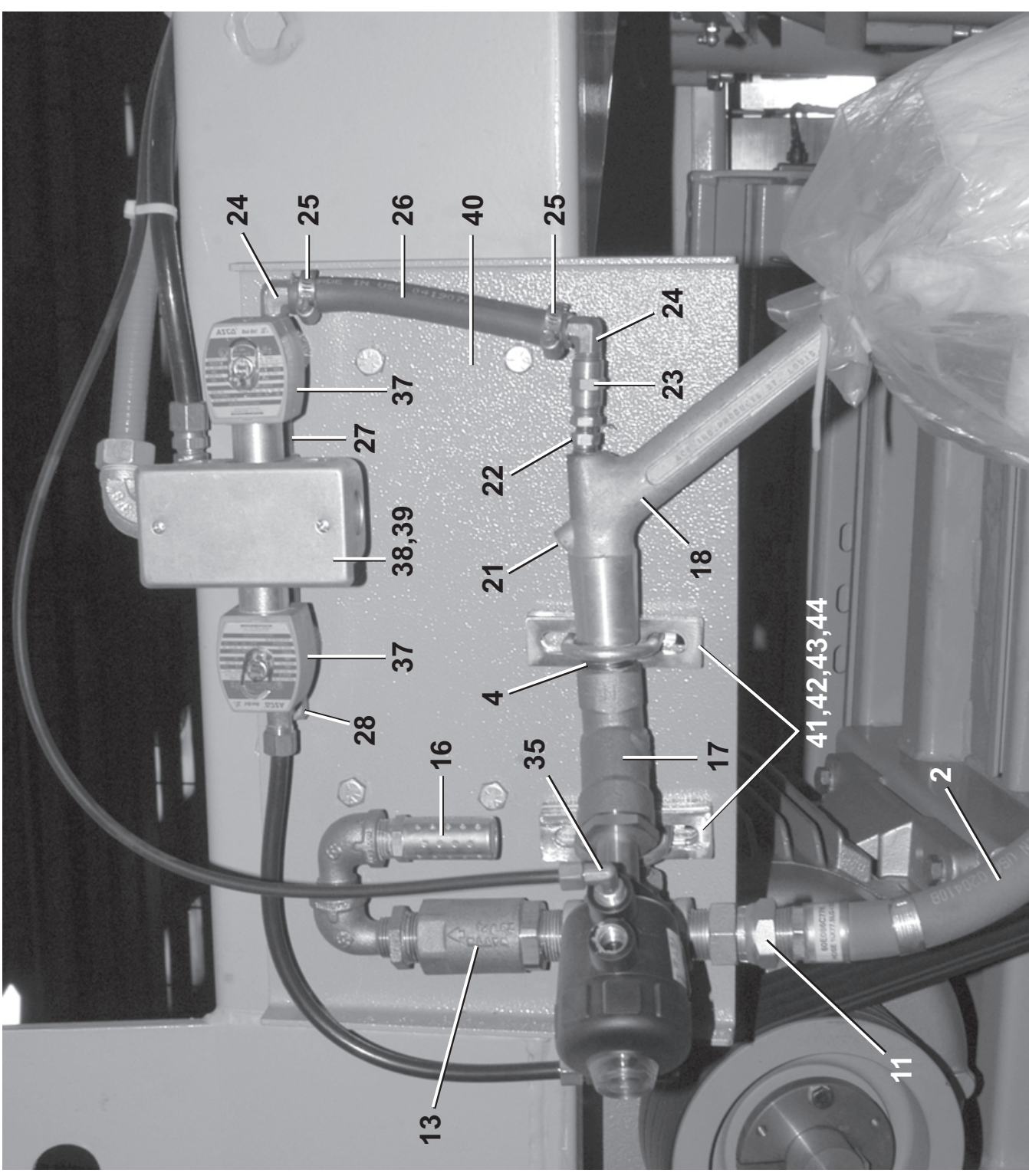
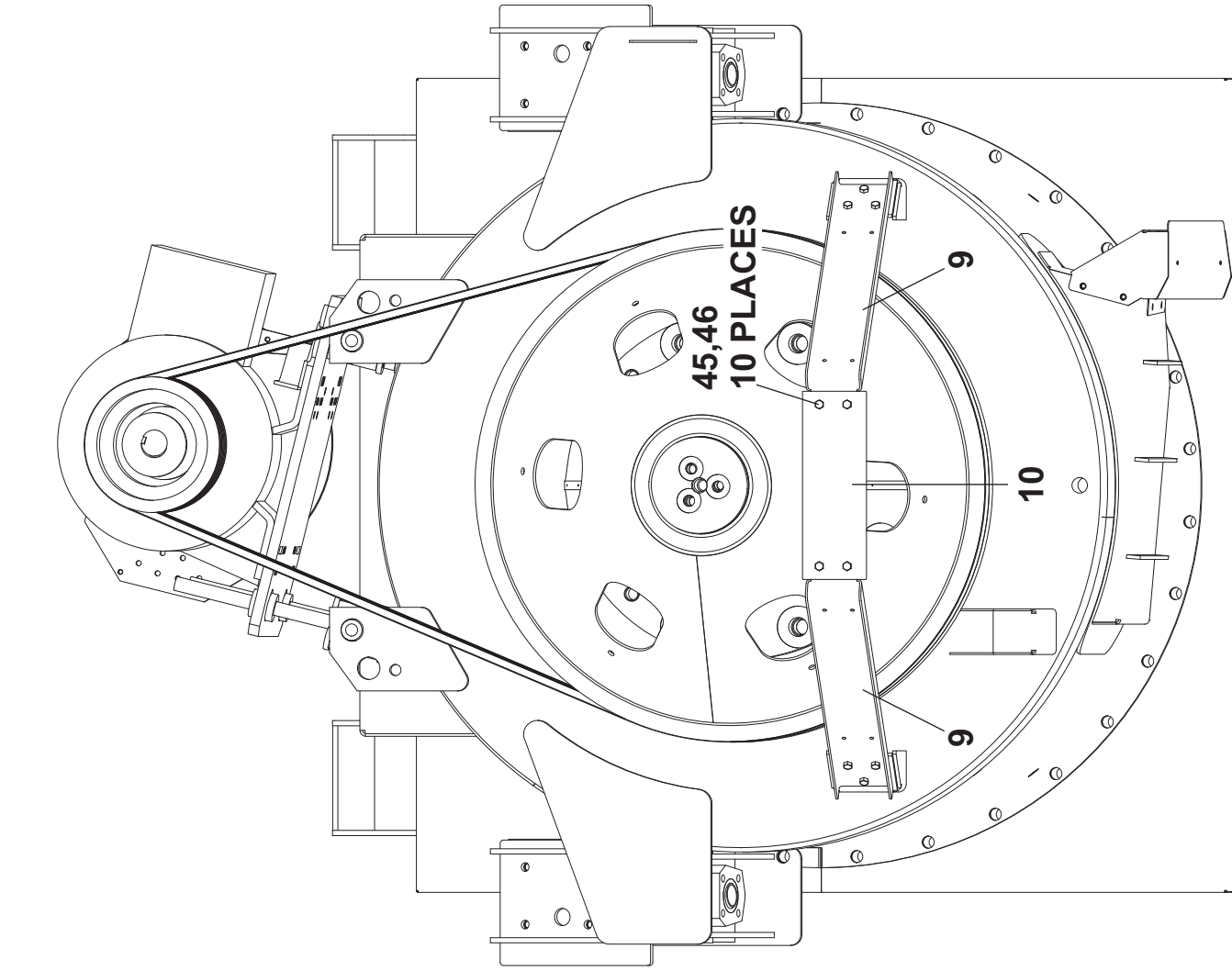
M9V4232C/L/R, MXV4232C/L/R, MMV4232C/L/R M9S4232C/L/R, MMS4232C/L/R, MXS4232C/L/R, M9V4840C/L/R

BMP050031/2022146B
(2 / 4)



Pellerin Milnor Corporation
P. O. Box 400, Kenner, LA 70063-0400

Litho in U.S.A.



Cotton Mod Piping

Cylinders and Cotton Mod Piping

M9V4232C/L/R, MXV4232C/L/R, MMV4232C/L/R M9S4232C/L/R, MXS4232C/L/R, MMS4232C/L/R M9V4840C/L/R



Pellerin Milnor Corporation
P. O. Box 400, Kenner, LA 70063-0400

M9V4840C/L/R

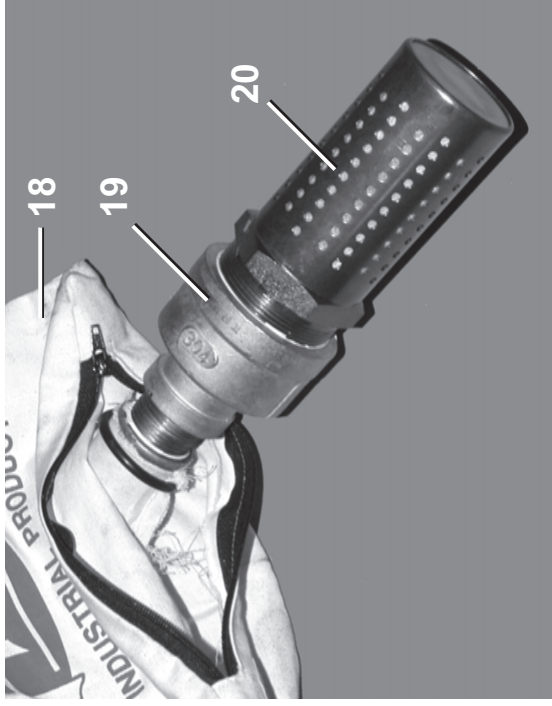
M9S4232C/L/R, MXS4232C/L/R, MMS4232C/L/R

BMP050031/2022146B
(3 / 4)

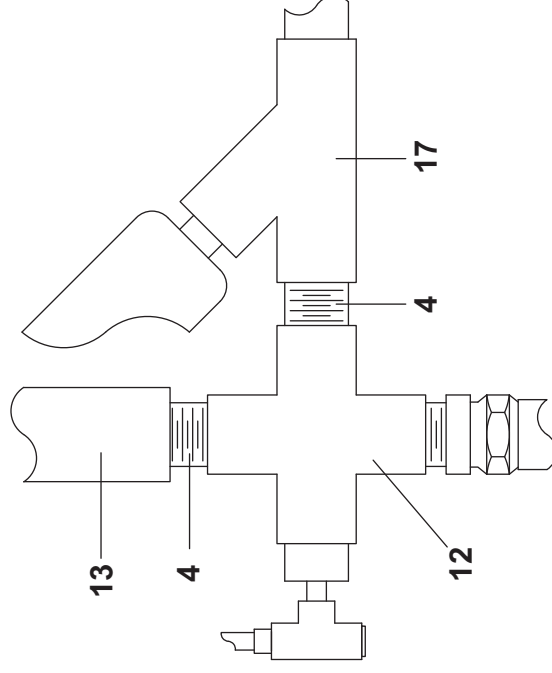
Litho in U.S.A.

Parts List—Cylinders and Cotton Mod Piping
Find the correct assembly first, then find the needed components. The item letters (A, B, C, etc.) assigned to assemblies are referred to in the "Used In" column to identify which components belong to an assembly. The item numbers (1, 2, 3, etc.) assigned to components relate the parts list to the illustration.

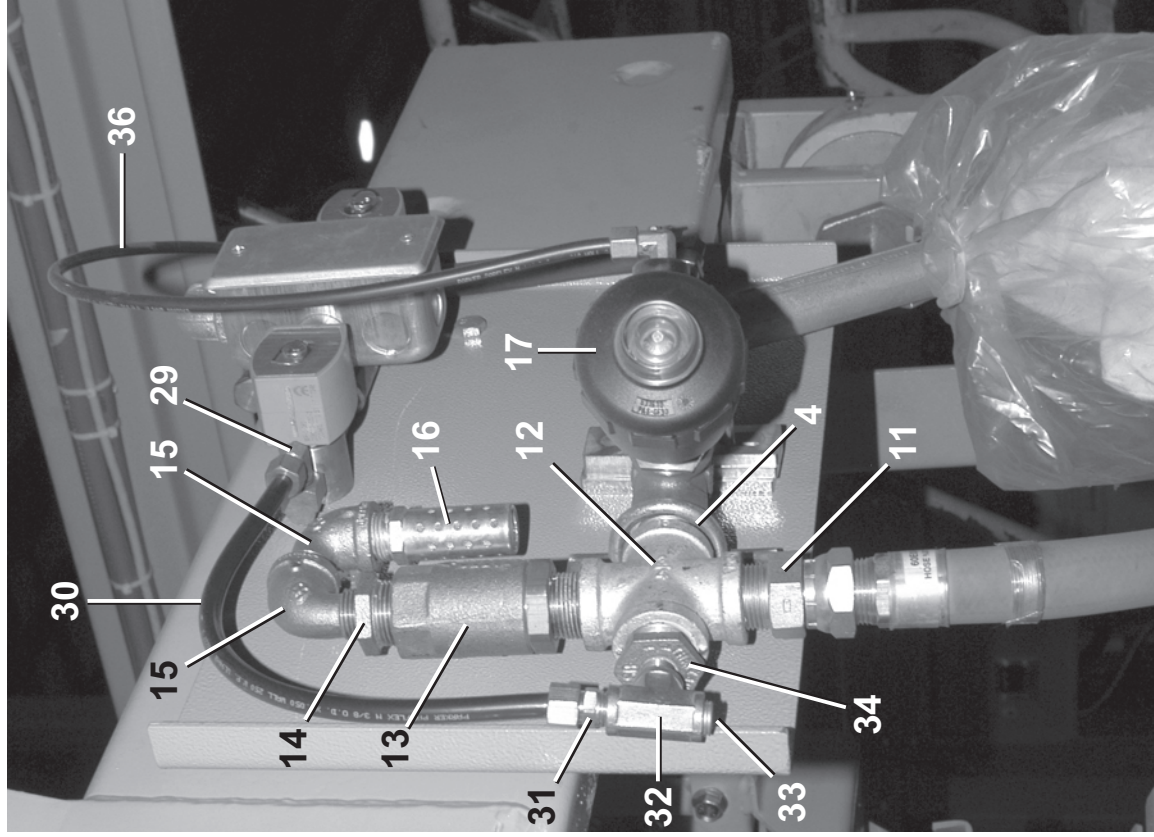
Used In	Item	Part Number	Description	Comments
			-----REFERENCE ASSEMBLIES-----	
	A	ACM16001	COTTON MOD PIPING ASSY	M9V4232, MXV4232 M9S4232, MXS4232 MMV4232, MMS4232
	B	ACM17002	CYLINDER BELT LINER ASSY-4840M	M9V4840
			-----COMPONENTS-----	
all	1	ACA42CTM9E	*7GA CYL COTTON MOD 4232M9E	M9E4232 COT CYLINDER
all	1	ACA4232C01	ASSY=7GA CYLINDER COT MOD, 4232M9/MX	M9S/MXS4232 COT CYL.
all	1	ACA42TFMXV	7GA CYL TEFLON 4232MXV COT	MXV4232 COT TEFLON
all	1	ACA42TFMMV	ASSY=CYL COT TEFLON 4232MMV	MMV4232 COT CYLINDER
all	1	ACA4232MV1	ASSY=7GA CYL TEF COT MOD, 4232MMS	MMS4232 COT TEFLON
all	1	ACA4840COT	CYL ASSY COTTON 4840M	M9V4840 COT CYLINDER
A	2	60E086C77K	WATERHOSE=.75"X77.5" LG + 2 EN	
B	2	60E086C106	HOSE ASSY=3/4"X106"LG+ENDS	
all	3	5SL0PNFA	NPT ELB 90DEG 3/4 GALMAL 150#	
all	4	5N0PCLSG42	NPT NIP 3/4XCLS TBE GALSTL S40	
all	5	24S075	ROTUNION 3/4"	
all	6	54M021	GRSFIT 1/8PIPE X 1/4STR 1607-B	
all	7	5SCC0PNF	NPT COUP 3/4 GALMAL 150#	
all	8	5N0P03AG42	NPT NIP 3/4X3 TBE GALSTL SK40	
A	9	03 17059	4840M AIR HOSE BAR	
B	10	03 17039	4840M AIR SUPPORT BRKT	
all	11	51X019	UNIONSTRADT 3/4"#0107-12-12	
all	12	5SX0PNF	NPT CROSS 3/4" GALMAL 150#	
all	13	96D046	CK VAL 3/4"W/S	
all	14	5SB0P0KBEO	NPTHEXBUSH 3/4X1/2 BRASS 125#	
all	15	5SL0KBEC	NPT ELB 90DEGSTRT 1/2 BRASS 125	
all	16	27A005B	MUFFLER 1/2"	
all	17	96D0009E	3/4"NPTBRZ N/C STEAMVAL ANGBOD	
all	18	X3 16201T	AIR VAC #80-201 TAPPED ENDS	
all	19	5SR2A1ASF	NPT RED 2X1 SS304 150#	
all	20	27A005C	MUFFLER 1"	



Vacuum and muffler



Detail: Cross tee



Cotton Mod Piping



Pellerin Milnor Corporation
P. O. Box 400, Kenner, LA 70063-0400

Litho in U.S.A.

Parts List—Cylinders and Cotton Mod Piping

Find the correct assembly first, then find the needed components. The item letters (A, B, C, etc.) assigned to assemblies are referred to in the "Used In" column to identify which components belong to an assembly. The item numbers (1, 2, 3, etc.) assigned to components relate the parts list to the illustration.

Used In	Item	Part Number	Description	Comments
all	21	51T020	STRAINER 1/4 AND.BRASS#234S-L	
all	22	5SB0E0CBEO	NPTHEXBUSH 1/4X1/8 BRASS 125#	
all	23	5SCC0EBE	NPT COUP 1/4 BRASS 150#PSI W/HEX	
all	24	51E504EB	ELB HOSESTEM 3/8HX1/4NPT BRASS	
all	25	27A040	HOSECLAMP 7/16-25/32SS W/SCREW	
all	26	6.00E+78	HOSE AIR-WATER 3/8"#7134-381	
all	27	5N0E02ABE2	NPT NIP 1/4X2TBE BRASS 125#	
all	28	5SLOEBEC	NPTLNB 90DEG STRT 1/4 BRASS125	
all	29	53A043G	EL90 3/8X1/4COMP.AND#69A-6B	
all	30	60E005B	TUBING NYL.3/8"OD X.275"ID	
all	31	53A043A	BULKHDUNION 3/8"COMP.BODY ONLY	
all	32	5S0EBEA0G	NPT TEE 1/4X1/4X3/8 BRASS 125#	
all	33	51P013	PLUG HXCNTRSUNK 1/4"BRASS	
all	34	5SB0F0EBEO	HEXBUSH 3/4X1/4 BRASS 125#	
all	35	53A031B	BODY-EL90MALE.25X1/8	
all	36	60E004TE	1/4"OD X.170"ID NYL(BLK)TUBING	
all	37	96TBC2BA37	1/4" N/C 2WAY 120V50/60C VALVE	
all	38	12H050D	HANDYBOX 4X2+1/8 X 2+1/8	
all	39	12H095	HANDY BOX COVER 4+2+1/8	
all	40	03 16353	AIR SUCT CONTROL BRKT	
all	41	27A031B	UBOLT 1"PIPE 5/16-18X3 5/8LG	
all	42	15U210	LOKWASHER MEDIUM 5/16 ZINCPL	
all	43	15G185	HXNUT 5/16-18UNC2B SAE ZINC GR	
all	44	02 10539S	SPACER PIPE DAS	
all	45	15K146	HEX CAP SCR 1/2-13 UNC2 X 1 SS	
all	46	15G225H	HEXFLGNUT 1/2-13 SERRATED 18-8	

Inflatable Rib Assembly

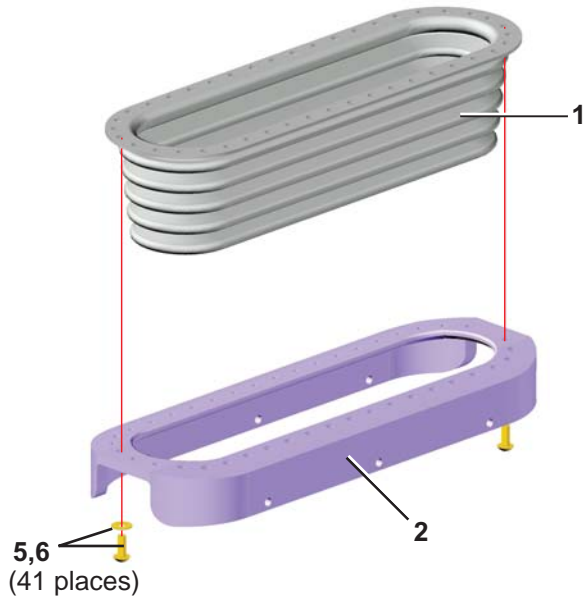
MXS4232, M9V4232, M9V4840, M9T4840

BMP110048/2019174A
(Sheet 1 of 2)



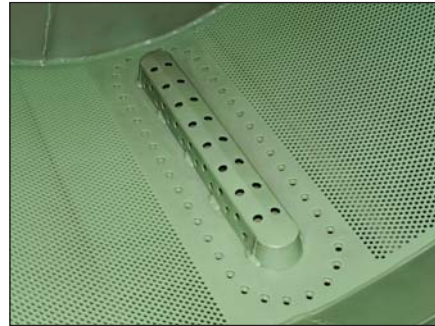
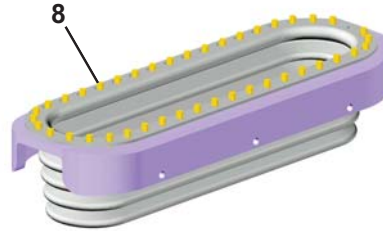
Pellerin Milnor Corporation
P. O. Box 400, Kenner, LA 70063-0400

Litho in U.S.A.

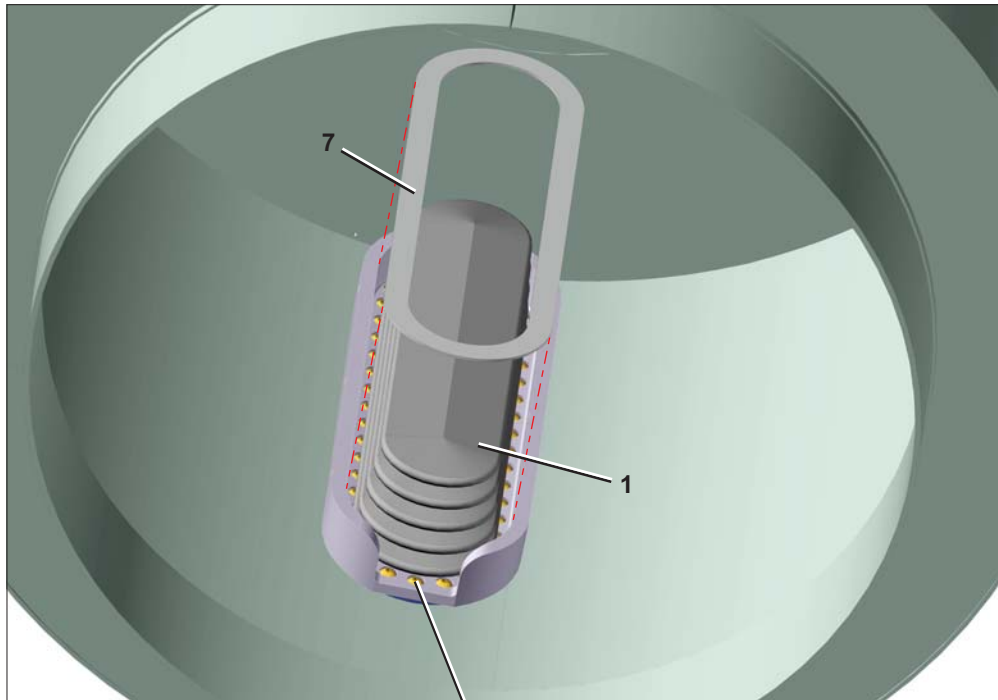


Pre-assemble the inflatable ribs, uhmw trays, and the gaskets (2 assemblies). Insert all 82 bolts (item 5).

Apply thread locker, item 8, to the ends of the bolts.



Cylinder with Cotton Modifications



Install the inflatable rib assemblies to the cylinder. Tighten the bolts to 10 ft-lbs of torque. Cover the bolts with EPDM gasket (item 7) and position it under the inflatable rib (item 1).

Inflatable Rib Assembly

MXS4232, M9V4232, M9V4840, M9T4840

BMP110048/2019174A
(Sheet 2 of 2)



Pellerin Milnor Corporation
P. O. Box 400, Kenner, LA 70063-0400

Litho in U.S.A.

Parts List—Inflatable Rib Assembly

Find the correct assembly first, then find the needed components. The item letters (A, B, C, etc.) assigned to assemblies are referred to in the "Used In" column to identify which components belong to an assembly. The item numbers (1, 2, 3, etc.) assigned to components relate the parts list to the illustration.

Used In	Item	Part Number	Description	Comments
-----ASSEMBLIES-----				
	A	KQM-E00202	M7E 42EXT=INFLAT RIBS .165THK	AVAILABLE KIT INCLUDES ALL PARTS LISTED BELOW, ALL 4232 & 4840 EXTRACTORS
-----COMPONENTS-----				
all	1	03 16014E	EXTRACTOR INFLATABLE RIB-.25 FLANGE	
all	2	03 16494B	RIB BOLT DOWN 4"W SLOT-UHMW	
all	5	15K090	BUTSOKCAPSCR 3/8-16UNC2X1" BRASS	
all	6	15U242S	FLATWASH .453IDX.750ODX.032SS0	
all	7	03 16488C	RIB BOLTDOWN EPDM GASKET	
all	8	20C007G	THDLOCKSEAL LCT24231 RMUBL50CC	

2

Frame, Pivots and Suspension

2.2

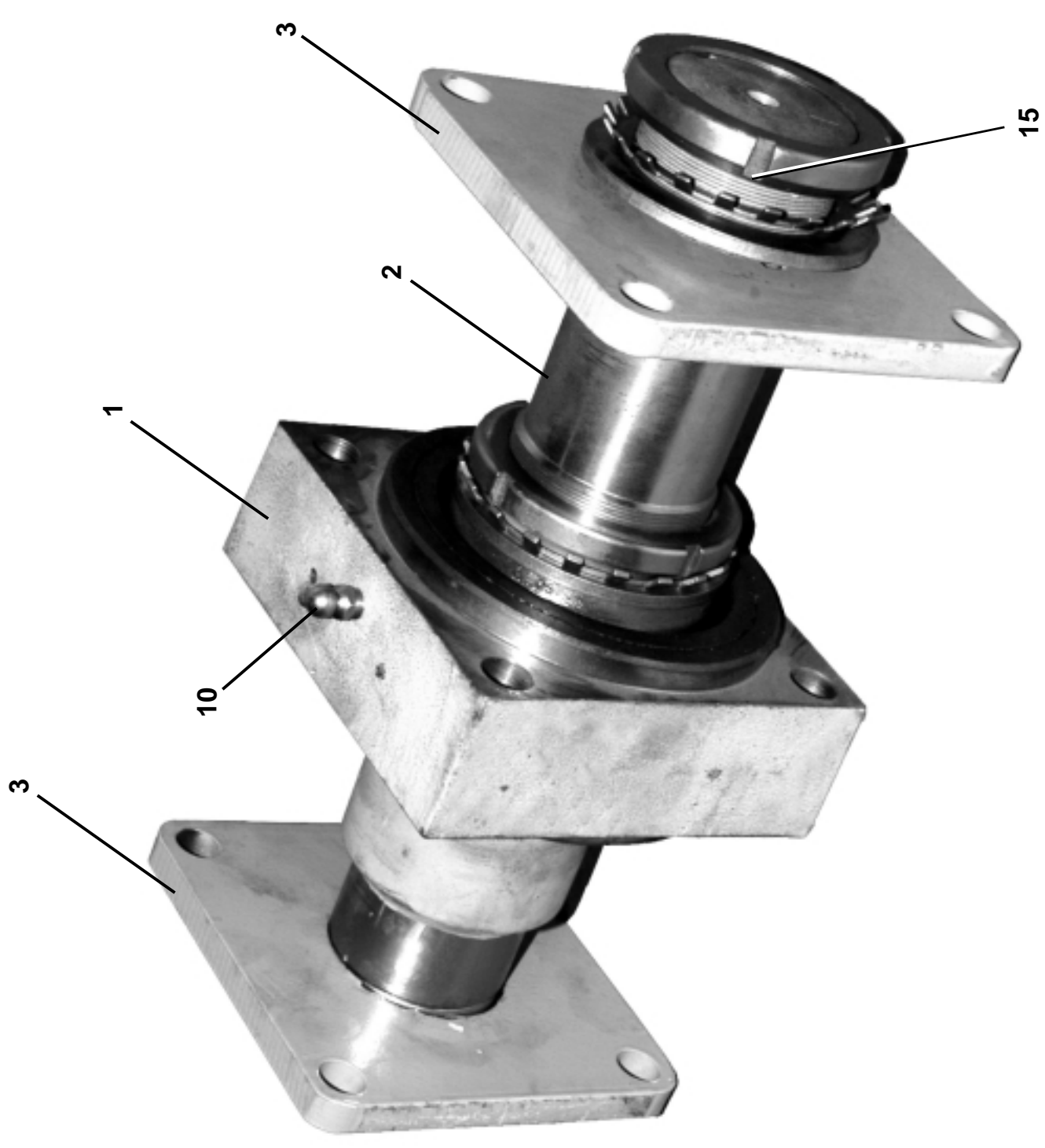
Pivot Ball Bushing Assembly
M7V4840C,M7V4836C

BMP050042/2005105V
 (Sheet 1 of 3)



Pellerin Milnor Corporation
 P. O. Box 400, Kenner, LA 70063-0400

Litho in U.S.A.



BASE FRAME

11,12,13
 8 PLACES

14,12,13
 8 PLACES

14,12,13
 8 PLACES

RIGHT PIVOT (SHOWN)
 LEFT IS OPPOSITE

TILT FRAME

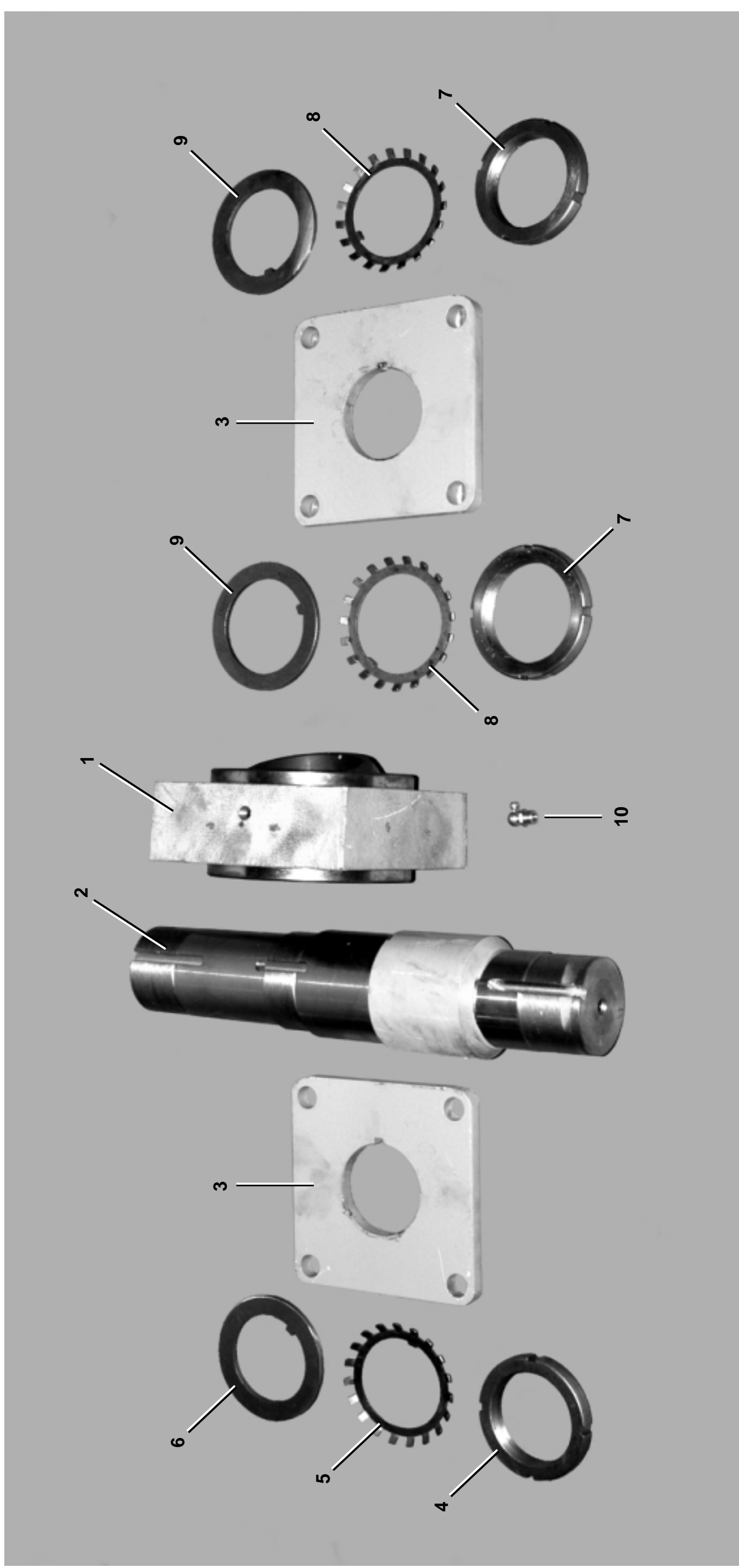
Pivot Ball Bushing Assembly
M7V4840C

BMP050042/2005105V
(Sheet 2 of 3)



Pellerin Milnor Corporation
P. O. Box 400, Kenner, LA 70063-0400

Litho in U.S.A.





Pellerin Milnor Corporation
P. O. Box 400, Kenner, LA 70063-0400

Litho in U.S.A.

Parts List—Pivot Ball Bushing			Description	Part Number	Comments
Used In	Item	Part Number			
<p>Find the correct assembly first, then find the needed components. The item letters (A, B, C, etc.) assigned to assemblies are referred to in the "Used In" column to identify which components belong to an assembly. The item numbers (1, 2, 3, etc.) assigned to components relate the parts list to the illustration.</p>					
-----ASSEMBLIES-----					
A	GBM16003		INSTL=BAL BUSH PIVOT M7E/E6N		
-----COMPONENTS-----					
all	1	ABM16003	ASSY=BAL BUSH PIV 42M7E64E6N		
all	2	X3 65150	SHAFT=3" BALL BUSH PIVOT		
all	3	X3 65153	MNT PLT=3" BALL BUSH PIVOT		
all	4	56AHN13	N13 BEARING LOCKNUT		
all	5	56ATW13S	TONGUEWASHER SPECIAL FOR N13		
all	6	56AHW13	W13 BEARING LOCKWASHER		
all	7	56AHN14	N14 BEARING LOCKNUT		
all	8	56ATW14	TONGUE WASH TIM K91514 FOR N14		
all	9	56AHW114	TW114 BEARING LOCWASHER		
all	10	54M023	GRSFIT 45DEG ALEMITE 1688-B		
all	11	15K227A	HXCAPSCR 5/8-11X4.5 GR8 ZINC		
all	12	15U315	LOKWASHER MEDIUM 5/8 ZINCPL		
all	13	15G238B	HEXFINNUT 5/8-11UNC2 GR8 ZINC		
all	14	15K214E	HXCAPSCR 5/8-11UNC2AX1.5 GR5 Z		
all	15	15E212	STDSQMACHKEY 5/16X2+1/2 C1018		

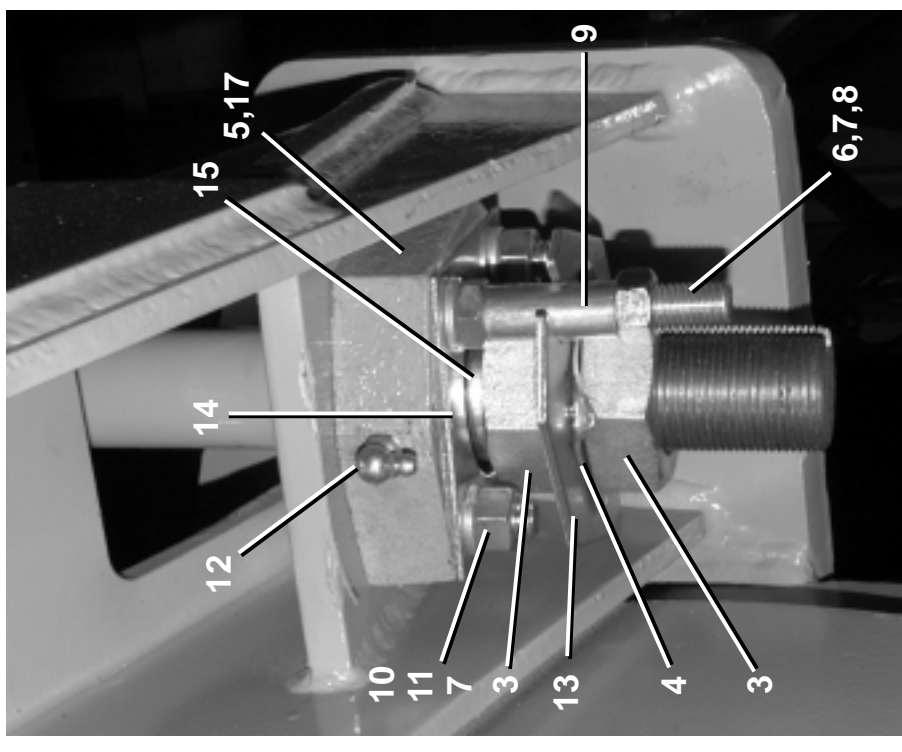
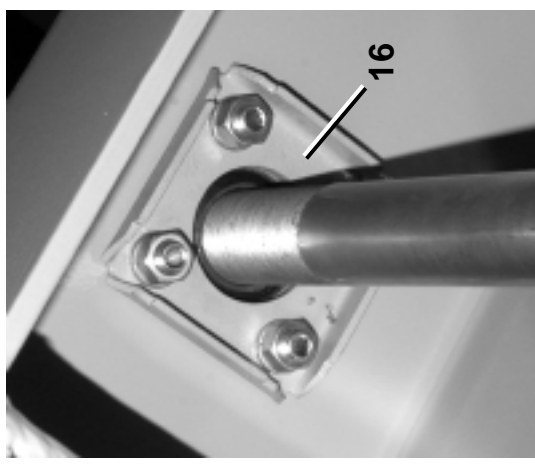
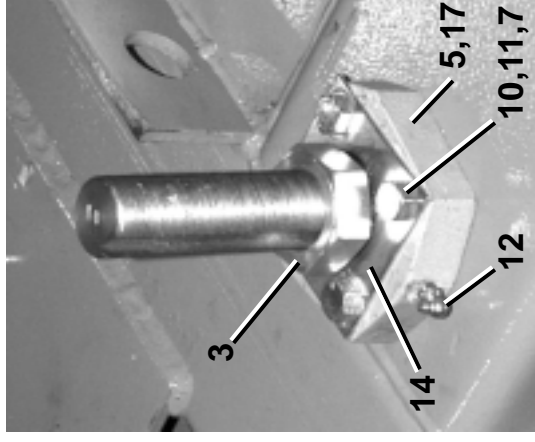
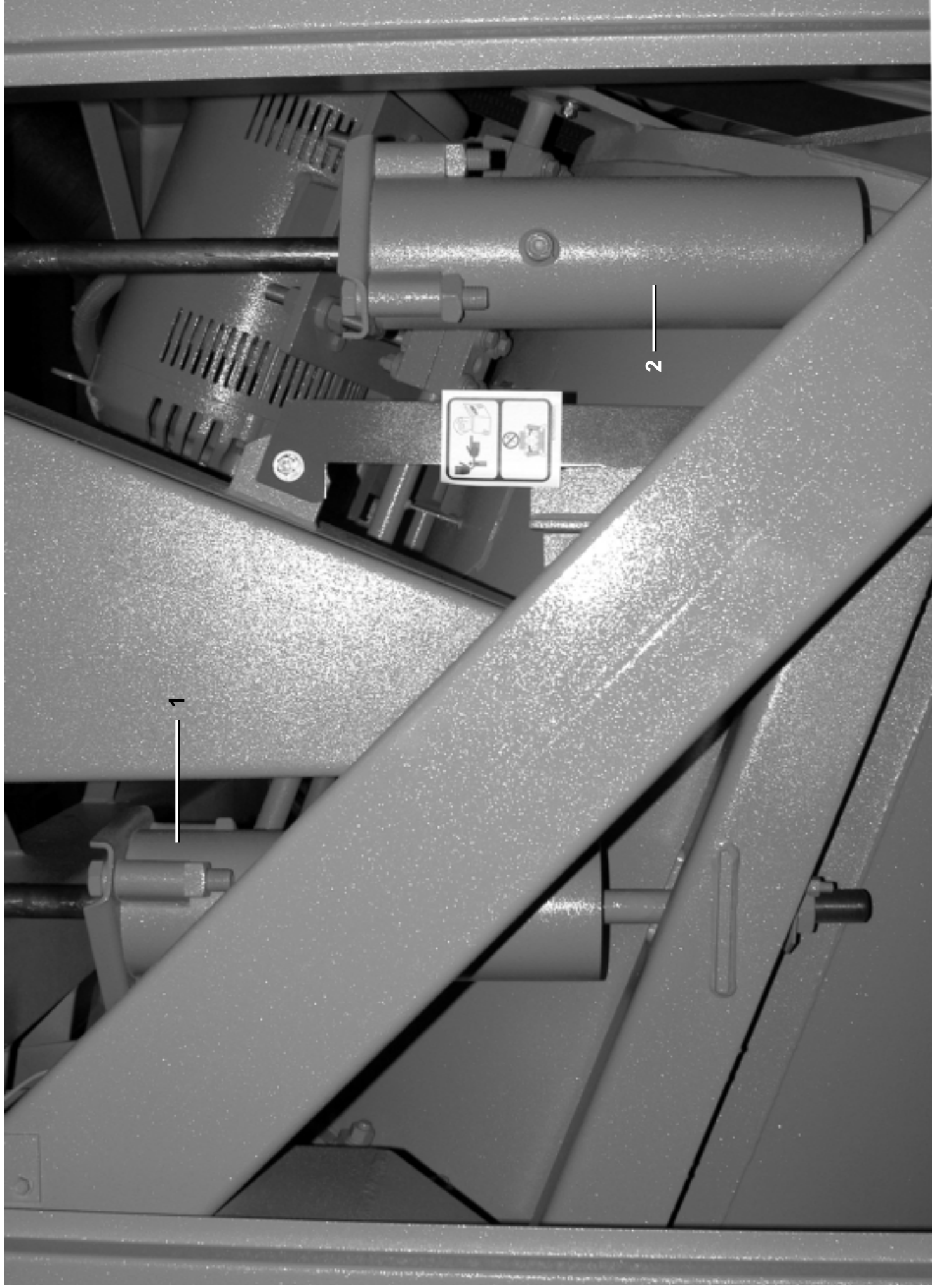
Suspension Hydrocushion Cylinder Installation
M7V4840C, M7V4836C

BMP050040/2005105V
 (Sheet 1 of 2)



Pellerin Milnor Corporation
 P. O. Box 400, Kenner, LA 70063-0400

Litho in U.S.A.





Pellerin Milnor Corporation
P. O. Box 400, Kenner, LA 70063-0400

Litho in U.S.A.

Used In		Item	Part Number	Description	Comments
<p>Parts List—Hydrocushion Cylinder Installation Find the correct assembly first, then find the needed components. The item letters (A, B, C, etc.) assigned to assemblies are referred to in the "Used In" column to identify which components belong to an assembly. The item numbers (1, 2, 3, etc.) assigned to components relate the parts list to the illustration.</p>					
-----ASSEMBLIES-----					
	A		GHC17000	HYDRCUSH CYL INSTL 4840M	
-----COMPONENTS-----					
all		1	AHC17000F	HYDRCUSH CYL ASSY FRNT 4840M	
all		2	AHC17000B	HYDRCUSH CYL ASSY REAR 4840M	
all		3	15G268	HXFJNUT 1+1/2-12UNF2B ZINC	
all		4	02 18256	LOKWASH-TONGUE 8/WEH ZINC	
all		5	X3 06252	RETAINER-BALBUSH=472WEDU	
all		6	15D119	HXTAPSCR 1/2-13X4 GR5 ZNC FTL	
all		7	15U300	LOKWASHER REGULAR 1/2 ZINC PLT	
all		8	15G231	HXFJNUT 1/2-13UNC2B ZINC G	
all		9	27B250	SPCRROLL.5ID1.5L.062T STLZNC	
all		10	15G230	HXNUT 1/2-13UNC2B SAE ZINC GR2	
all		11	15K191	HXCAPSCR 1/2-13UNC2AX2.5 GR5 Z	
all		12	54M025	HYDFIT 1/8"-90 ALEMITE 1613-B	
all		13	02 18795A	WASH-TIMING=HYDRO CYL 45DEG	
all		14	02 18534	HOLDPLATE= BALLBUSH ZNC/CAD	
all		15	02 18571A	PISTON ROD WASHER-.25"TK	
all		16	03 16224	INNER HSE FRNT X CHNL STFR	
all		17	54A705	BALBUSH 1.5 SKF#GEZ108ESAVE467	

Parts List, cont.—Document Name

Used In	Item	Part Number	Description	Comments

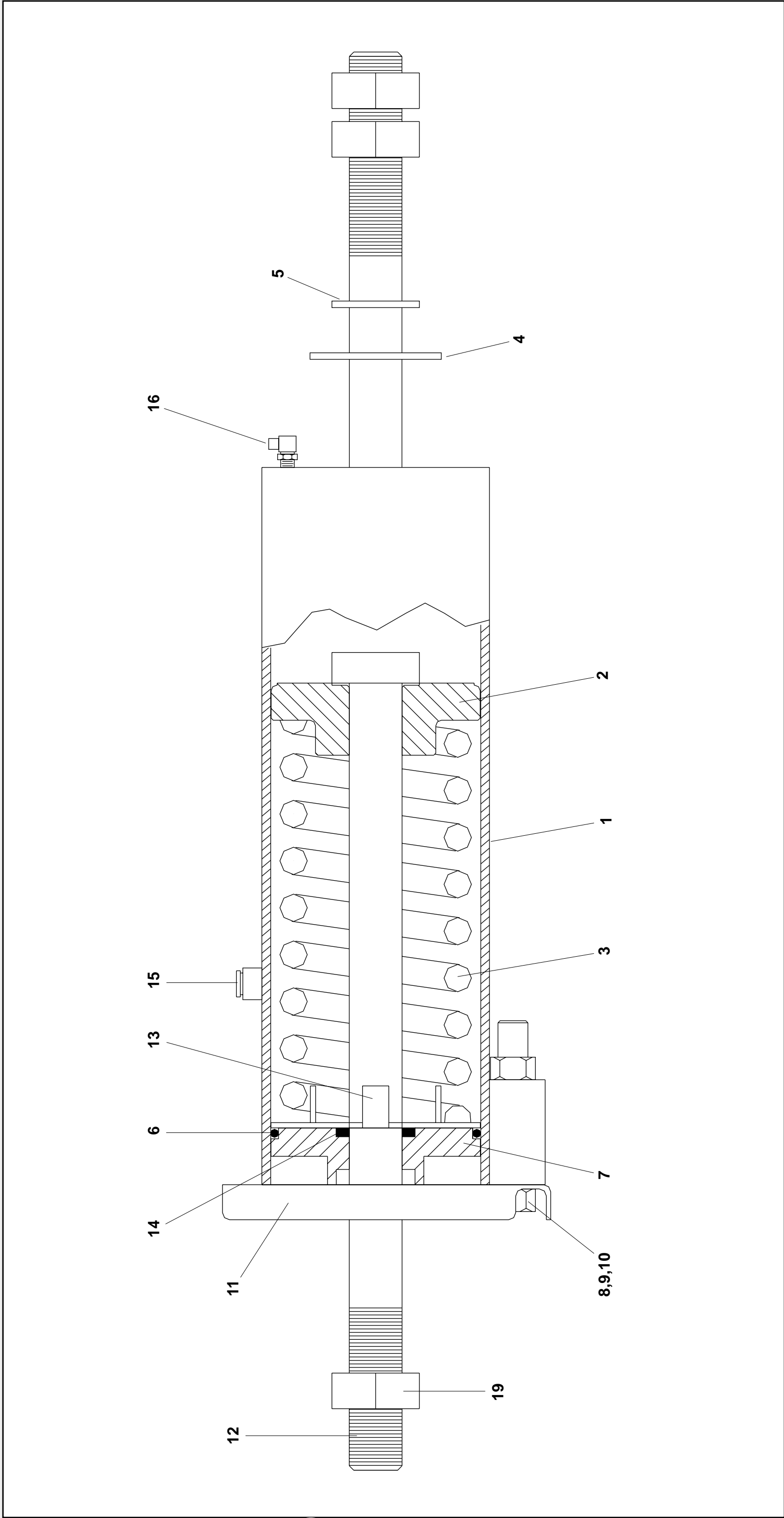
Hydrocushion Cylinders
M7V4840C, M7V4836C

BMP050041/2005255V
(Sheet 1 of 2)



Pellerin Milnor Corporation
P. O. Box 400, Kenner, LA 70063-0400

Litho in U.S.A.



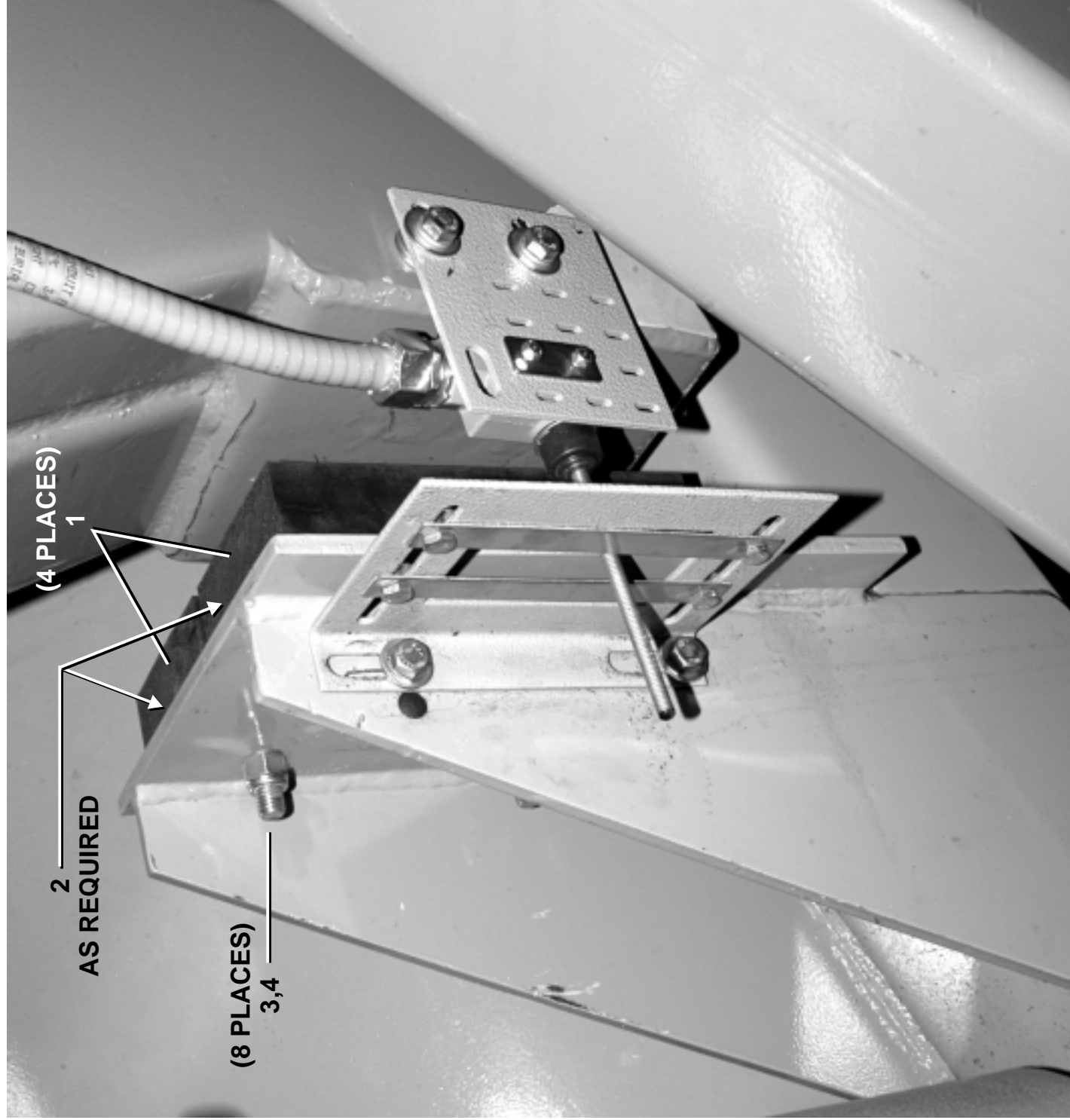


Pellerin Milnor Corporation
P. O. Box 400, Kenner, LA 70063-0400

Litho in U.S.A.

Parts List—Hydrocushion Cylinders
Find the correct assembly first, then find the needed components. The item letters (A, B, C, etc.) assigned to assemblies are referred to in the "Used In" column to identify which components belong to an assembly. The item numbers (1, 2, 3, etc.) assigned to components relate the parts list to the illustration.

Used In	Item	Part Number	Description	Comments
			-----ASSEMBLIES-----	
A		AHC17000F	HYDRCUSH CYL ASSY FRNT 4840M	FRONT CYLINDER
B		AHC17000B	HYDRCUSH CYL ASSY REAR 4840M	REAR CYLINDER
			-----COMPONENTS-----	
all	1	W3 17260	WLMT=HYDROCUSHION 4840M7	
all	2	X2 18228	PISTON=HYDROCYL 6"- 3 NOTCH	
A	3	03 09017	MAIN SPRING 700 LB/IN BL	
B	3	02 19039	MAIN SPRING 480LB/IN GREEN	
all	4	02 175034	SHIELD-BALLBUSH-4/HYDRO MACH	
all	5	02 02230	6 WATER BARRIER (NEOPRENE)	
all	6	60C159A	ORING 5.475ID 1/4CS BN70 #433	
all	7	02 18839A	MACHBUSH HYDRCYL CAP #433-OR	
all	8	15B237	HXCAPSCR 1-8UNC2AX5.5 SAEGR5 Z	
all	9	15U400	LOCKWASHER MEDIUM 1" ZINCPL	
all	10	15G255A	SQ Nut 1-8UNC2B SAE ZINC GR2	
all	11	02 18840A	UPCAP=HYDROCYL 42+52+60	
A	12	Y3 17097A	MACH=HYDROCUSH BOLT 35"	FRONT CYLINDER
B	12	Y3 17097B	MACH=HYDROCUSH BOLT 47"	REAR CYLINDER
all	13	02 18619	BUSHING RETAINER + CAD	
all	14	245040	SEAL URETHNE 1-7/16 2.25 13/32	
all	15	5SP0KGFSS	NPT PLUG 1/2 SOSOLID GALSTL	
all	16	5SP0GHFHKM	NPT PLUG 3/8"-HEXCMSMAGNETIC ZN	



Parts List—Tilt Stops

Find the correct assembly first, then find the needed components. The item letters (A, B, C, etc.) assigned to assemblies are referred to in the "Used In" column to identify which components belong to an assembly. The item numbers (1, 2, 3, etc.) assigned to components relate the parts list to the illustration.

Used In	Item	Part Number	Description	Comments
	A	GHF17001	-----ASSEMBLIES----- INST=FRAMES+PIVOTS-4840M	
			-----COMPONENTS-----	
	1	02 15450A	POS STOP LFT OUTSIDE PAD	
all	2	03 64681A	REST PAD:10GA SPACER	
all	3	15D119	HXTAPSCR 1/2-13X4 GR5 ZNC FTL	
all	4	15G234N	HXLOCKNUT NYL 1/2-13UNC2 STL/Z	

2

Shell and Door Assemblies

2.3

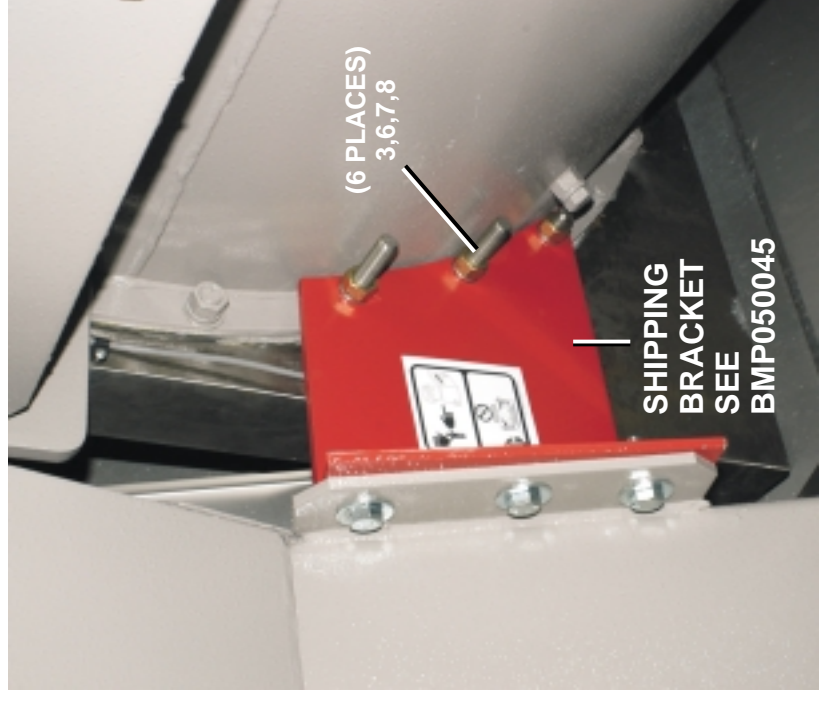
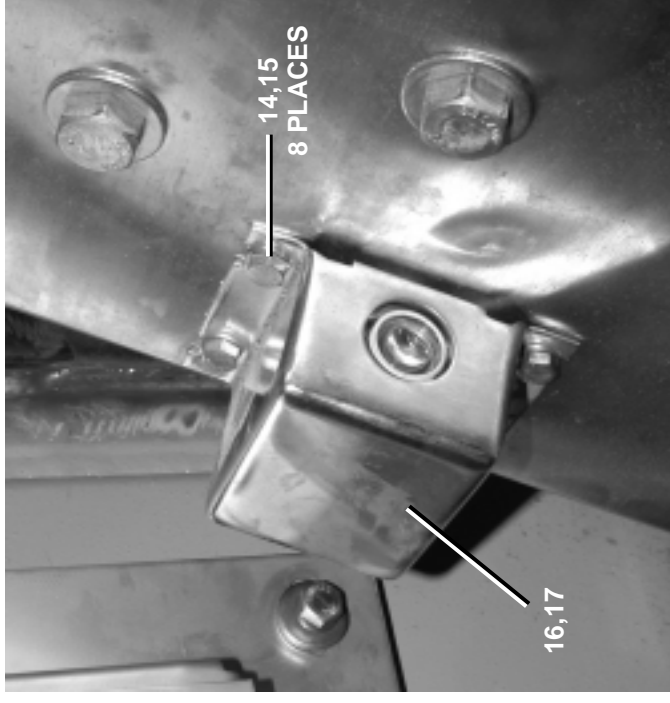
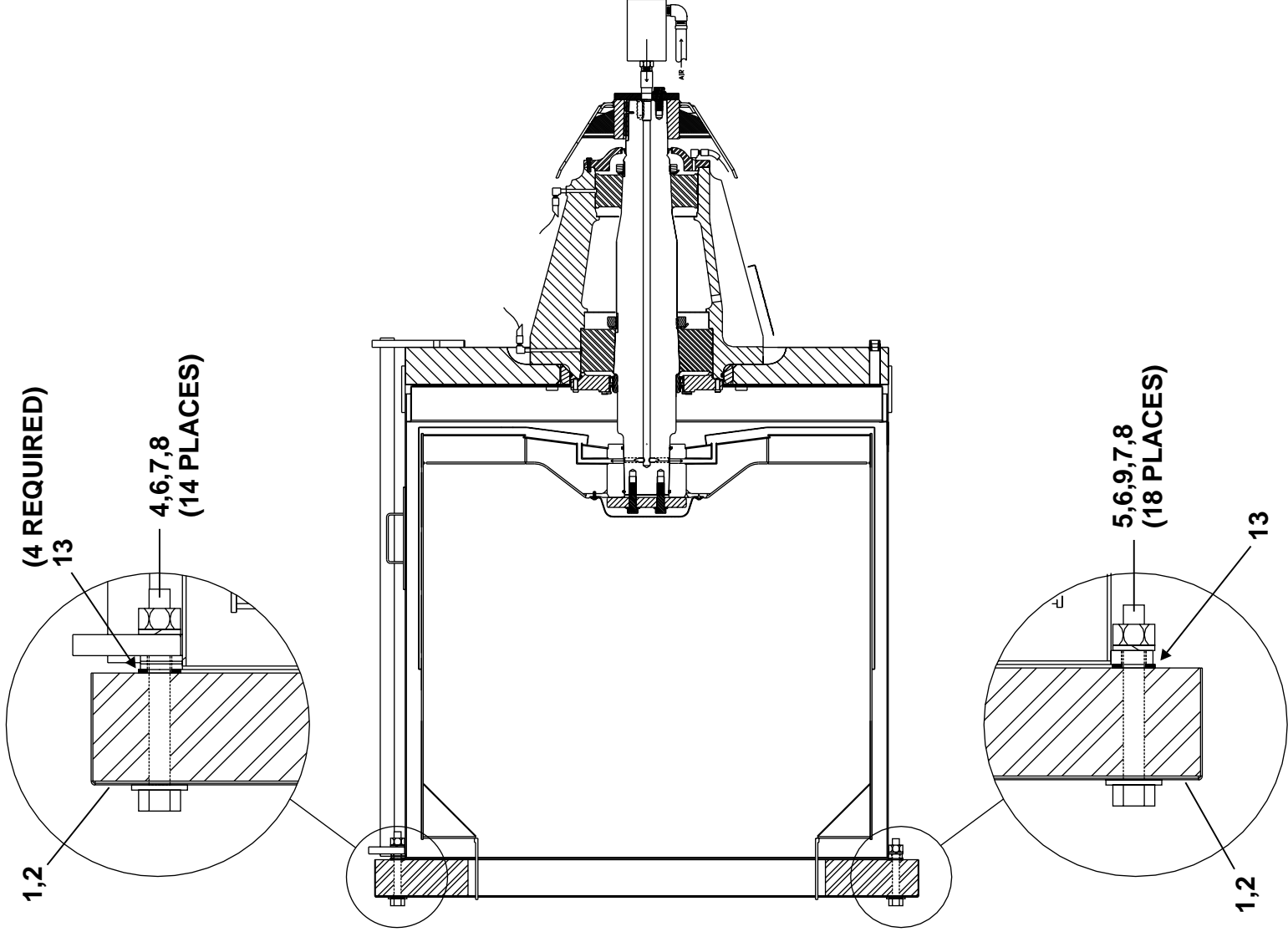
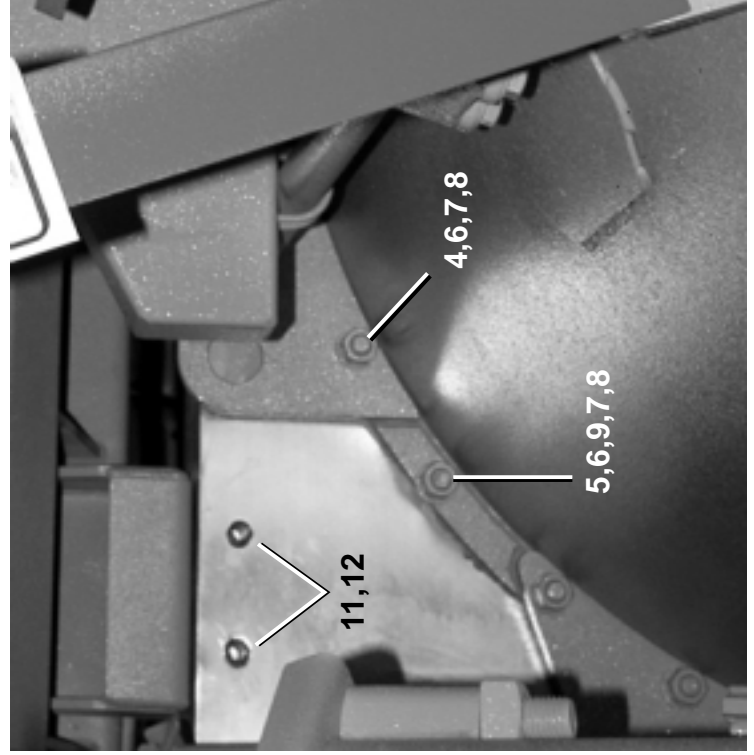
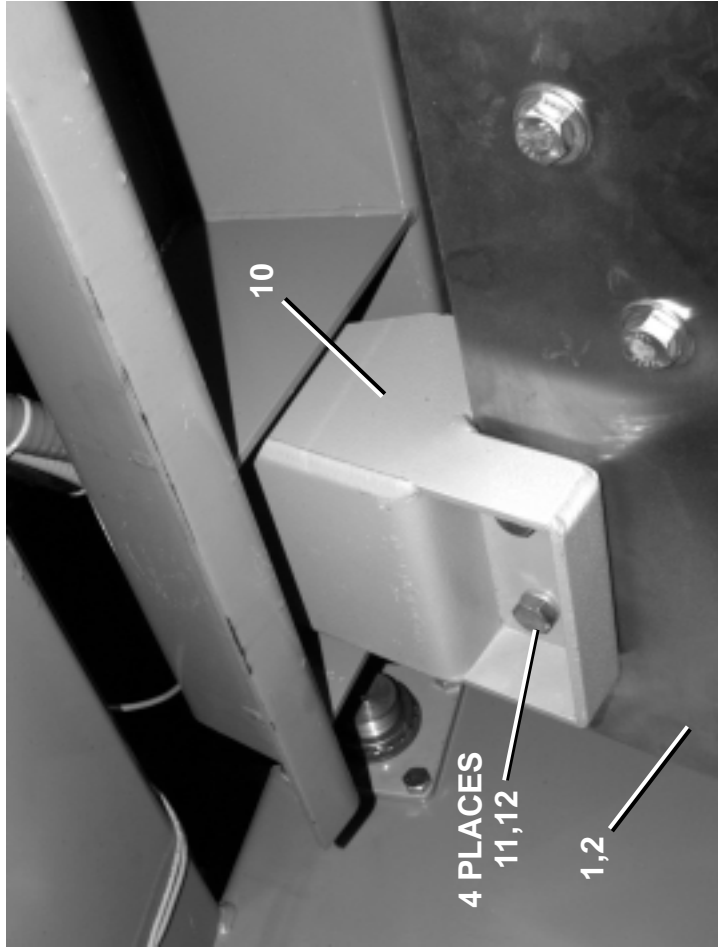
Shellfront Installation
M7V4840C, M7V4836C

BMP050056/2005255V
 (Sheet 1 of 2)



Pellerin Milnor Corporation
 P. O. Box 400, Kenner, LA 70063-0400

Litho in U.S.A.





Pellerin Milnor Corporation
P. O. Box 400, Kenner, LA 70063-0400

Litho in U.S.A.

Parts List—Shellfront Installation

Find the correct assembly first, then find the needed components. The item letters (A, B, C, etc.) assigned to assemblies are referred to in the "Used In" column to identify which components belong to an assembly. The item numbers (1, 2, 3, etc.) assigned to components relate the parts list to the illustration.

Used In	Item	Part Number	Description	Comments
			-----ASSEMBLIES-----	
	A	ASE17001	SHELL ASSY 4840M	
			-----COMPONENTS-----	
all	1	W3 17002	WLMT=4840 SHELLFRONT W/CLAD	
all	2	W3 17020	WLMT=SHELL 48M7	
all	3	W3 17003	BOLT=SHIP BRKT 4840M	
all	4	15K235GS	HEXCAPSCR 3/4-10X7SS #70377	
all	5	15K235ES	HEXCAPSCR 3/4"-10X6 SS #70375	
all	6	15U331	FLTWASHER 3/4X1+3/4 SS #71027	
all	7	15U350	LOCKWASHER 3/4 MED SS18-8	
all	8	15G244A	HEXNUT 3/4-10UNC2B BRASS	
all	9	15U494	3/4SAE CLPFW.812IDX1.5ODX.135T	
all	10	W3 17006	WLMT=48M SHLFRNT TILT BRKT	
all	11	15K225	HXCPCSCR 5/8-11X2+1/2	
all	12	15U315	LOKWASHER MEDIUM 5/8 ZINCPL	
all	13	03 48053B	GSKT=53+1/2BC 4840F 1/8 THK	
all	14	15K096	HEXCAPSCR 3/8-16UNC2X1SS18-8	
all	15	15U260	LOCKWASHER MEDIUM 3/8 SS18-8	
all	16	W3 16431	*WLMT=PHOTOEYE COVER 42M7E	
all	17	03 16432	PHOTOEYE MNT BRKT 42M7E	

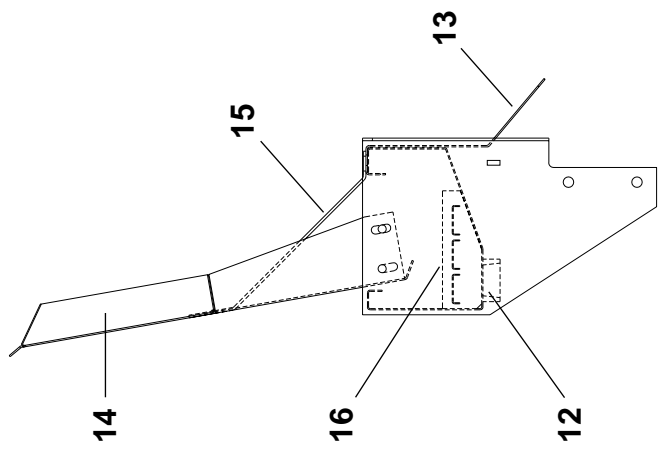
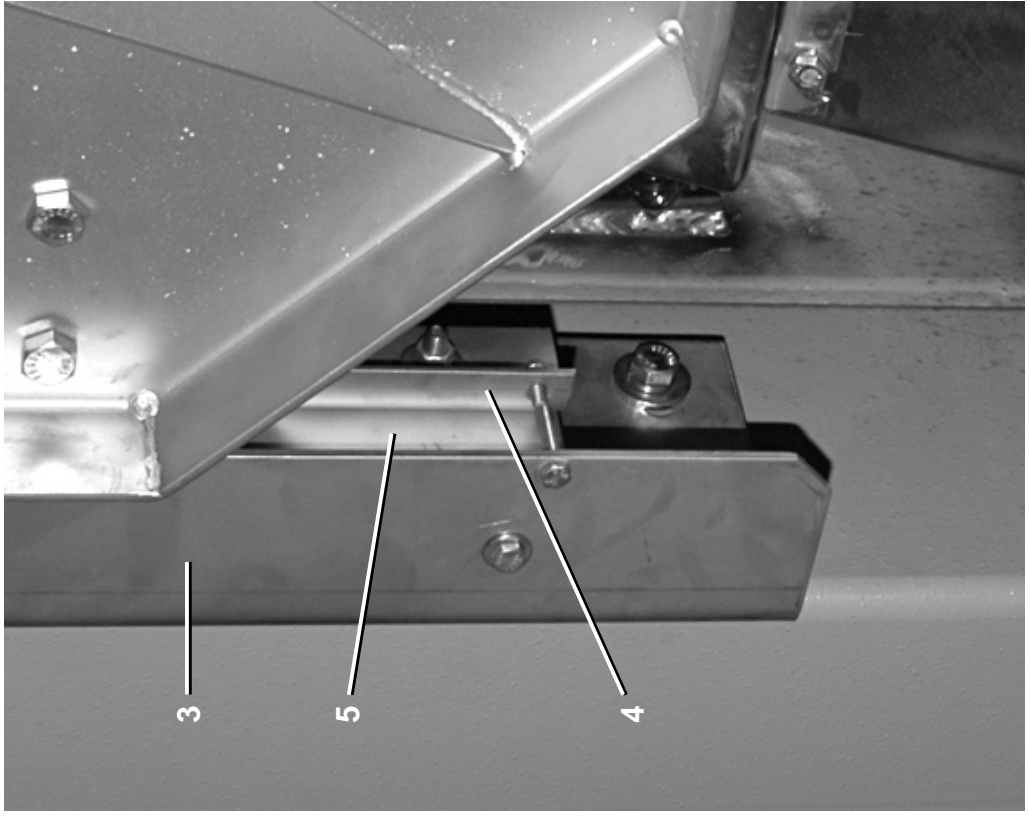
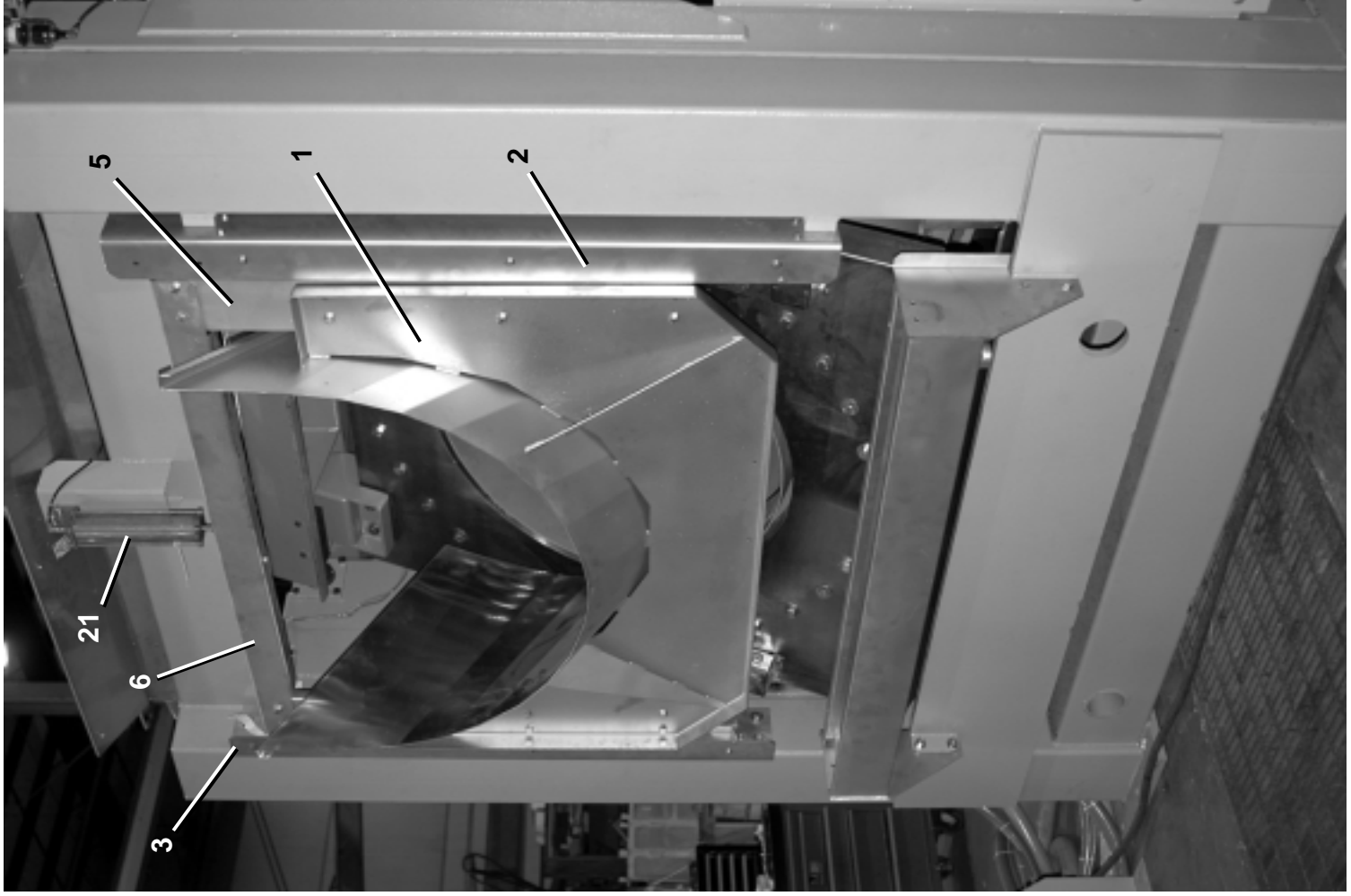
Load Chute Assembly
M7V4840C, M7V4836C

BMP050047/2005105V
 (Sheet 1 of 3)



Pellerin Milnor Corporation
 P. O. Box 400, Kenner, LA 70063-0400

Litho in U.S.A.



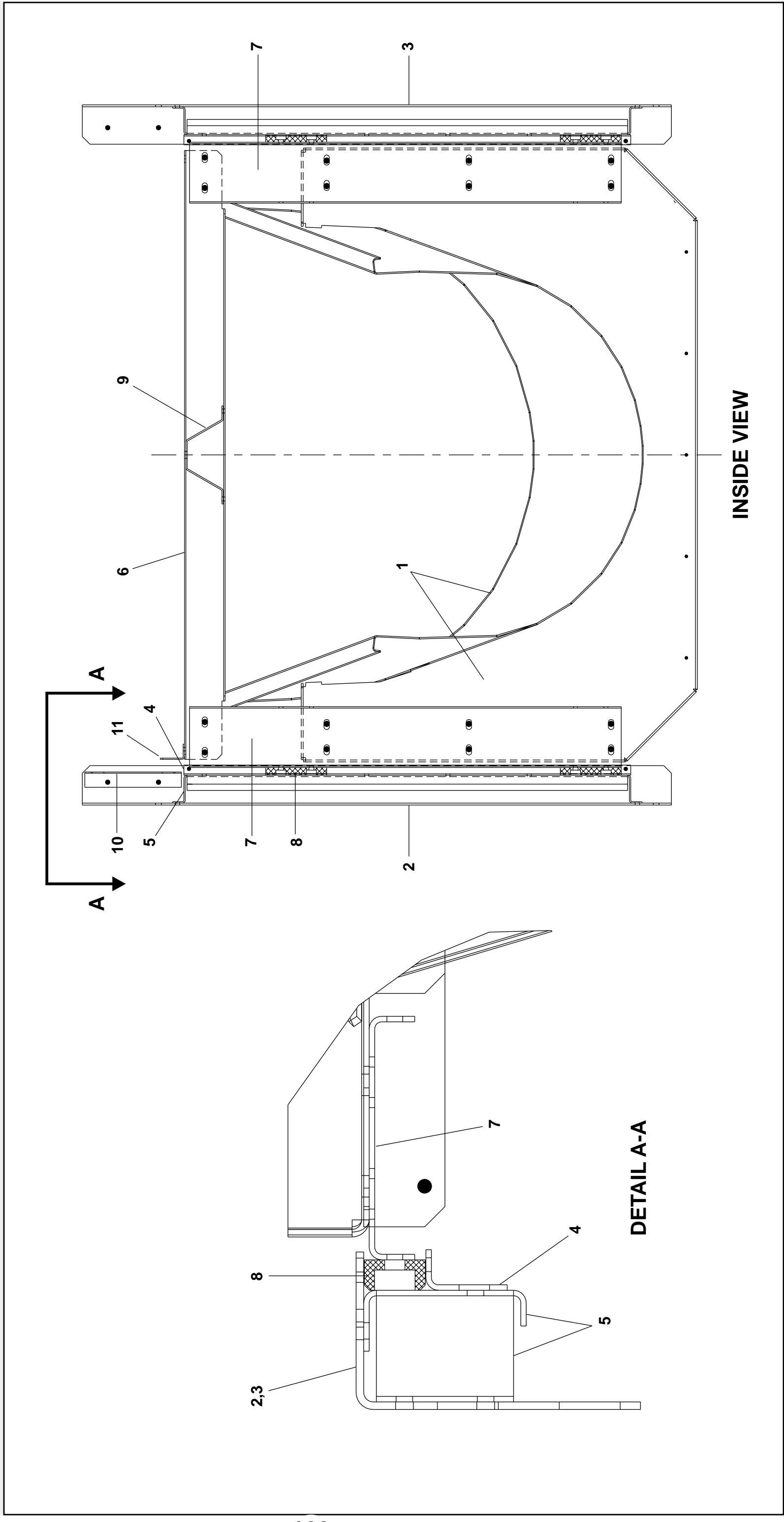
Load Chute Assembly
M7V4840C, M7V4836C

BMP050047/2005105V
 (Sheet 2 of 3)



Pellerin Milnor Corporation
 P. O. Box 400, Kenner, LA 70063-0400

Litho in U.S.A.



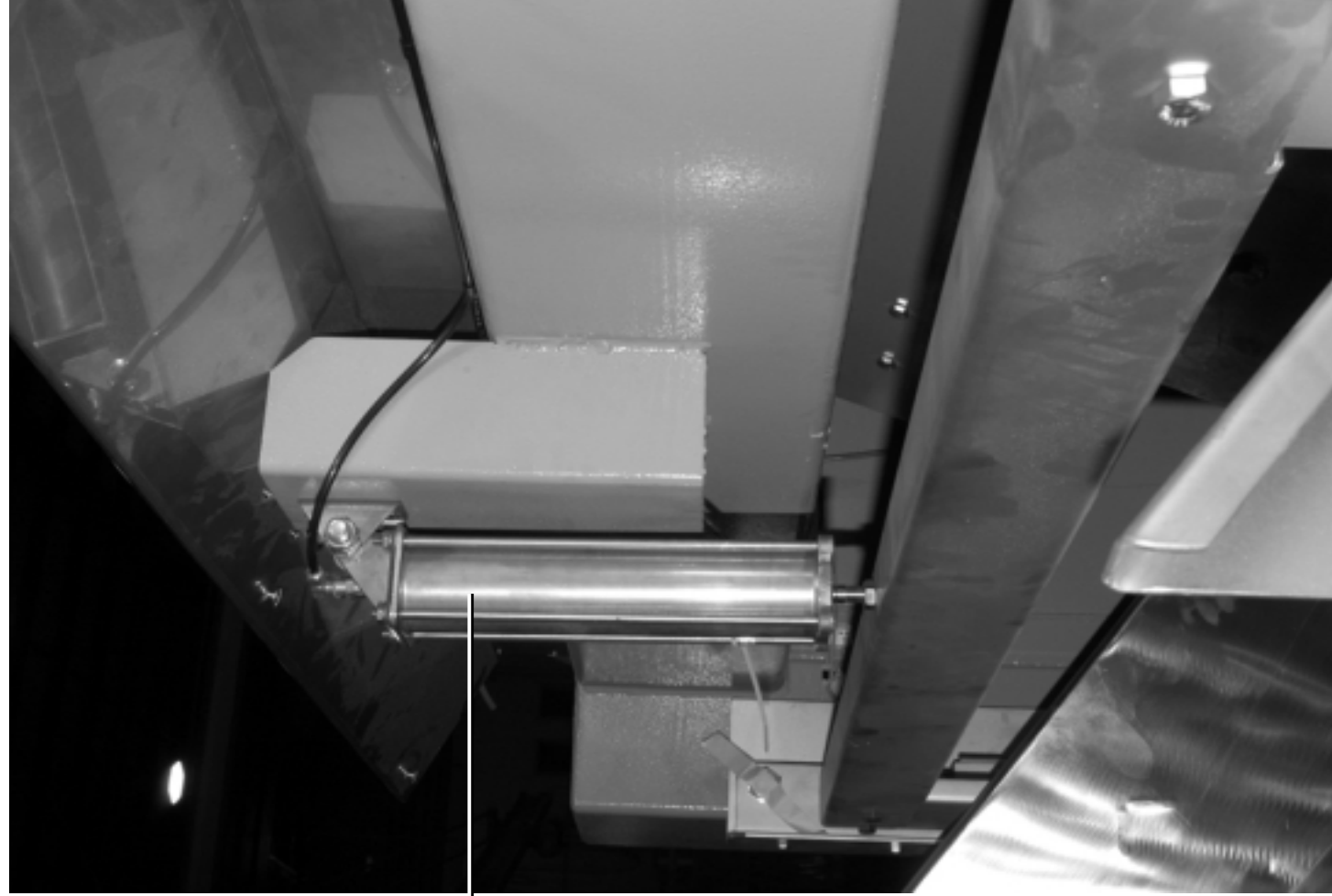
Load Chute Assembly M7V4840C, M7V4836C



Pellerin Milnor Corporation
P. O. Box 400, Kenner, LA 70063-0400

Litho in U.S.A.

BMP050047/20005105V
(Sheet 3 of 3)



21
(SEE
BMP050058)

Parts List—Load Chute Assembly

Find the correct assembly first, then find the needed components. The item letters (A, B, C, etc.) assigned to assemblies are referred to in the "Used In" column to identify which components belong to an assembly. The item numbers (1, 2, 3, etc.) assigned to components relate the parts list to the illustration.

Used In	Item	Part Number	Description	Comments
			-----ASSEMBLIES-----	
A		AGS17010	LOADCHUTE ASSEMBLY-M7V4840	
B		AGS17011	LOADCHUTE SCUPPER ASSY-4840M	
C		A40 01800	* AIRCYL,2-WAY =52DRYELL	
			-----COMPONENTS-----	
all	1	W3 17215	WLMT=4840M LOAD CHUTE	
all	2	03 17205	LOAD CHUTE FRAME RT SIDE	
all	3	03 17205A	LOAD CHUTE FRAME LF SIDE	
all	4	03 17201	LOADCHUTE ADJUSTING TRACK	
all	5	03 17204	LOADCHUTE TRACK-36"LG	
all	6	03 17209	LOADCHUTE LIFT BAR	
all	7	03 17210	LOADCHUTE SIDE SLIDER	
all	8	04 23322	UPPER BED SLIDER PAD	
all	9	03 17208	AIRCYL ROD END BRKT	
all	10	03 17211	LOADCHUTE PROX.SW BKT-4840M	
all	11	03 17212	LOADCHUTE TARGET-M7V4840	
all	12	W3 17223	LOADCHUTE SCUPPER WLMT-4840M	
all	13	03 17225	SCUPPER FRONT PANNEL	
all	14	03 17226	SCUPPER BACK PANNEL	
all	15	03 17227	BACK PANEL BRACE	
all	16	W3 17228	SCUPPER DECK WLMT-4840M	
all	17	60E099	HOSE1.5"WIREINSERT#7216-TRANS	
all	18	5N1KCLSS42	NPT NIP 1.5XCLS TBE 304SS SK40	
all	19	5SB1K1ESFO	NPTHEXBUSH 1.5X1.25 SS304 150#	
all	20	51E098AS	KINGREDNIP1.5IDX1.25MP#STC2015	
all	21	A40 01800	* AIRCYL,2-WAY =52DRYELL	

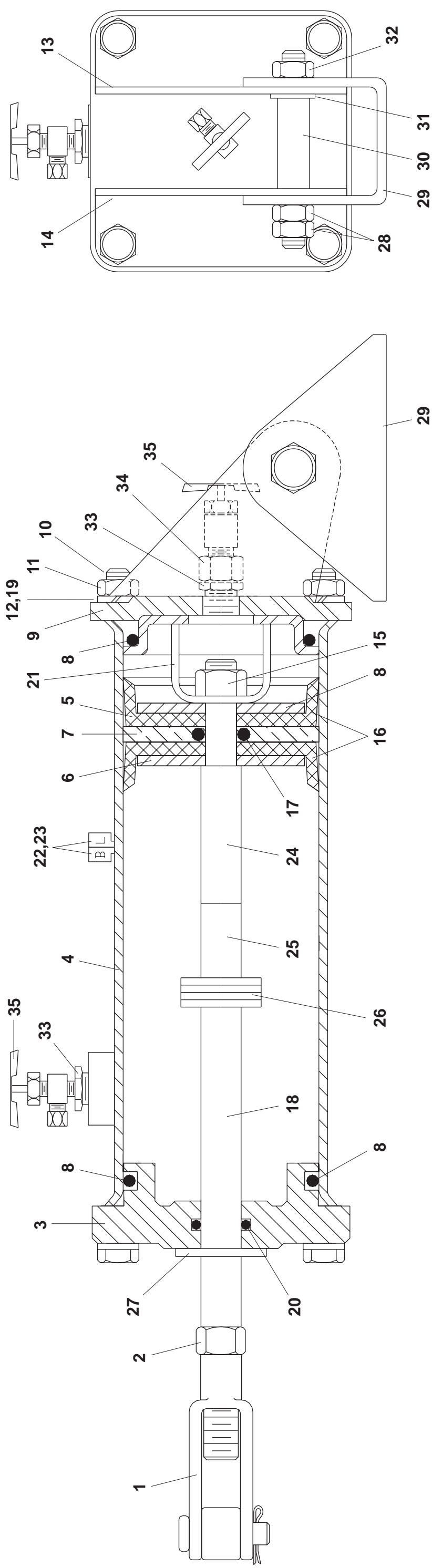
Air Cylinder 2-Way

BMP050058/2008105B
(Sheet 1 of 2)



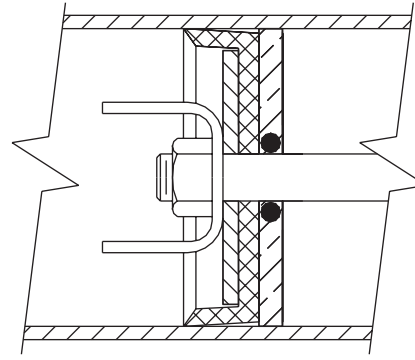
Pellerin Milnor Corporation
P. O. Box 400, Kenner, LA 70063-0400

Litho in U.S.A.

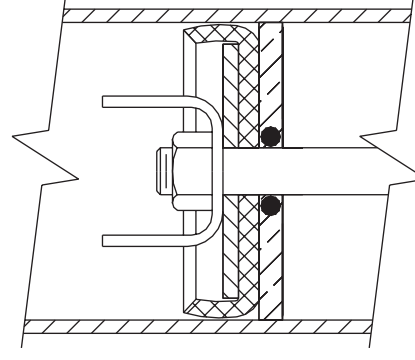


PISTON CUP WASHER INSTALLATION:

WHEN INSTALLING PISTON CUPS
TIGHTEN NUT UNTIL IT IS JUST
BARELY POSSIBLE TO TURN THE PISTON
CUP AND WASHER ASSEMBLY, AFTER
TIGHTENING PISTON CUP SHOULD APPEAR
AS SHOWN IN DETAIL "A".



DETAIL "A"



DETAIL "B"

TIGHTENING THE NUT TOO TIGHT
CAUSES THE PISTON CUP TO EXTRUDE
TO THE SHAPE SHOWN IN DETAIL "B"
AND MAY CAUSE PISTON TO BIND IN
CYLINDER.

NOTE: NUT IS SELF-LOCKING AND DOES
NOT NEED TO BE DRAWN TIGHT TO LOCK
ON AIR CYLINDER.



Pellerin Milnor Corporation
P. O. Box 400, Kenner, LA 70063-0400

Litho in U.S.A.

Used In	Item	Part Number	Description	Comments
			ASSEMBLIES-----	
A		A40 01800	* AIRCYL,2-WAY =52DRYELL	
B		AAC03001	AIRCYL DBL ACT=S/S HWD	
			COMPONENTS-----	
all	1	17A020	ADJ CLEVIS MACHINED 1/2-13 ZIN	
A	2	15G231	HXFJNMINUT 1/2-13UNC2B ZINC G	
B	2	15G231S	HXFJNMINUT 1/2-13UNC2B SS18-8	
all	3	02 18660	CYLHEAD BRASS-DRILL AND TAP	
all	4	W3 06315A	* AIRCYL=52 DRYELL	
all	5	02 02194	PISTON CUP=DUMPVALVE 2+3/8"	
all	6	02 02085	UP WASHER=2"OD=PISTON CUP	
all	7	02 02105B	2.38"ACYL BRASS PISTONCUP WSHR	
all	8	60C132	ORING 2"IDX3/16CS BUNA70 #329	
A	9	02 02101	CYLHEAD W/TAPPED HOLE	
B	9	02 02101S	CYLINDER HEAD TAP.HOLE (SS)	
A	10	03 06314	TIEROD=AIR-CYL ACTUATOR-ZINC	
B	10	03 06314S	TIE ROD=AIR-CYL ACTUATOR=S/S	
A	11	15G185	HXNUT 5/16-18UNC2B SAE ZINC GR	
B	11	15G188	HEXLOKNUT 5/16-18 BRASS	
A	12	15U210	LOKWASHER MEDIUM 5/16 ZINCPL	
B	12	15G235G	HXFJNMINUT 9/16-12UNC2B SS	
A	13	02 02550	BRKT=AIRCYL-RIGHT ZINC/CAD	
B	13	02 02550S	BRKT=AIRCYL RIGHT S/S	
A	14	02 02547	BRKT=AIRCYL-LFT ZINC/CAD	
B	14	02 02547S	BRKT=AIRCYL LEFT S/S	
all	15	15G220	NUTLOK THINHX 3/8-24 SS/NYL	
all	16	02 02185	WASHER=PISTON CUP COMP LIMIT	
all	17	60C106	ORING 5/16ID 1/16CSBUNA70#011	
all	18	03 06313	STEM=AIR CYL 304SS	
all	19	15U185	FLATWASHER(USS STD) 1/4" ZNC P	
all	20	60C110	ORING 1/2IDX3/32CS BUNA70 #112	
all	21	03 01313	STOP=AIR CYL W/2+11/16STROKE	
all	22	20L601B	ID TAG NAT'L#1614 ALUM EMB "B"	

Used In	Item	Part Number	Description	Comments
all	23	20L601U	ID TAG NAT'L#1614 ALUM EMB "U"	
all	24	27B250	SPCRROLL.5ID1.5L.062T STLZNC	
all	25	27B240	SPCRROLL.5ID.813L.062T STLZNC	
all	26	15U243	FLTWASHER 7/8ODX33/64IDX16GA Z	
A	27	17B012	EXTRETRING IND#1000-50-ST-ZD Z	
B	27	17B012B	EXTRETRING IND#1000-50 304SS	
A	28	15G235F	HXFJNMINUT 9/16-12UNC2B ZINC G	
Bl	28	15G235G	HXFJNMINUT 9/16-12UNC2B SS	
A	29	02 02556	SUPPORT=AIRCYL 12GA ZINC PLT	
B	29	02 02556S	SUPPORT=AIRCYL 12GA S/S	
A	30	27B2750L0T	SPC RROLL.562ID.937L.048T ZNK	
B	30	27B2750LOU	SPCRROLL.562IDX.937LX.048T SS	
A	31	15U311A	FLTWASHER9/16 ASME/B18.22.1TYP	
B	31	15U311C	FLATWASHER .578X.1062X.063	
all	32	15K206	HEXCAPSCR 9/16-12X2.5 ZC GR5	
all	33	5SB0E0CBEO	NPTHEXBUSH 1/4X1/8 BRASS 125#	
all	34	51A001	ADAPTER 1/8 PT BRASS	
all	35	96H018	ANGLE NEEDLE VLV 1/4" X 1/8MP	

2

Hydraulic Devices

2.4

Hydraulic Schematic

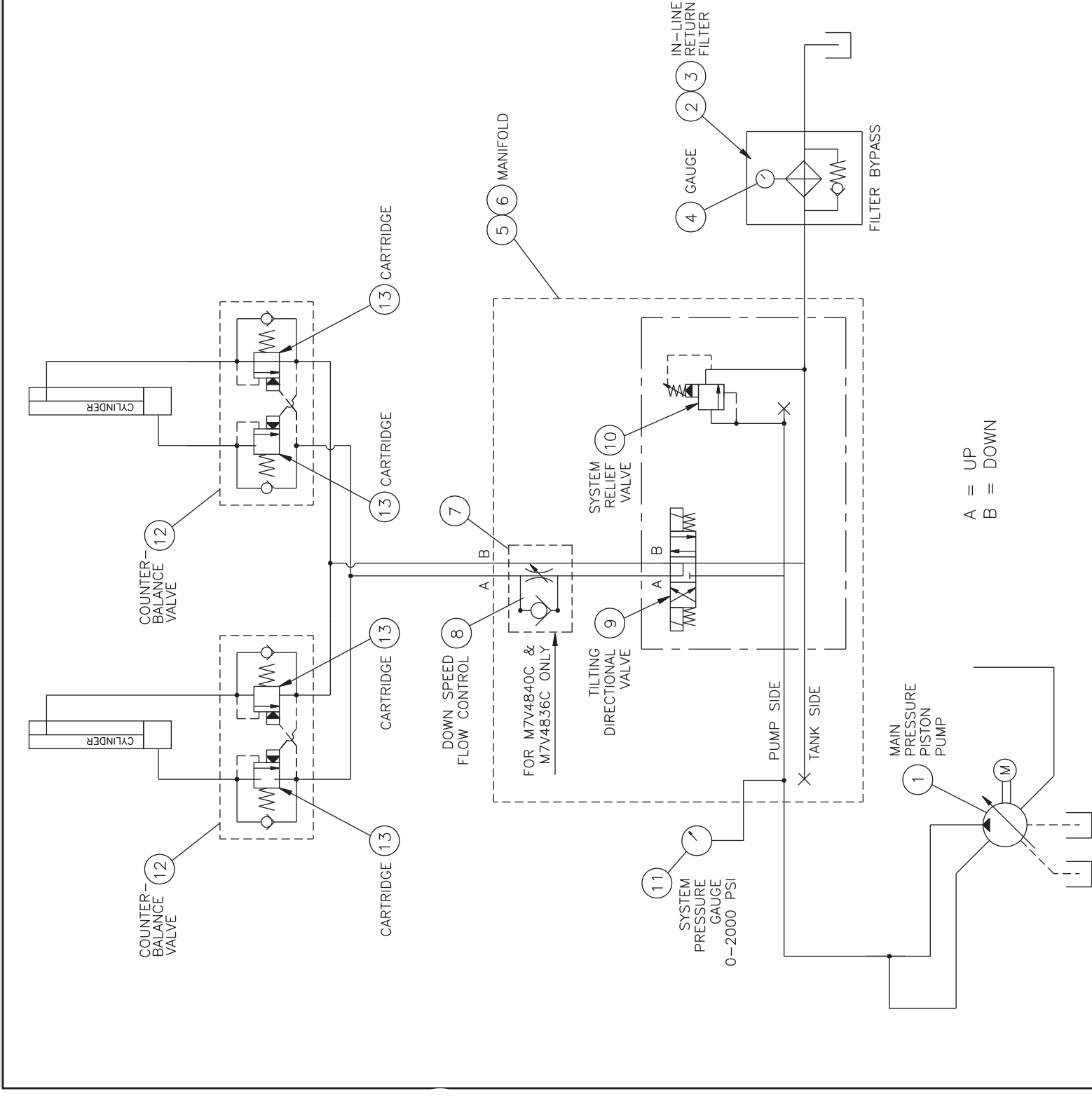
MXS4232, M9V4232, M9V4840, M7V4836



Pellerin Milnor Corporation
P. O. Box 400, Kenner, LA 70063-0400

BMP050060/2013342B
(Sheet 1 of 1)

Litho in U.S.A.



A = UP
B = DOWN

Parts List—Hydraulic Schematic
Find the correct assembly first, then find the needed components. The item letters (A, B, C, etc.) assigned to assemblies are referred to in the "Used In" column to identify which components belong to an assembly. The item numbers (1, 2, 3, etc.) assigned to components relate the parts list to the illustration.

Used In	Item	Part Number	Description	Comments
			-----ASSEMBLIES-----	
A	AHT16004A		MXV=HYDR POWER UNIT UNIVOLT	MXS4232, M9V4232
B	AHT17000A		4840M7=HYDR POWER UNIT UNIVOLT	M9V4840, M7V4836
			-----COMPONENTS-----	
A	1	27E550566	PISTON PUMP-KAWASAKI(50BAR) K3VL 80/B	
B	1	27E550466	PISTON PUMP-KAWASAKI=35-BAR	
all	2	27E7106	IN-LINE RETURN FILTER	
all	3	27E7106A	FILTER ELEMENT-REPLACEMENT	
all	4	27E7103A	GAUGE=WIKA 1/8NPT(ON 27E7103)	
all	5	27E5506E	DAMAN MANIFOLD #AD05HP013S/S	
B	6	96DH490D	RETAINER/SEAL,SUN#990120009	
B	7	96DH490B	BODY, SUN #DJD	
B	8	96DH490C	CARTRIDGE, SUN #NCFB-LCN	
all	9	96RH711E37	DIRECTIONAL CONT. VLV.D05-NG10	
all	10	27E5506F	SUN HYD. CARTRIDGE #RDFALAN	
all	11	30N125G	GAUGE 0-2000PSIBAR 1/4 BACK	
all	12	96DH472	COUNTERBALANCE VALVE-SUN BODY	
All	13	96DH472A	CARTRIDGE, COUNTERBALANCE VLV.	

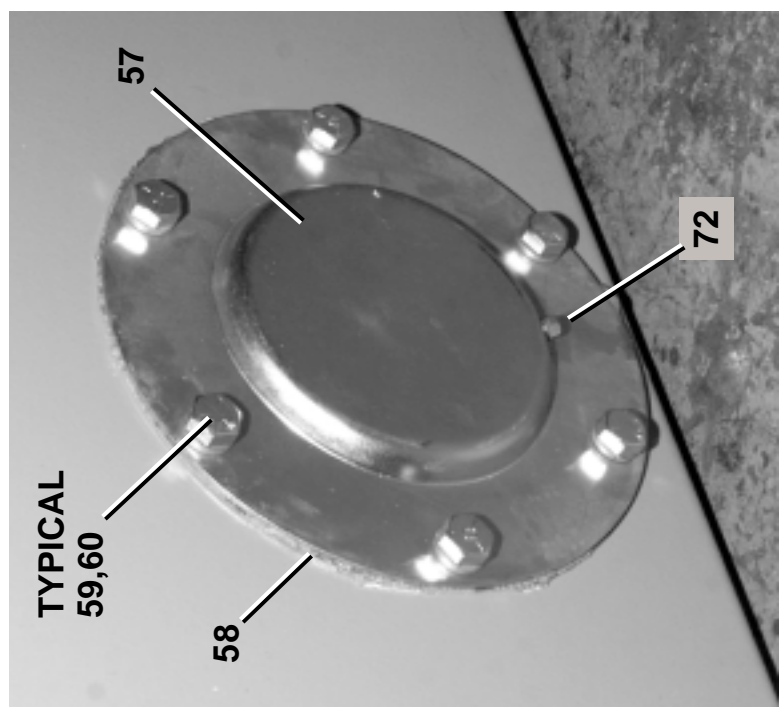
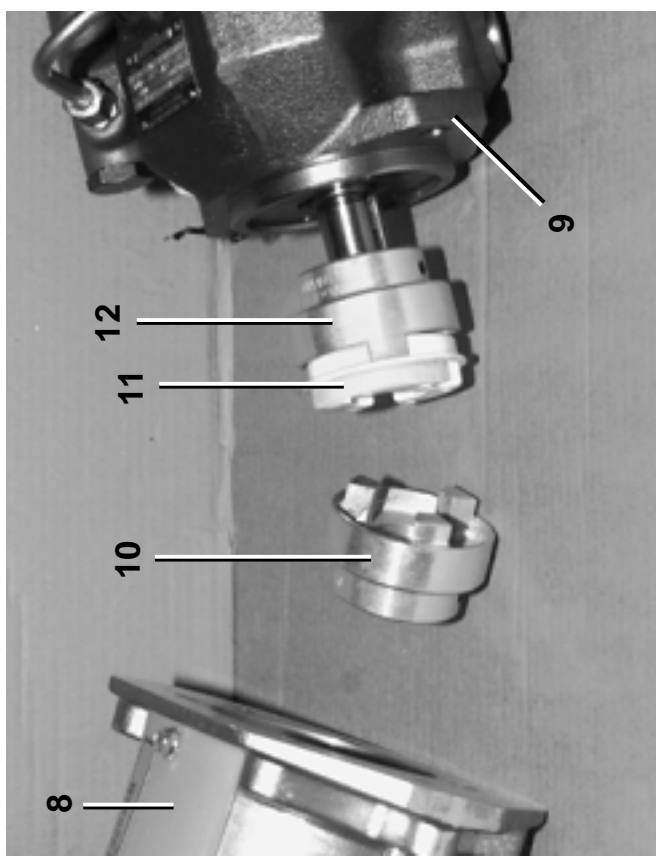
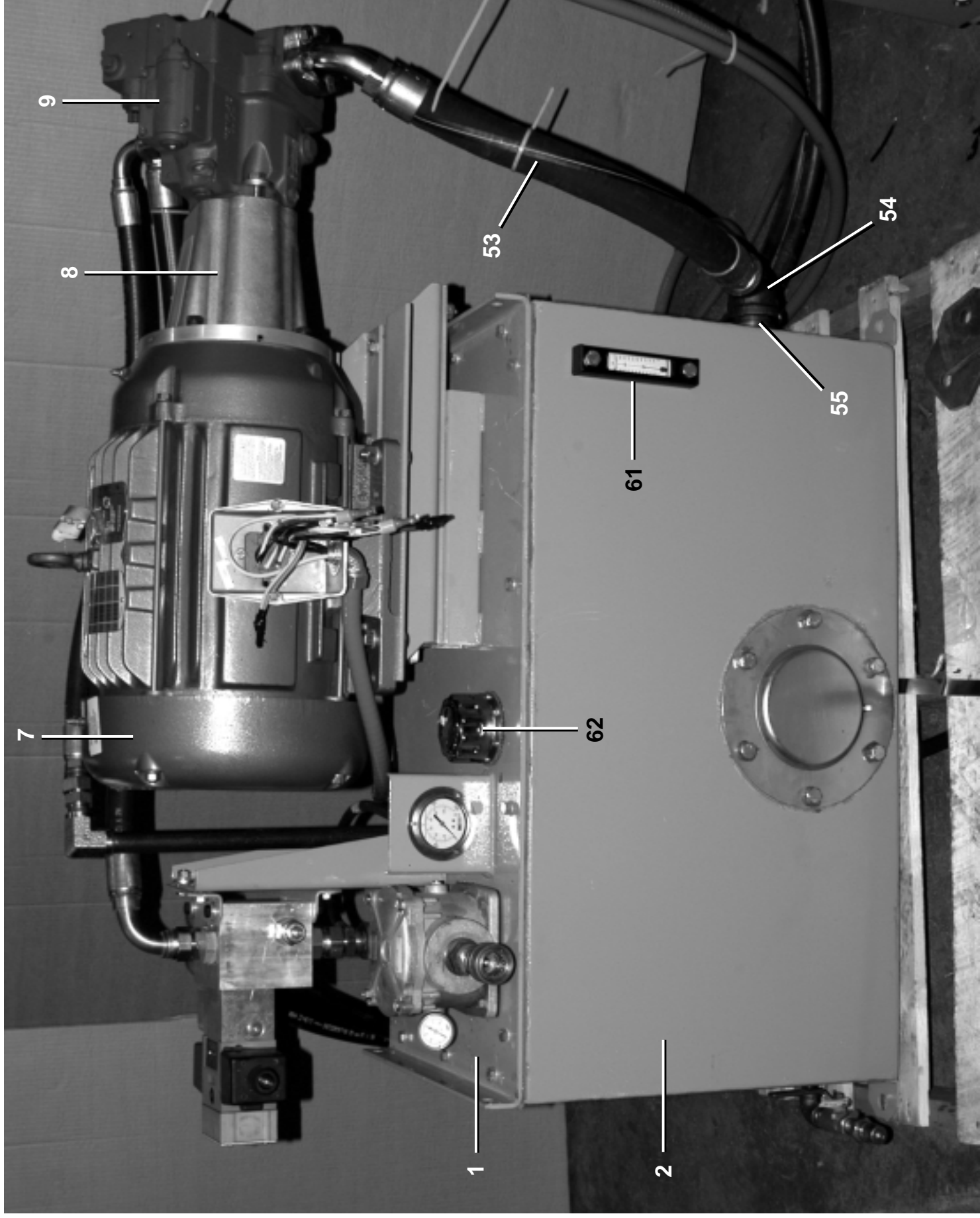
Hydraulic Tank
M7V4840C

BMP050035/2005105V
(Sheet 1 of 6)



Pellerin Milnor Corporation
P. O. Box 400, Kenner, LA 70063-0400

Litho in U.S.A.



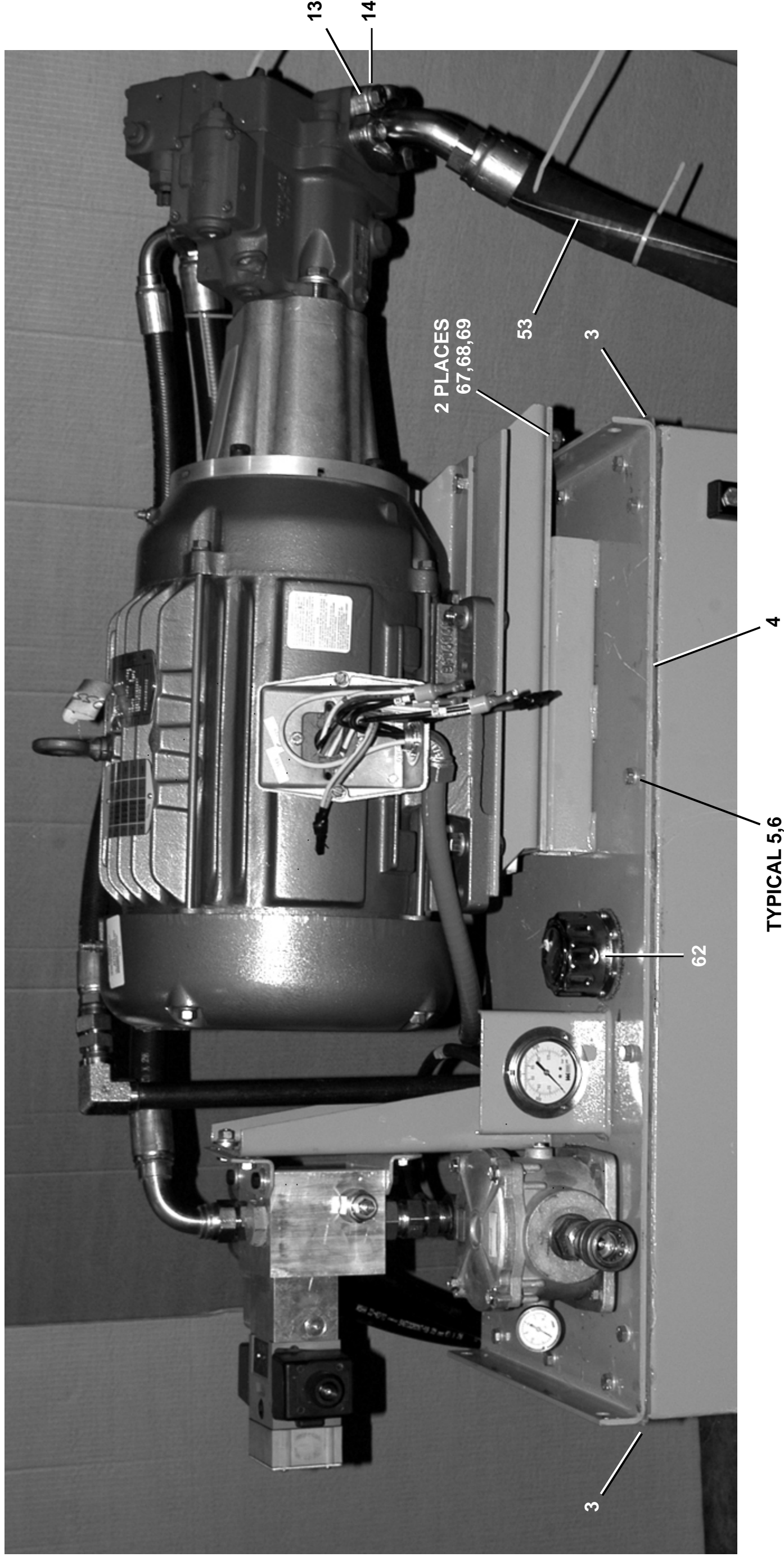
Hydraulic Tank M7V4840C

BMP050035/2005105V
(Sheet 2 of 6)



Pellerin Milnor Corporation
P. O. Box 400, Kenner, LA 70063-0400

Litho in U.S.A.



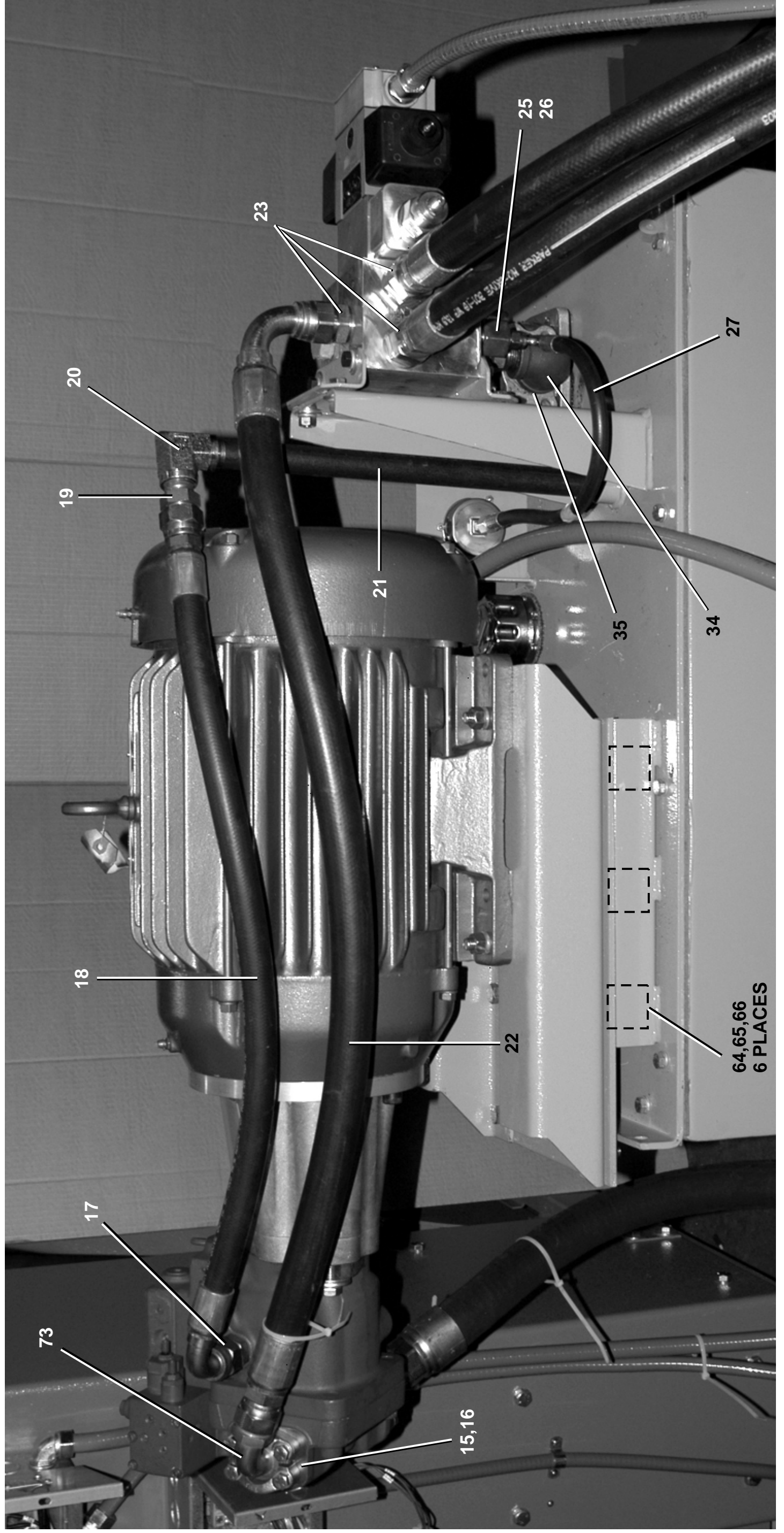
Hydraulic Tank M7V4840C

BMP050035/2005105V
(Sheet 3 of 6)



Pellerin Milnor Corporation
P. O. Box 400, Kenner, LA 70063-0400

Litho in U.S.A.



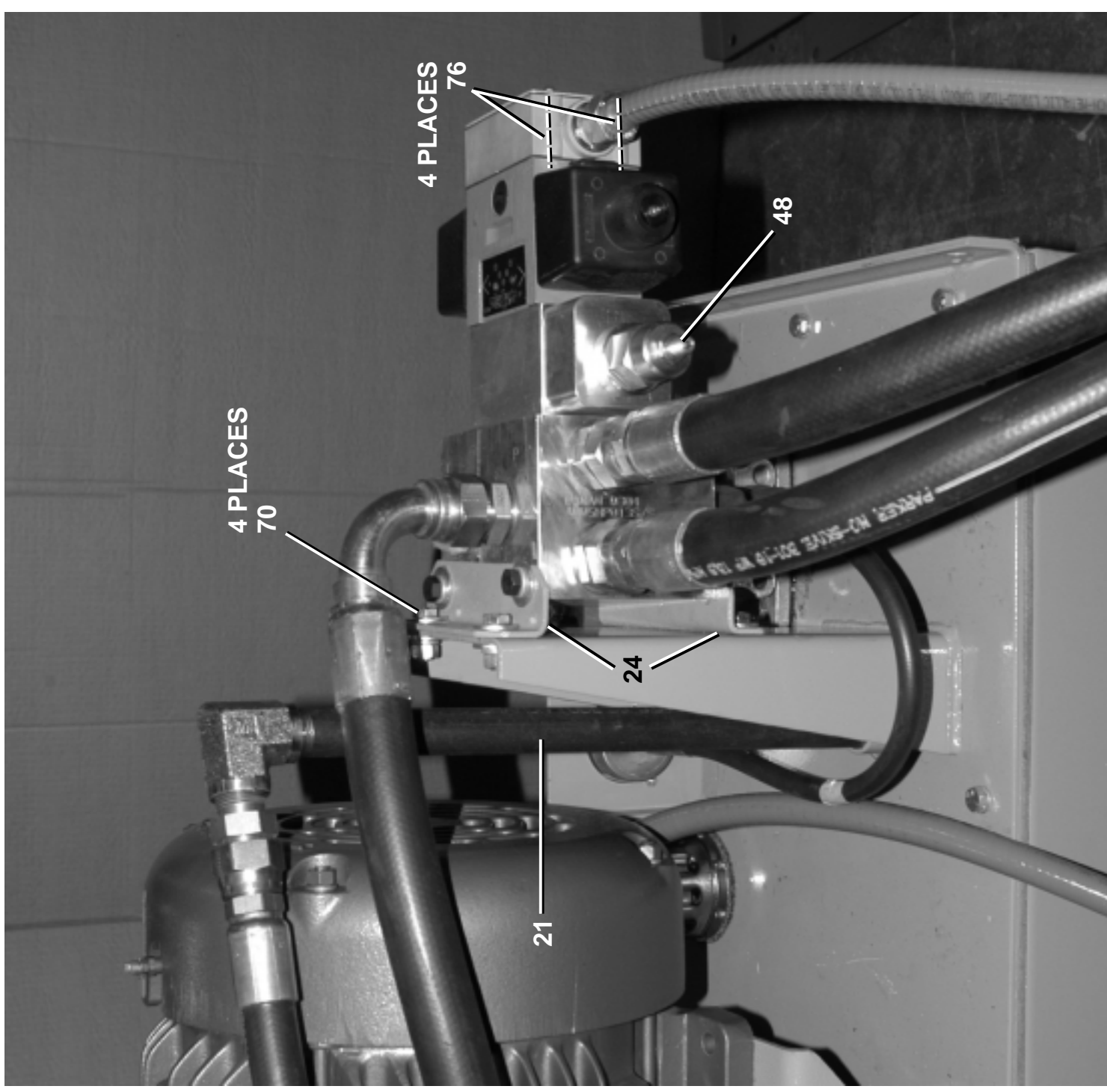
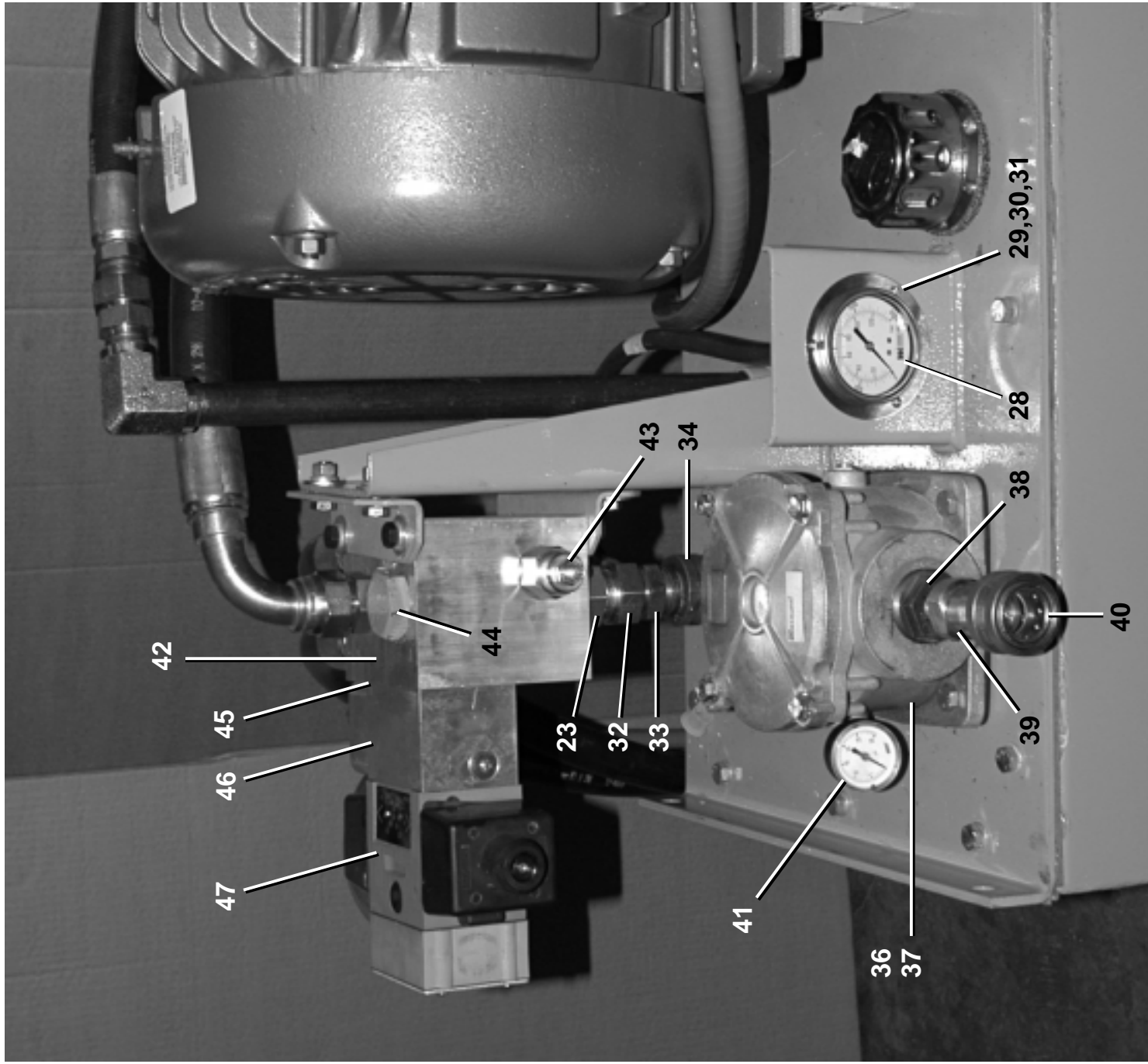
Hydraulic Tank M7V4840C

BMP050035/2005105V
(Sheet 4 of 6)



Pellerin Milnor Corporation
P. O. Box 400, Kenner, LA 70063-0400

Litho in U.S.A.



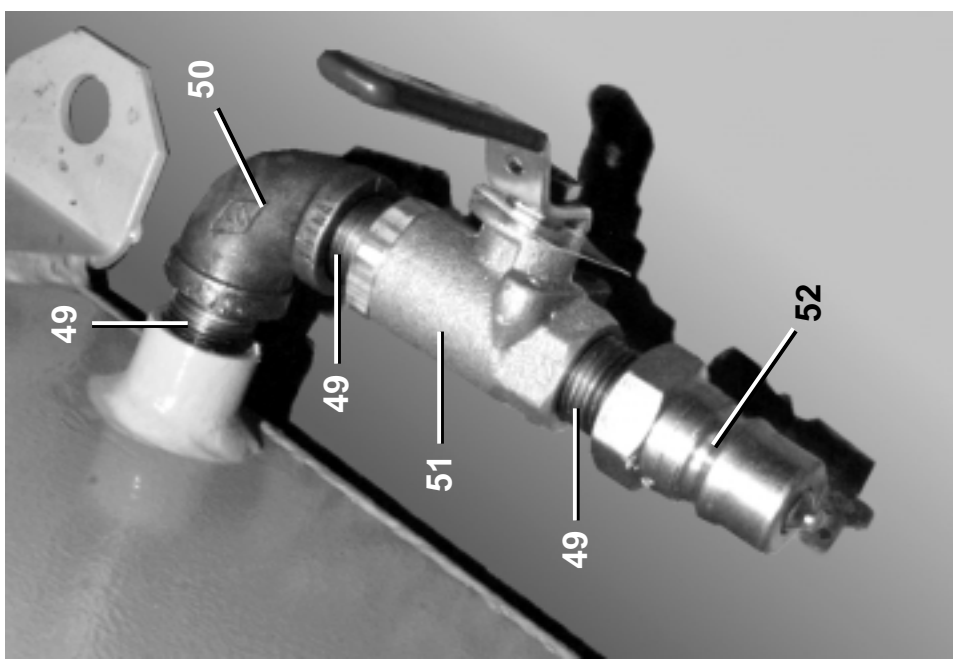
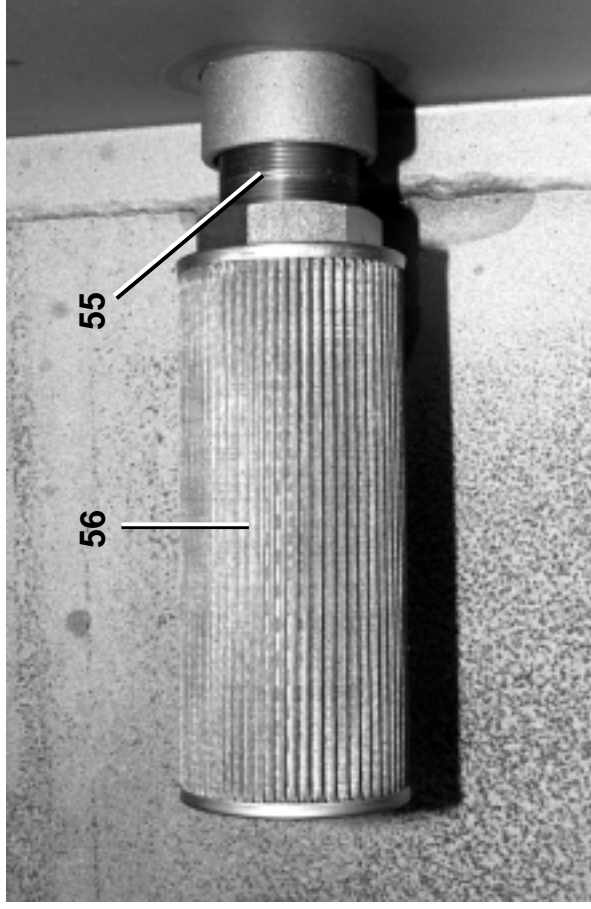
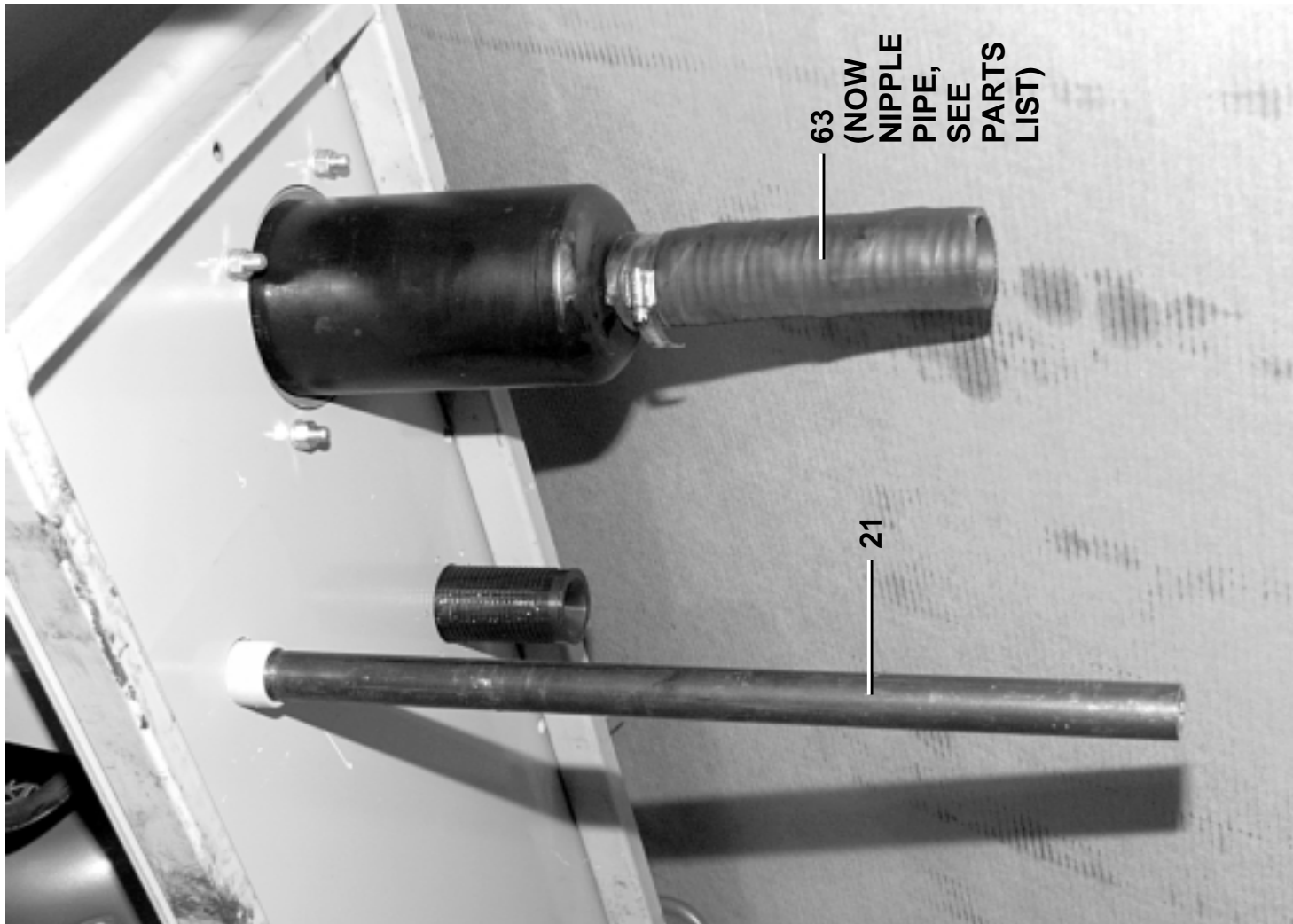
Hydraulic Tank
M7V4840C

BMP050035/2005105V
 (Sheet 5 of 6)



Pellerin Milnor Corporation
 P. O. Box 400, Kenner, LA 70063-0400

Litho in U.S.A.





Pellerin Milnor Corporation
P. O. Box 400, Kenner, LA 70063-0400

Litho in U.S.A.

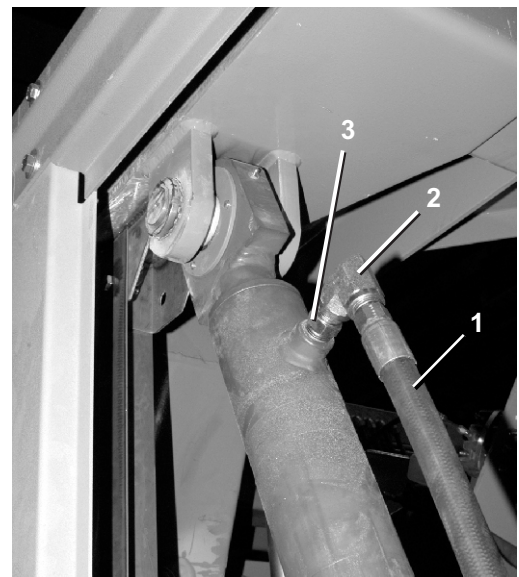
Used In	Item	Part Number	Description	Comments
	A	AHT17000A	4840M7=HYDR POWER UNIT UNIVOLT	
			ASSEMBLIES-----	
			COMPONENTS-----	
all	1	W7 10225	WLMT=OIL RESEVOIR TOP	
all	2	W3 16523A	WLMT=HYDR TANK	
all	3	03 16532	HYDR TANK SM TOP GASKET	
all	4	03 16531	HYDR TANK LG TOP GASKET	
all	5	15K095	HXCPSCR 3/8-16UNC2AX1 GR5 ZINC	
all	6	15U255	LOCKWASHER MEDIUM 3/8 ZINCPL	
all	7	39T150ACU	15HP 4P TEFC UNIVOLT	
all	8	27E5504D	PUMP-TO-MOTOR MT.	
all	9	27E550466	PISTON PUMP-KAWASAKI=35-BAR	
all	10	27E5510	COUP.ASSY.=1+5/8"BOREX3/8KW	
all	11	27E5510B	HYTREL INSERT-MAGNA#M370H5	
all	12	27E5504E	COUP.ASSY.1"BX1/4KW #M30010008	
all	13	27E5504AB	ORING FOR (27E5504A)	
all	14	27E5504A	SUCT.SPLIT FLANGE FOR VAR.PUMP	
all	15	27E5504BA	ORING FOR (27E5504B)	
all	16	27E5504B	PRESS.SPLITFLANGE FOR VAR.PUMP	
all	17	52ZCF50L0S	TUBEFITSTR3/4X1/2"#12-8F50LOS	
all	18	60EH50C28A	ASSY=HYD HOSE 3/4"X28"LG	
all	19	52ZC0P001	TUBEFITSTR3/4"#12-FLO-S	
all	20	52JYOPRC06	ELB90 3/4FPT #5504-12-12	
all	21	5N0P16AF42	NPT NIP 3/4X16 TBE BLKSTL SK40	
all	22	60EH80C36K	ASSY=HYDRAULIC HOSE 1"X36"LG	
all	23	52XY0KR050	STRDPT 3/4MX1"MU#6400-16-12-0	
all	24	07 10241	PRESSURE MANIFOLD MTG ANGLE	
all	25	52ZC00S003	TUBEFIT STRTHDCN3/4"#12F50L0-S	
all	26	52ZL00S006	TUBEFITENDRED3/4TX1/4T FACESL	
all	27	60EH21C18A	ASSY=HYDRAULIC HOSE 1/4X18 LG	
all	28	30N125G	GAUGE 0-2000PSI#BAR 1 1/4 BACK	
all	29	15U102	LOCKWASHER MEDIUM #6 SS18-8	
all	30	15G075	HEX MACH SCREW NUT 6-32UNC2 S	
all	31	15N050	RDMACSCR 6-32UNC2X1/2 SS18-8	
all	32	52XY1AP012	STRADAPT1"WORXFS#6402-16-16-0	
all	33	52XY1AP010	STRADPT 1"MXMJIC #2404-16-16	
all	34	5SL1EMFA1A	NPT ELBOW 90DEG 1.25X1" BLKMAL	
all	35	5N1ECLSF42	NPT NIP 1.25XCLS TBE BLKSTLS40	
all	36	27E7106A	FILTER ELEMENT-REPLACEMENT	

Used In	Item	Part Number	Description	Comments
all	37	27E7106	IN-LINE RETURN FILTER	
all	38	5SB1E0KMFO	NPTHEXBUSH 1.25X1/2BLKMAL 150#	
all	39	5N0KCLSF42	NPT NIP 1/2XCLS TBE BLKSTL S40	
all	40	52XY0KP00X	1/2"QUICK DISCONN.FEM#H4-62	
all	41	27E7103A	GAUGE=WIKA 1/8NPT(ON 27E7103)	
all	42	27E5506E	DAMAN MANIFOLD #AD05HP013S/S	
all	43	27E5506F	SUN HYD. CARTRIDGE #RDFALAN	
all	44	52PY1AR001	HEX PLUG 1"OR #6408-16-0	
all	45	96DH490D	RETAINER/SEAL,SUN#990120009	
all	46	96DH490B	BODY, SUN #DJD	
all	47	96RH71E37	DIRECTIONAL CONT. VLV.D05-NG10	
all	48	96DH490C	CARTRIDGE, SUN #NCFB-LCN	
all	49	5N0KCLSF42	NPT NIP 1/2XCLS TBE BLKSTL S40	
all	50	5SLOKMFA	NPT ELBOW 90DEG 1/2" BLKMAL 15	
all	51	96D034	BALLVALVE 1/2" WATTS #6400-SS	
all	52	52XY0KP00Y	1/2"QUICK DISCONN.MALE #H4-63	
all	53	60EH86C22	ASSY=HYDRALIC HOSE 1.5X22	
all	54	5SL2AMFA1K	NPT ELB 90DEG 2X1.5 BLKMAL 150#	
all	55	5N2ACLSB42	NPT NIP 2XCLS TBE BLKSTL SK40	
all	56	27E7108	SUCTION STRAINER 2" PORT	
all	57	02 18618	COVER=BEARHOUSE CAD+\$18 SU	
all	58	02 18105A	HYD TANK COVER GASKET	
all	59	15U300	LOKWASHER REGULAR 1/2 ZINC PLT	
all	60	15K145	HXCAPSCR 1/2-13UNC2AX3/4 GR5 P	
all	61	27E7301	SIGHTGAUGE-FLUID:STAUFF#SNA-2T	
all	62	27E7201	FILLER-BREATH-FILT.LHA#ABB-40N	
all	63	5N1K07AF42	NPT NIP 1.5X7 TBE BLKSTL SK40	
all	64	17N070AP	RETAIN NUT#S10222-27	
all	65	15K171B	HEXCAPSCR 1/2-13X1+3/4 GR8 ZIN	
all	66	15U300	LOKWASHER REGULAR 1/2 ZINC PLT	
all	67	15K147	HXCAPSCR 1/2-13UNC2X1 GR5 ZINC	
all	68	15U300	LOKWASHER REGULAR 1/2 ZINC PLT	
all	69	15G230	HXNUT 1/2-13UNC2B SAE ZINC GR2	
all	70	15G198	HXFLGNUT 3/8-16 ZINC	
all	71	15K049F	SOKCAPSCR 1/4-20X4 BLK GR8	
all	72	5SP0CGFSS	NPT PLUG 1/8 SQ SOLID GALSTL	
all	73	52JY1AR013	EL90COD61 1"MUJFLG#1704-16-16	

Parts List—Hydraulic Tank
Find the correct assembly first, then find the needed components. The item letters (A, B, C, etc.) assigned to assemblies are referred to in the "Used In" column to identify which components belong to an assembly. The item numbers (1, 2, 3, etc.) assigned to components relate the parts list to the illustration.

Hydraulic Hoses & Piping

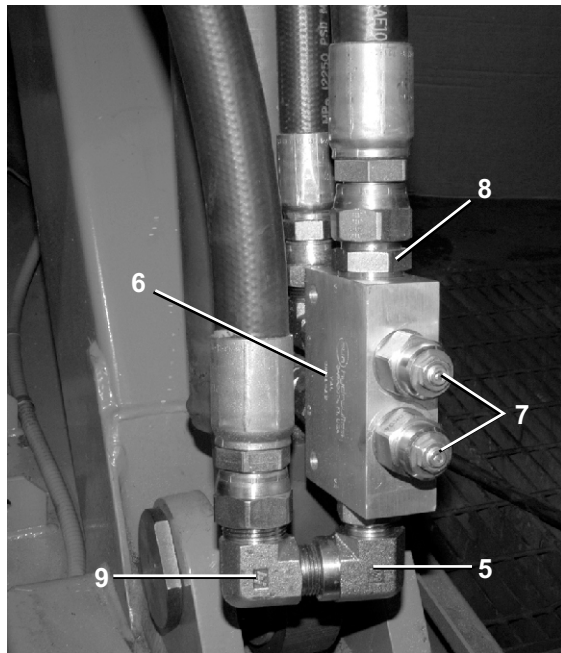
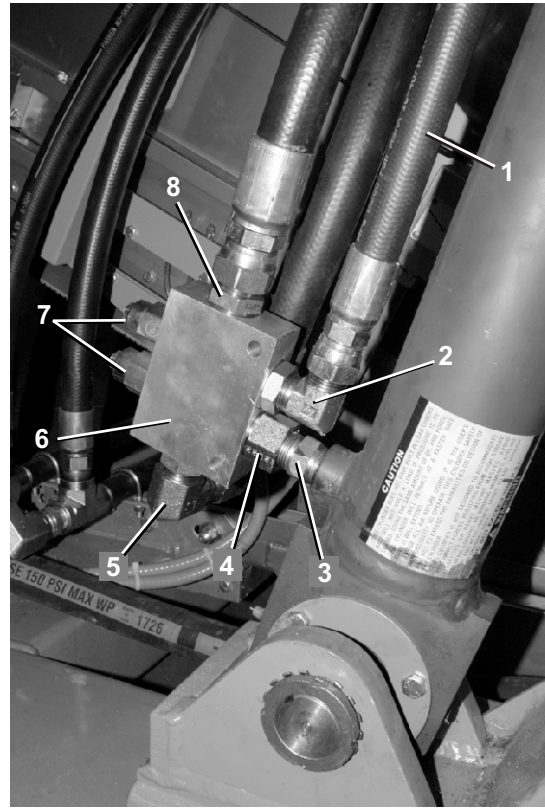
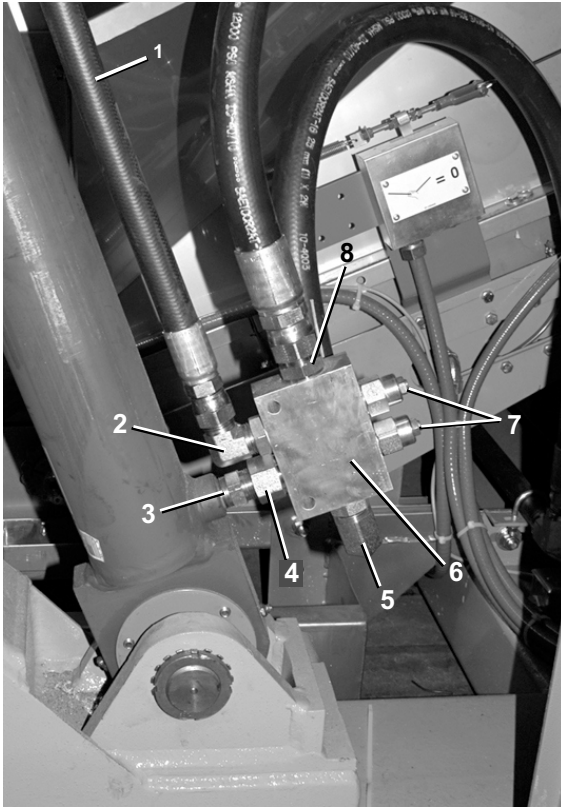
M7V4840C, M7V4836C



TYPICAL UPPER CYLINDER

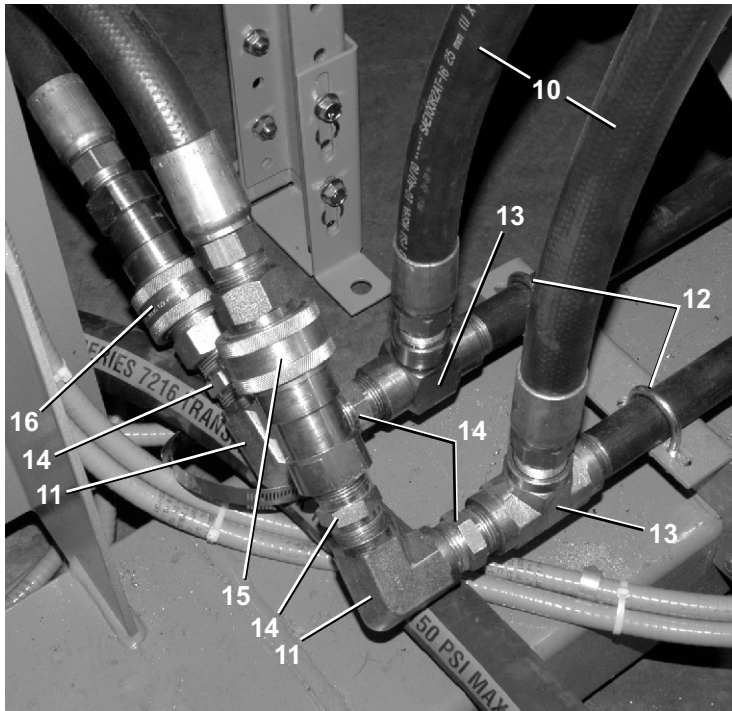
Hydraulic Hoses & Piping

M7V4840C, M7V4836C

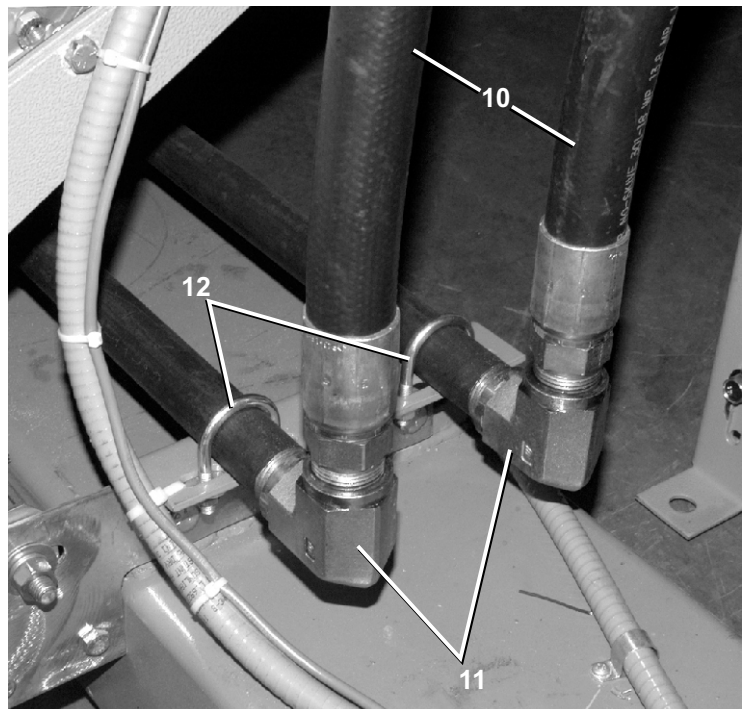


Hydraulic Hoses & Piping

M7V4840C, M7V4836C



LEFT SIDE



RIGHT SIDE

Hydraulic Hoses & Piping

M7V4840C, M7V4836C

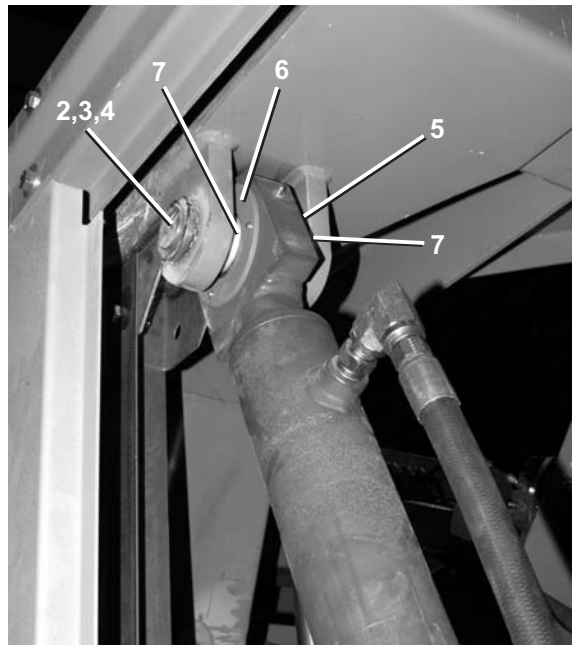
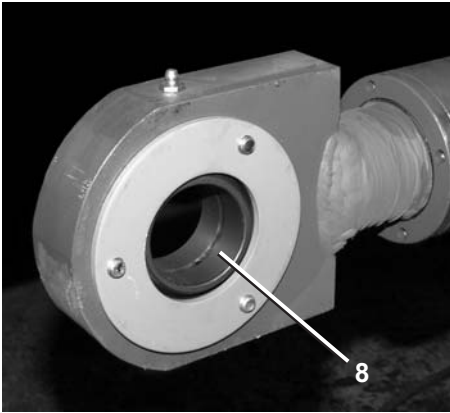
Parts List—XX

Find the correct assembly first, then find the needed components. The item letters (A, B, C, etc.) assigned to assemblies are referred to in the "Used In" column to identify which components belong to an assembly. The item numbers (1, 2, 3, etc.) assigned to components relate the parts list to the illustration.

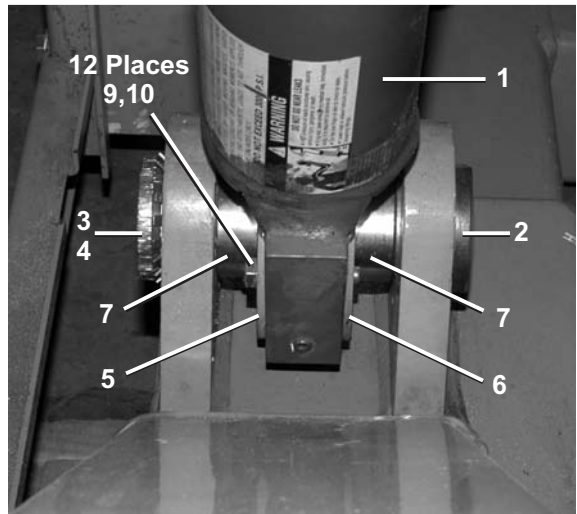
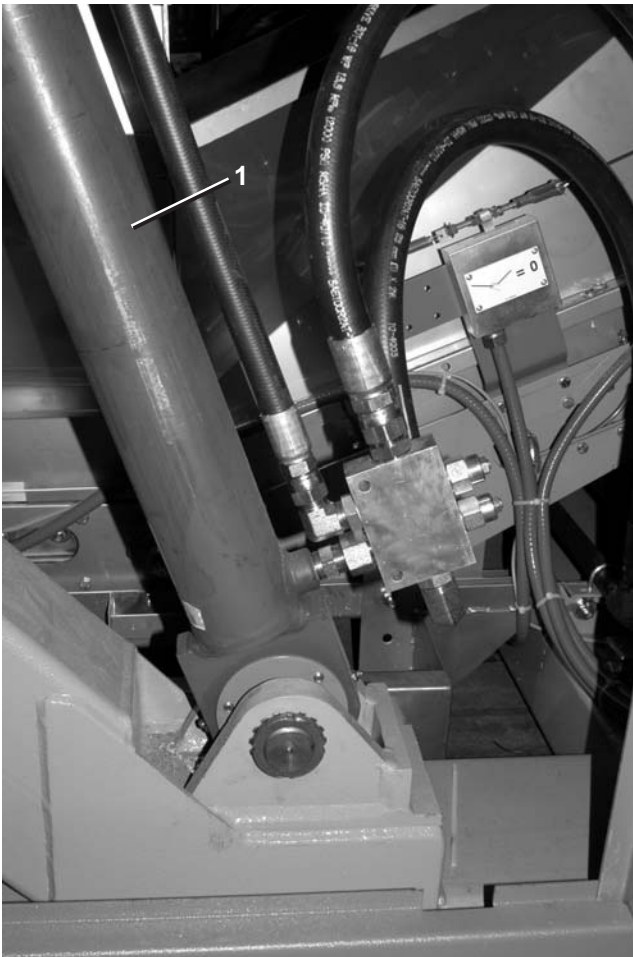
Used In	Item	Part Number	Description	Comments
-----ASSEMBLIES-----				
	A	AHT17000	HYDR HOSES&PIPING ASSEM 48M	
-----COMPONENTS-----				
all	1	60EH50C57A	HYD.HOSE 3/4+MPTXFJIC=57"HOSE	
all	2	52JY0PRC06	ELB90 3/4FPT #5504-12-12	
all	3	52LY0PR002	HEXPIPNI 3/4X3/4 #5404-12-12	
all	4	52XY0KR045	STRDPT 3/4M0RXF #6405-12-12-0	
all	5	52JY0PR008	ELB.3/4MORXF #6805-12-12NWO	
all	6	96DH472	COUNTERBALANCE VALVE-SUN BODY	
all	7	96DH472A	CARTRIDGE, COUNTERBALANCE VLV.	
all	8	52XY0KR050	STRDPT 3/4MX1"MJ#6400-16-12-0	
all	9	52JY0PR010	ELB 3/4M X1"MJIC #2501-16-12	
all	10	60EH80C56A	ASSY=HYDRAULIC HOSE 1"X56"LG	
all	11	52JY1AR006	ELBOW 90DEG 1" FEM #5504-16	
all	12	27A031	U-BOLT 1"PIPE 5/16-18X2+3/16LG	
all	13	52VY1AR006	TEE 1"FP #5605-16-16-16	
all	14	52LY1AR003	HEXPIPNI 1"=#5404-16-16	
all	15	52XY1AP001	1"QUICKDISCONNECT#H8-62COUPLER	
all	16	52XY1AP002	1"QUICKDISCONNECT #H8-63NIPPLE	
all	17	5N1A56AF82	NPT NIP 1X56 TBE BLKSTL SK80	

Hydraulic Tilt Cylinders

M9V4232, MXS4232, M7V4836, M9V4840



Typical Hydraulic Tilt Cylinder



Hydraulic Tilt Cylinders

M9V4232, MXS4232, M7V4836, M9V4840

Parts List—Hydraulic Tilt Cylinders Find the correct assembly first, then find the needed components. The item letters (A, B, C, etc.) assigned to assemblies are referred to in the "Used In" column to identify which components belong to an assembly. The item numbers (1, 2, 3, etc.) assigned to components relate the parts list to the illustration.				
Used In	Item	Part Number	Description	Comments
-----ASSEMBLIES-----				
	A	GHT17010	ASSY=4840M HYDRAULICS	M7V4836_, M7V4840_, M9S4840_
	B	GHT16000	HYD.MOTOR&PUMP ASSY 4232 M7E	M9V4232_, MXS4232_
-----COMPONENTS-----				
A	1	27E163A56A	HYD.CYL.3.25"X2.5"X56"STK.	
B	1	27E1647A64	HYD.CYL.2-STAGE 64"STROKE	
all	2	X3 65141	BOLT=2.00 SFTDIA X 5.25L HYD	
all	3	56AHN09	N09 BEARING LOCKNUT	
all	4	56AHW09	W09 BEARING LOCKWASHER	
all	5	03 65142	WASH=HYD4.75ODX2.62IDW/HOLES	
all	6	X3 65142A	WASH=HYD4.75ODX2.62IDW/TAP	
all	7	X3 65145	SPCR=HYDCYL MNT2"BALBUSH SM	
all	8	54A705A	SPHERICAL PLAIN BEARING=2"ROLLBRG#B32-L	
all	9	15K120	HXCAPSCR 3/8-16UNC2AX2 GR5 ZIN	
all	10	15U255	LOCKWASHER MEDIUM 3/8 ZINCP	

Assuring Proper Counterbalance Valve Operation-Hydraulic Tilting Washer-Extractors and Centrifugal Extractors

Various conditions, such as a non-functioning or misadjusted limit switch, a seized pivot ball bushing or, a counterbalance valve failure, can cause erratic or uneven up/down movement of the hydraulic tilt cylinders. This document addresses normal counterbalance valve operation and adjustment.

In most cases, it is not possible to perform counterbalance valve adjustments without entering the housing and/or reaching under the raised cylinder.

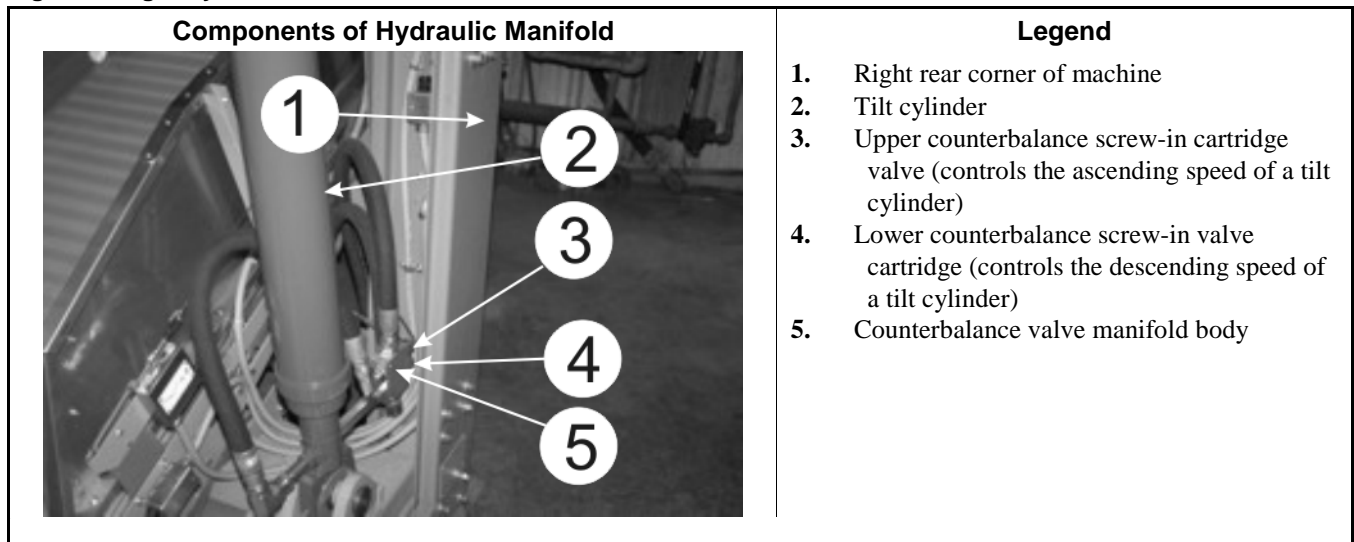


WARNING 1: Entangle and Crush Hazard—The machine shell will crush your body or limbs if it descends or falls while you are under it. The housing can descend with power off or on. Manual operation of tilting valves overrides safety interlocks. Improper operation of manual tilting valves may cause the shell to descend.

- Never operate the manual tilting with anyone under the machine.
- Use the safety stands as appropriate. If used, follow instructions in the manual.
- Read the SAFETY ALERT on use of the *access panel interlock safety bypass* switch in the service manual before setting the maintenance key switch to "Maintenance Only "
- After adjustments, return the key switch to "Safe Operation" and remove the key to a secure area before resuming normal operation.

1. Observing Tilt Cylinder Operation

Figure 1: Right Cylinder and associated Counterbalance Valves



1.1. Setup

1. Remove the left and right door side panels and identify the components shown in [Figure 1](#).
2. Set the *access panel interlock safety bypass key* switch to the "Maintenance Only" position.

1.2. Observations

Use the key pad controls, as explained in the manuals, to manually raise and lower the shell several times as described below, and verify the following proper operation.

1. Carefully move the shell from full down to full up. Verify that the cylinders move in unison and reach the top at approximately the same time.
2. Raise the shell fully and release the controls. Observe the machine for at least 3 minutes to assure that the shell does not drift down.
3. Manually lower the shell completely. Verify that the tilt cylinders move in unison and reach the bottom at approximately the same time.
4. If the cylinders exhibit any erratic movement that can be attributed to the counterbalance valves, perform the service explained below.

2. Tilt Cylinder Hydraulic Components and Functions

The hydraulic schematic provided in the service manual titled "Hydraulic Schematic " shows the counterbalance circuitry.

- 2.1. **Components**—[Figure 1](#), item 5 shows one of the two counterbalance manifolds. Each manifold has two screw-in counterbalance valve cartridges (items, 3 and 4). Referring to [Figure 2](#), each counterbalance valve cartridge has the following:

- A base nut (item 5) used to screw the valve into the manifold.
- A lock nut which must be turned slightly using an open-end wrench (item 1).
- An adjustment screw, (item 3) which must be turned with a hex key wrench.

2.2. Functions of Components

Manifold (Milnor P/N 96DH472)—Provides feedback between the two counterbalance valves

Counterbalance valve (Milnor P/N 96DH472A)—Provides the following:

- Permits unrestricted flow into a cylinder, while controlling exhaust flow from the cylinder.
- Protects against cylinder drifting down
- Reduces flow when lowering to limit speed
- Provides speed adjustment so cylinders can be made to travel in unison
- Pilot action locks machine shell from coming down if pressure is lost due to leaks

Tip: For an in-depth explanation of these components, see www.sunhydraulics.com or download Sun's virtual counterbalance valve simulation (www.e4training.com/hyd03/sitemap.htm).

3. Counterbalance Valve Adjustments

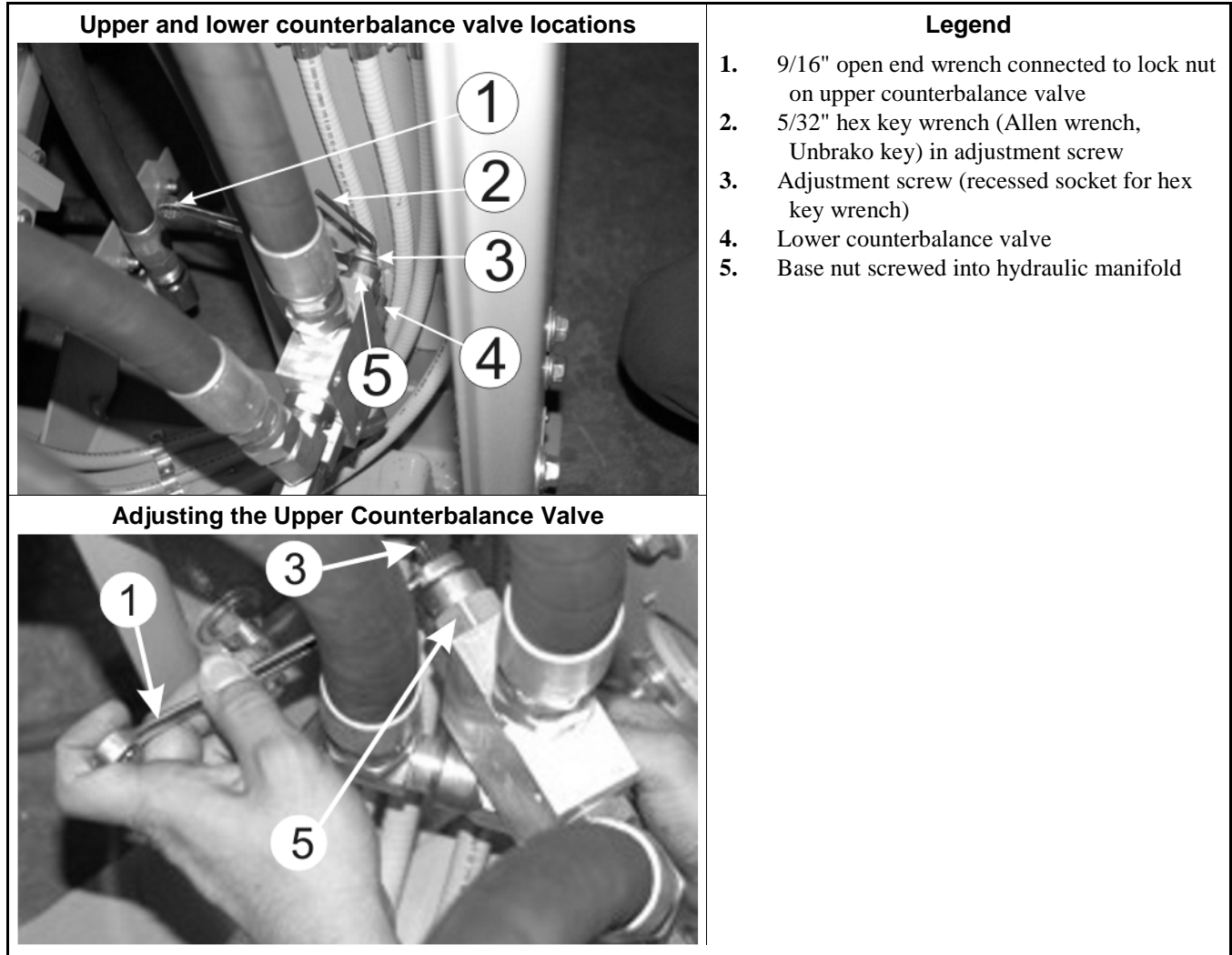
Use this procedure on all four counterbalance valves if you observe any erratic movements listed above.

- 3.1. **Coarse Adjustments**—Referring to [Figure 2](#),

1. Loosen the lock nut with a 9/16" open end wrench (item 1) .
2. Using a 5/32" hex key wrench (Allen wrench, Unbrako key), screw the adjustment nut ([Figure 2](#), item 2) in fully.

3. Back off the adjustment screws
 - a. upper valve -- one full turn (360 degrees)
 - b. lower valve -- 3/4 turn (270 degrees)
4. While holding the adjustment nut stationary, tighten the lock nut.

Figure 2: Right Side Hydraulic Manifold



3.2. Fine Adjustments—By making small adjustments of about a 1/4 of a turn to either counterbalance valve, you should be able to get the two cylinders to move up and down in unison so that both sides reach end of travel at approximately the same time. Be careful to hold the adjustment screw (Figure 2, item 3) stationary, while tightening the lock nut (Figure 2, item 1). Screw out the adjustment (Figure 2, item 3) to slow downward movement. Screw in the adjustment (Figure 2, item 3) to increase speed.

4. Return Machine to Normal Operation

Remove the tilt safety stands if they were used.

1. Manually tilt the shell down.

Assuring Proper Counterbalance Valve Operation-Hydraulic Tilting Washer-Extractors and Centrifugal Extractors

2. Replace the door side panels. Return the key switch to "safe operations" and move the key to a secure area.

— End of BIPEUM01 —

2

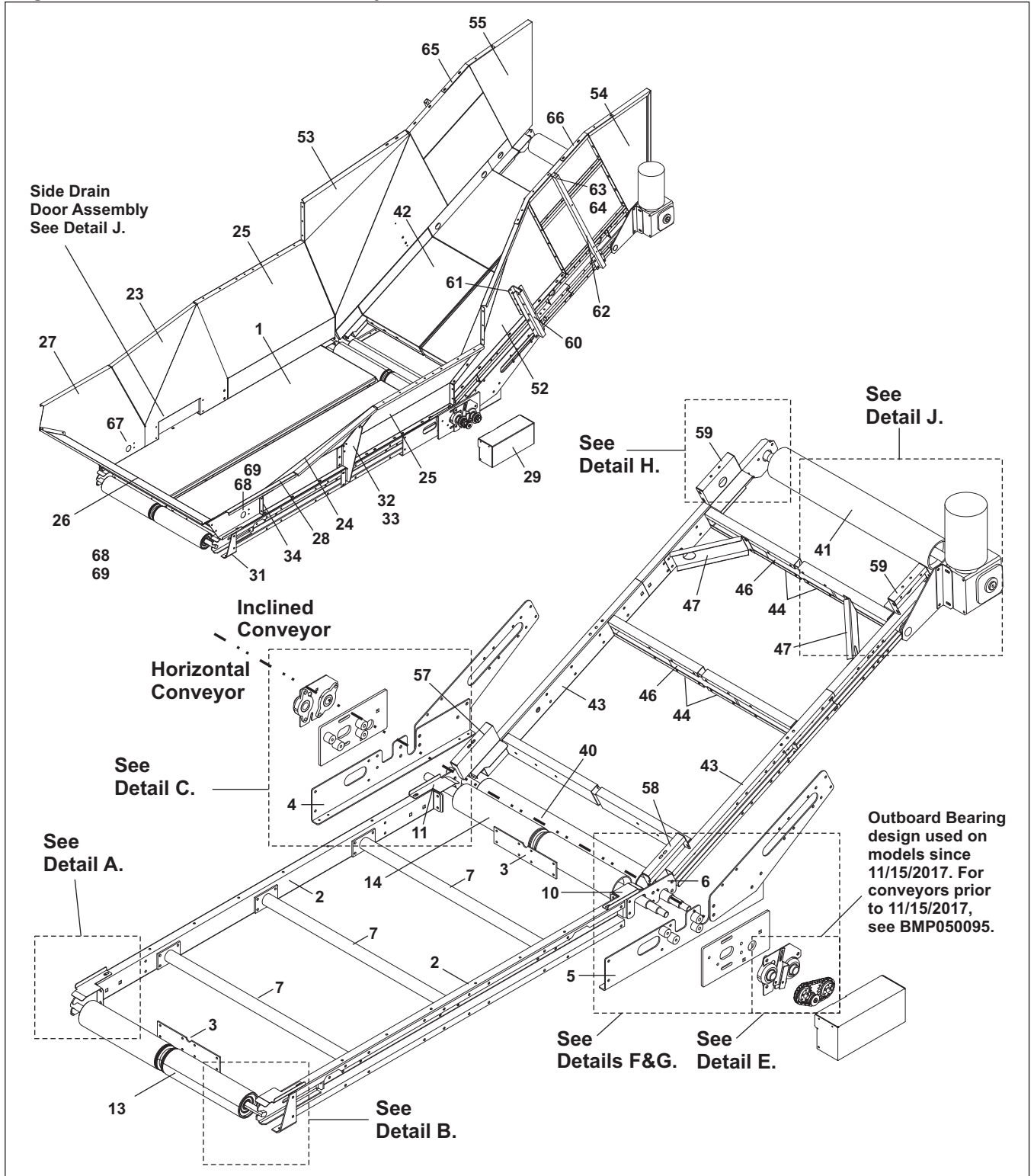
Conveyor & Reuse Tank

2.5

Extractor Conveyor with Side Drain - 25° Rear Discharge

CETE0025, CETE2425, CETE4825 for M9T4840

Figure 1: Horizontal and Inclined Conveyors Assembled



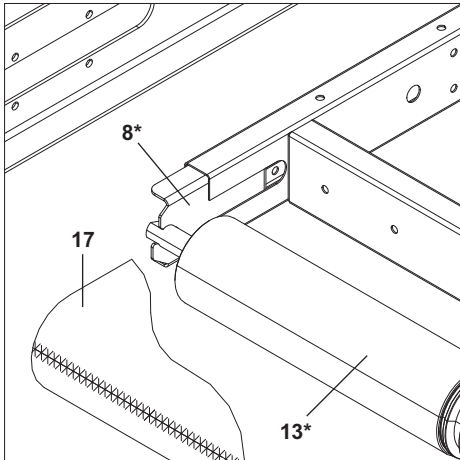
Extractor Conveyor with Side Drain - 25° Rear Discharge

CETE0025, CETE2425, CETE4825 for M9T4840

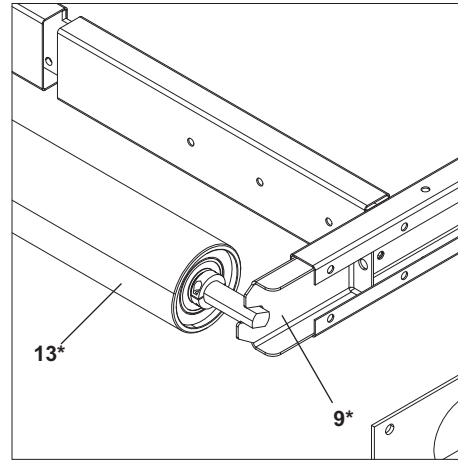
Figure 2: Horizontal Conveyor Bearing Carriers, Roller Coupler

HORIZONTAL CONVEYOR

Detail A: Idler Roller Left



Detail B: Idler Roller Right

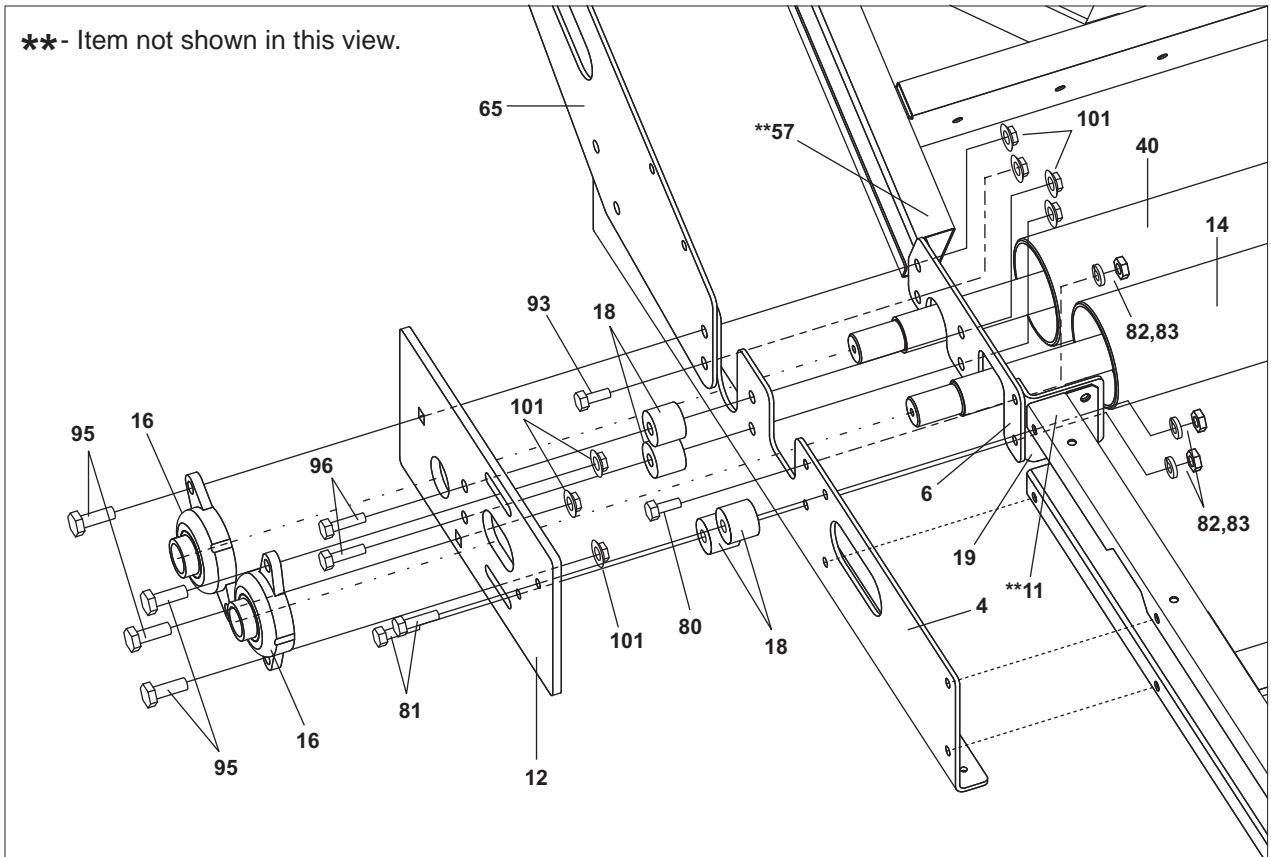


* NOTE: When replacing the Idler Rollers for machines produced before 2005, you must replace both the entire roller assembly and the roller bearing supports (items 6,7, and 11).

BELT LENGTHS:
 Horizontal – = 40"x123"
 Inclined –
 0" extension = 40"x104"
 24" extension = 40"x152"
 48" extension = 40"x202"

Detail C: Roller Coupler Non-Drive Side

** - Item not shown in this view.

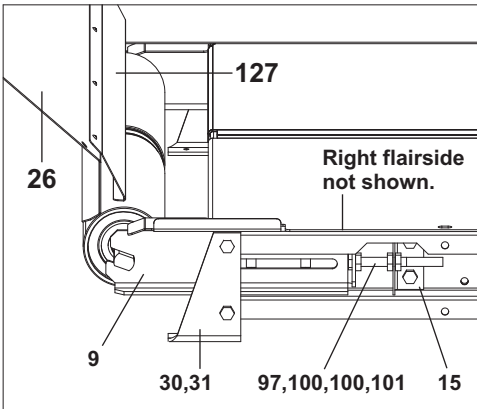


Extractor Conveyor with Side Drain - 25° Rear Discharge

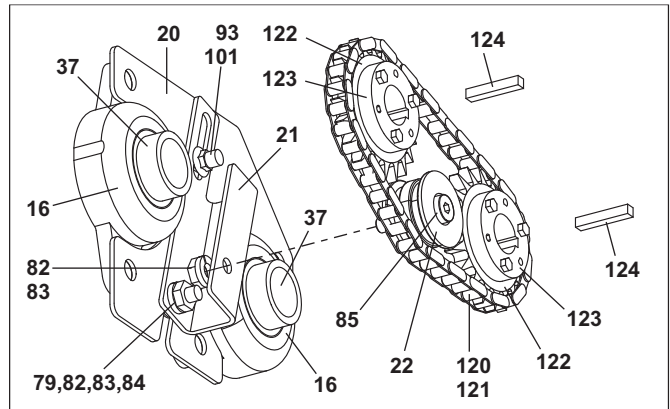
CETE0025, CETE2425, CETE4825 for M9T4840

Figure 3: Horizontal Conveyor, Roller Coupler, and Chain Drive

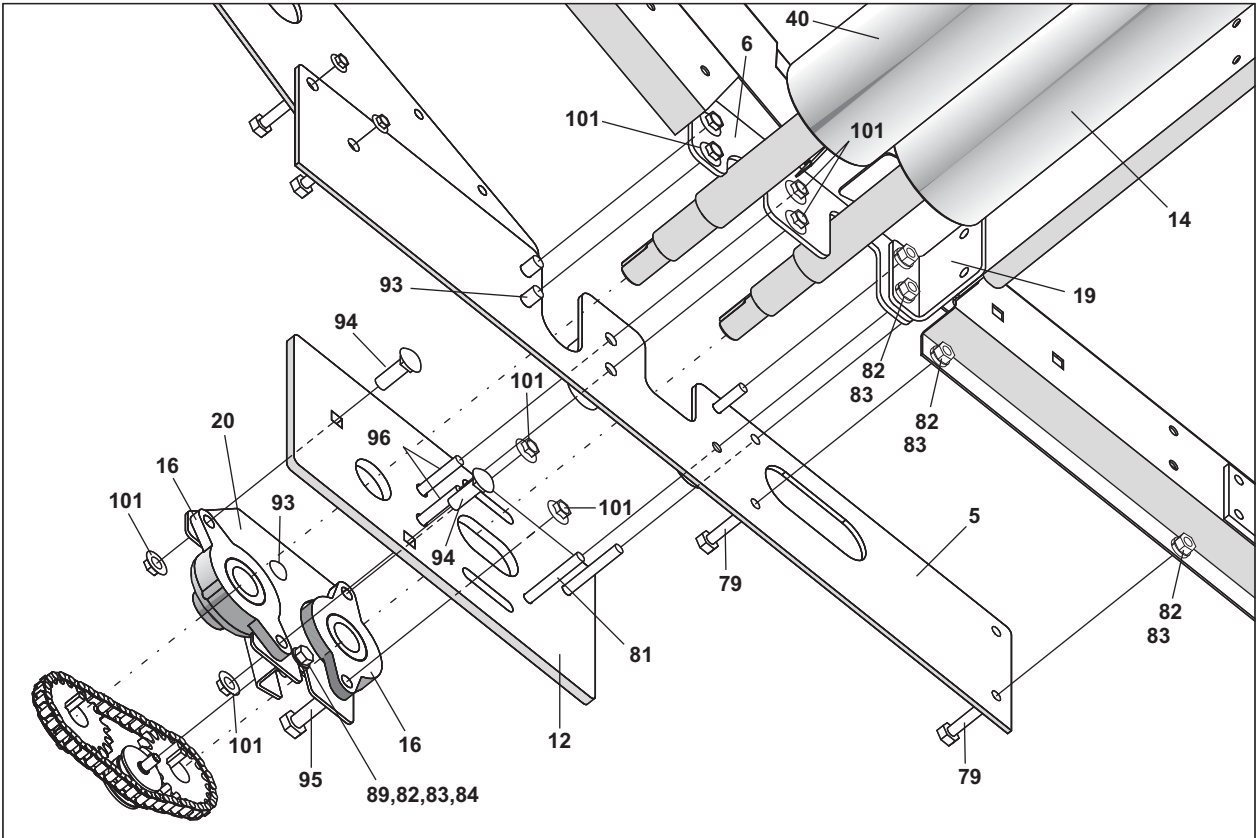
View D-D: Endgate skirt, Adjusting Bolt



Detail E: Chain Tensioning Bar and Wheel



Detail F: Roller Coupler Chain Drive Side - Bottom View

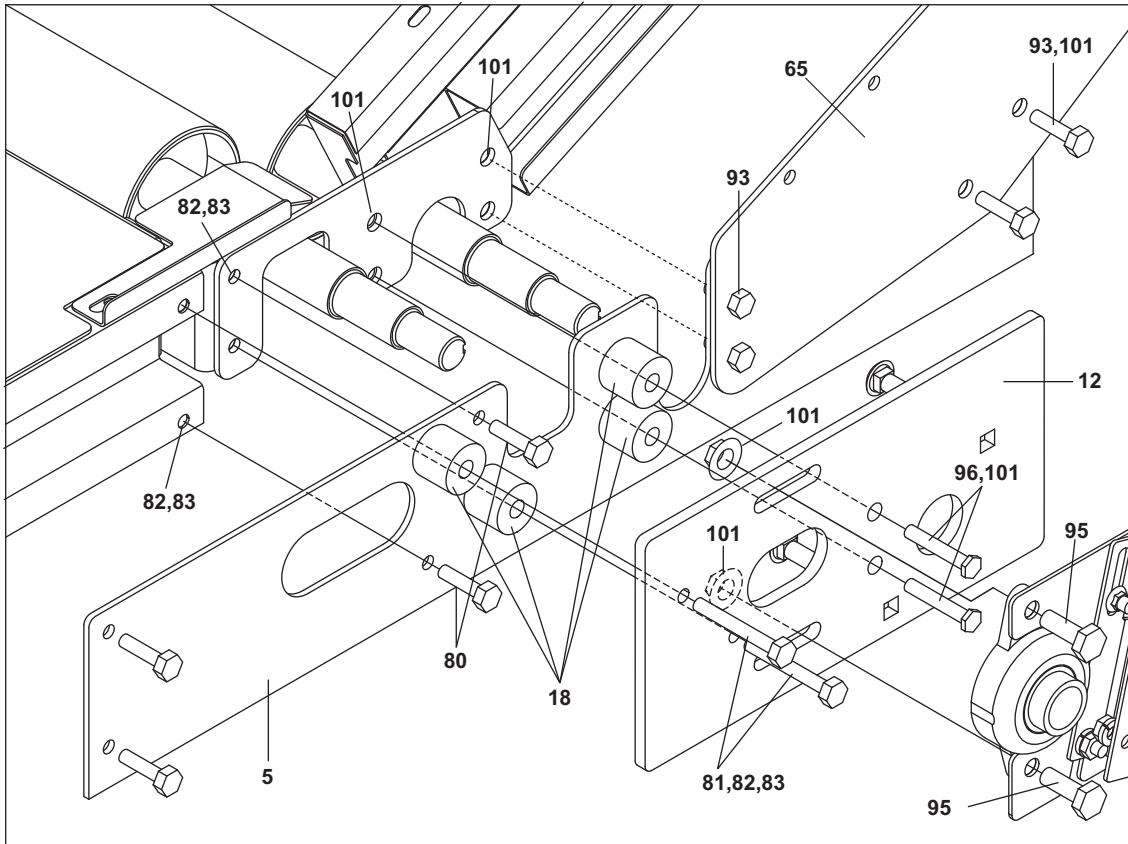


Extractor Conveyor with Side Drain - 25° Rear Discharge

CETE0025, CETE2425, CETE4825 for M9T4840

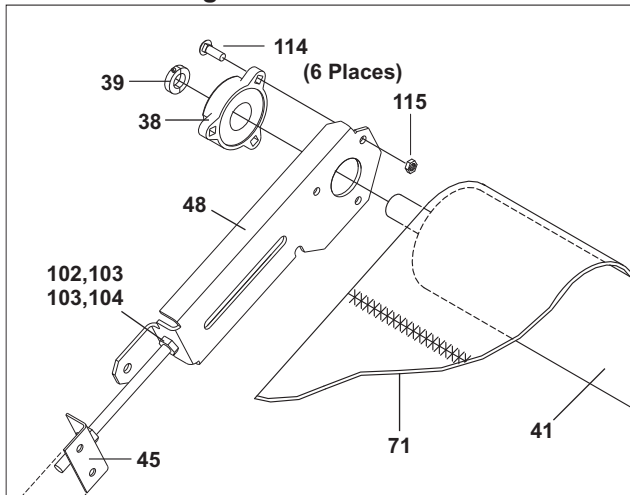
Figure 4: Roller Coupler Non-Drive Side & Bearing Carriers Inclined Conveyor

Detail G: Coupler Drive Side - Bearing Support Spacers

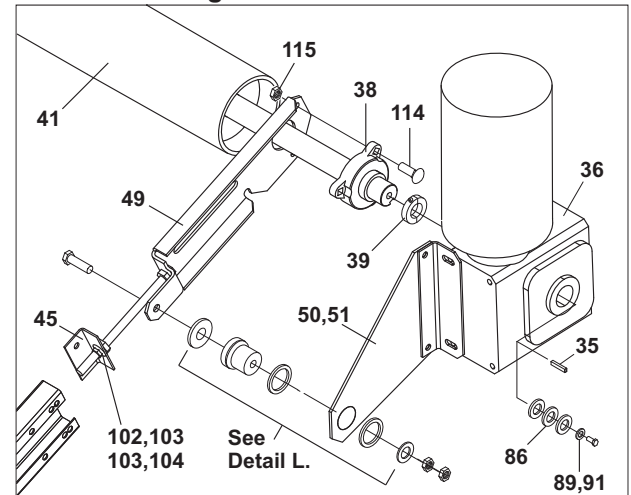


INCLINED CONVEYOR

Detail H: Bearing Carriers Idler Side



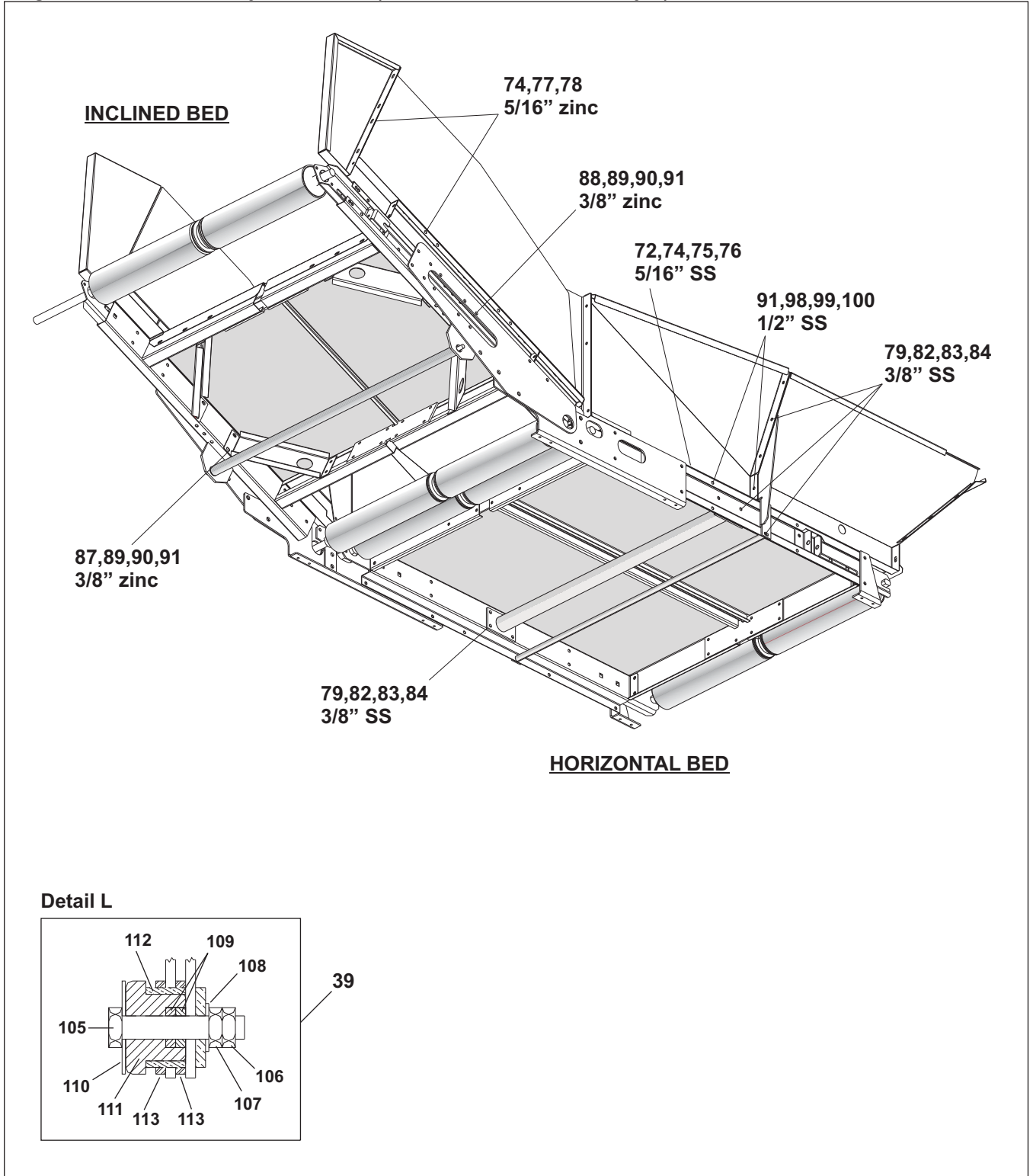
Detail J: Bearing Carriers Drive Side



Extractor Conveyor with Side Drain - 25° Rear Discharge

CETE0025, CETE2425, CETE4825 for M9T4840

Figure 6: Standard Conveyor Hardware (shown on MXS4232C conveyor)



Extractor Conveyor with Side Drain - 25° Rear Discharge

CETE0025, CETE2425, CETE4825 for M9T4840

Parts List

Find the correct assembly first, then find the needed components. The item letters (A, B, C, etc.) assigned to assemblies are referred to in the "Used In" column to identify which components belong to an assembly. The item numbers (1, 2, 3, etc.) assigned to components relate the parts list to the illustration.

Used In	Item	Part Number	Description	Comments
-----ASSEMBLIES-----				
	A	ALC50113B	CONV HORZBED-SIDE DRAIN	
	B	ALC50115C	CONV INCLINE BED-SIDE DRAIN	
-----COMPONENTS-----				
all	1	04 21814	BED HALF EXTCONV-M7V4840	
all	2	04 21815	EXTCONV SIDE FRAME-M7V4840	
all	3	04 22217S	BED CONNECTING PLATE-SS	
all	4	04 21816A	INCLINE BED MTG LF-M7V4840	
all	5	04 21816	INCLINE BED MTG RT-M7V4840	
all	6	04 24440	BED SUPP DOUBLER PL-4840M	
all	7	W4 21823	EXTCONV X-MEMBER WLMT	
all	8	04 21824	BRG CARR HORIZ BED LOAD END-LF	
all	9	04 21824A	BRG CARR HORIZ BED LOAD END-RT	
all	10	04 21828	BRNG COVER RT-COUPLER END	
all	11	04 21828A	BRNG COVER LF-COUPLER END	
all	12	04 21838	EXTCON BRNG SUPP	
all	13	ALC50114A	IDLER ROLLER 35MM BRNG SS-EXTCONV	
all	14	Y4 20832Q	COUPLER SS ROLL 4.50D X 54.00LG	
all	15	04 20808A	BEARING ADJ BRKT CONV (S/S)	
all	16	54AF1250	FLBRG 1.25" 2BOLTS SS	
all	17	54C401000A	BELT 40" X 182" GREEN V-GUIDE W/CLEAT	
all	18	04 21837A	BRNG SUPP SPACER-.53 HOLE	
all	19	04 21902	OUTBOARD BRNG PL MTG ANGLE	
all	20	04 21949	COUPLER BRNG MTG PLATE	
all	21	04 21951	CHAIN TENSION BAR	
all	22	X4 21952	CHAIN TENSIONING WHEEL	
all	23	04 21907	CONV LEFT SIDE W/ DRAIN	
all	24	04 21908	CONV RIGHT SIDE	
all	25	04 21909	CONV SIDE 24"-30DEG-M9T4840	
all	26	04 21903	ENDGATE-EXTCONV-M9T4840	
all	27	04 21905	CONV SIDE 19"X44DEG LF-M9T4840	
all	28	04 21905A	CONV SIDE 19"X44DEG RT-M9T4840	
all	29	04 21845A	EXTCONV OUTBOARD SPROCKET COVER	
all	30	04 21826	CONV SUPPORT BRKT REAR-LF	
all	31	04 21826A	CONV SUPPORT BRKT REAR-RT	
all	32	04 21917A	FLAIRSIDE SUPPORT M9T4840-LF	
all	33	04 21917	FLAIRSIDE SUPPORT M9T4840-RT	
all	34	04 21925	SIDE SUPPORT BRKT LF-M9T4840	
all	34	04 21925A	SIDE SUPPORT BRKT RT-M9T4840	

Extractor Conveyor with Side Drain - 25° Rear Discharge

CETE0025, CETE2425, CETE4825 for M9T4840

Parts List

Find the correct assembly first, then find the needed components. The item letters (A, B, C, etc.) assigned to assemblies are referred to in the "Used In" column to identify which components belong to an assembly. The item numbers (1, 2, 3, etc.) assigned to components relate the parts list to the illustration.

Used In	Item	Part Number	Description	Comments
all	35	1.50E+229	MACHINE KEY .375X.312X5.50LG	
all	36	54STB32640	REDUCER 40:1 SF726-40T-B5-G	
all	37	54JH11000S	SHAFTCOLLAR SPLIT 1" STAINLESS	
all	38	54AF1437	FLGEBRG.HUBCITY 3-BOLT FB150URX1-7/16 (DURALINE#1002-07201)	
all	39	54JH11437C	SHAFTCOLLAR 1.4375 CFG #23S	
all	40	APC42006C	40W COUPLER LAGGED NO GROOVE	
all	41	APC40008	40W LAGGED ROLLER 1.44 DRIVE	
all	42	04 20804G	CONV BED 40WX28L GROOVE	
all	43	04 20802K	CONV SIDE FRAME 4"X40"LG	
all	44	04 20803A	CROSS MBR SECTION CONV (S/S)	
all	45	04 20808	BRNG ADJ BRKT CONV	
all	46	04 20809S	BED JOINER PLATE S/S	
all	47	04 20810A	CORNER BRACE CONV 4" (S/S)	
all	48	04 21839	BRNG SUPP 5.75D ROLLER-LF	
all	49	04 21839A	BRNG SUPP 5.75D ROLLER-RT	
all	50	04 21840	TORQARM 5.75D ROLLER 726:40	
all	51	04 22999	TORQARM MTG ANGLE	
all	52	04 21846F	FLAIRSIDE INCL BED RT-M9T4840	
all	53	04 21846G	FLAIRSIDE INCL BED LF-M9T4840	
all	54	04 21853B	SIDE UNLOADEND 33"HX25DEG-RT	
all	55	04 21853C	SIDE UNLOADEND 33"HX25DEG-LF	
all	57	04 22032A	SPACER BLOCK 9"LG-LF	
all	58	04 22032B	SPACER BLOCK 9"LG-RT	
all	59	04 22137	SPACER BLOCK 4"X7.94LG	
all	60	04 21848	FLAIRSIDE SUPPORT-4840M EXTCON	
all	61	04 21849	LIFTING PADEYE MTG BRKT	
all	62	04 24496	SIDE SUPPORT UNLOADEND-4840M	
all	63	04 21899	CONV SIDE SUPPORT CLAMP	
all	64	15P149	1/4-14X3/4 SCRSELFDRIL+TAP ZC	
all	65	04 21888	SIDE DISC TOP STIFFENER-RT	
all	66	04 21888A	SIDE DISC TOP STIFFENER-LF	
all	67	09RPE011	PHOTOEYE VALU-BEAM 10-30DC	
all	68	09RPE001A	REFLECTOR 3"DIA CLEAR	
all	69	03 BF2X4W	MOUNT PLT=PHOTO REFLECTOR	
all	71	54C401000E	BELT 40" X 114" V-ROUGH TOP	
all	71	54C401000F	BELT 40" X 162" ROUGH TOP	
all	71	54C401000G	BELT 40" X 210" V-ROUGH TOP	
all	72	15K052	HXCAPSCR 5/16-18UNC2AX3/4 SS18	
all	73	15K063	HXCPCSC 5/16 18X1 GR8 ZC	

Extractor Conveyor with Side Drain - 25° Rear Discharge

CETE0025, CETE2425, CETE4825 for M9T4840

Parts List

Find the correct assembly first, then find the needed components. The item letters (A, B, C, etc.) assigned to assemblies are referred to in the "Used In" column to identify which components belong to an assembly. The item numbers (1, 2, 3, etc.) assigned to components relate the parts list to the illustration.

Used In	Item	Part Number	Description	Comments
all	74	15U189	FLTWASH 9/32IDX3/40DX.063THK S	
all	75	15U205	LOCKWASHER MEDIUM 5/16" 18-8SS	
all	76	15G186	HEXNUT 5/16-18UNC2 SS18-8	
all	77	15U210	LOKWASHER MEDIUM 5/16 ZINCPL	
all	78	15G185	HXNUT 5/16-18UNC2B SAE ZINC GR	
all	79	15K096	HEXCAPSCR 3/8-16UNC2X1SS18-8	
all	80	15K100	HEXCAPSCR 3/8-16X1+1/4 SS18-8	
all	81	15K133S	HXCAPSCRW 3/8-16UNCX3" SS18-8	
all	82	15U260	LOCKWASHER MEDIUM 3/8 SS18-8	
all	83	15G206	HEXNUT 3/8-16 UNC2 SS 18-8	
all	84	15U245	FLTWASH 3/8 STD COMM 18-8 SS	
all	85	15C061S	HXSOKSTRIPBLT 1/2X1X3/8-16 18-8SS	
all	86	15U241MB	FLAT WASHER-1.50D 1+1/32ID 10G	
all	87	15K091H	HEXFLGSCR 3/8-16X3/4 ZN GRD.5	
all	88	15K095	HXCPSCR 3/8-16UNC2AX1 GR5 ZINC	
all	89	15U240	FLATWASHER(USS STD) 3/8" ZNC P	
all	90	15U255	LOCKWASHER MEDIUM 3/8 ZINCPL	
all	91	15G205	HXNUT 3/8-16UNC2B ZINC GR2	
all	92	15K145D	HXCAPSCR 1/2-13UNC2AX3/4 SS18-	
all	93	15A058	CARRSCR 1/2-13UNC2X 1+1/4 SS	
all	94	15A058B	CARRSCR 1/2-13UNC2X 1+1/2 SS	
all	95	15K112	HXCAPSCR 3/8-16X1+1/2 SS18-8	
all	96	15K196	HEXCAPSCR 1/2-13UNC2X3 18-8SS	
all	97	15K203S	HEXTAPSCR 1/2-13UNC2AX5 SS18-8	
all	98	15U285	FLATWASHER 1/2 STD COMM SS18-8	
all	99	15U310	LOKWASHER REGULAR 1/2 SS18-8	
all	100	15G225	HEXNUT 1/2-13UNC2 SS18-8	
all	101	15G225H	HEXFLGNUT 1/2-13 SERRATED 18-8	
all	102	15K205	HXCAPSCR 1/2-13UNC2AX8.5GR5 ZI	
all	103	15G230	HXNUT 1/2-13UNC2B SAE ZINC GR2	
all	104	15G222B	HEXFLGNUT 1/2-13 ZINC SERRATED	
all	105	15K144C	HEXCAPSCR 7/16-14UNC X 2.5 GR	
all	106	15G222	HXFINJAMNUT 7/16-14UNC2B ZINC	
all	107	15G222C	HEXNUT 7/16-14UNC2B ZINC GR2	
all	108	15U271	LOKWASH INTOOTH 7/16ZN	
all	109	15U312	HARD FWASH 3/4ODX33/64IDX.115	
all	110	15U202	FLATWSHR.50ID1.75OD11GA ZNC	
all	111	60B065	RUBBER MNT CTR BONDED 40 DURO	

Extractor Conveyor with Side Drain - 25° Rear Discharge

CETE0025, CETE2425, CETE4825 for M9T4840

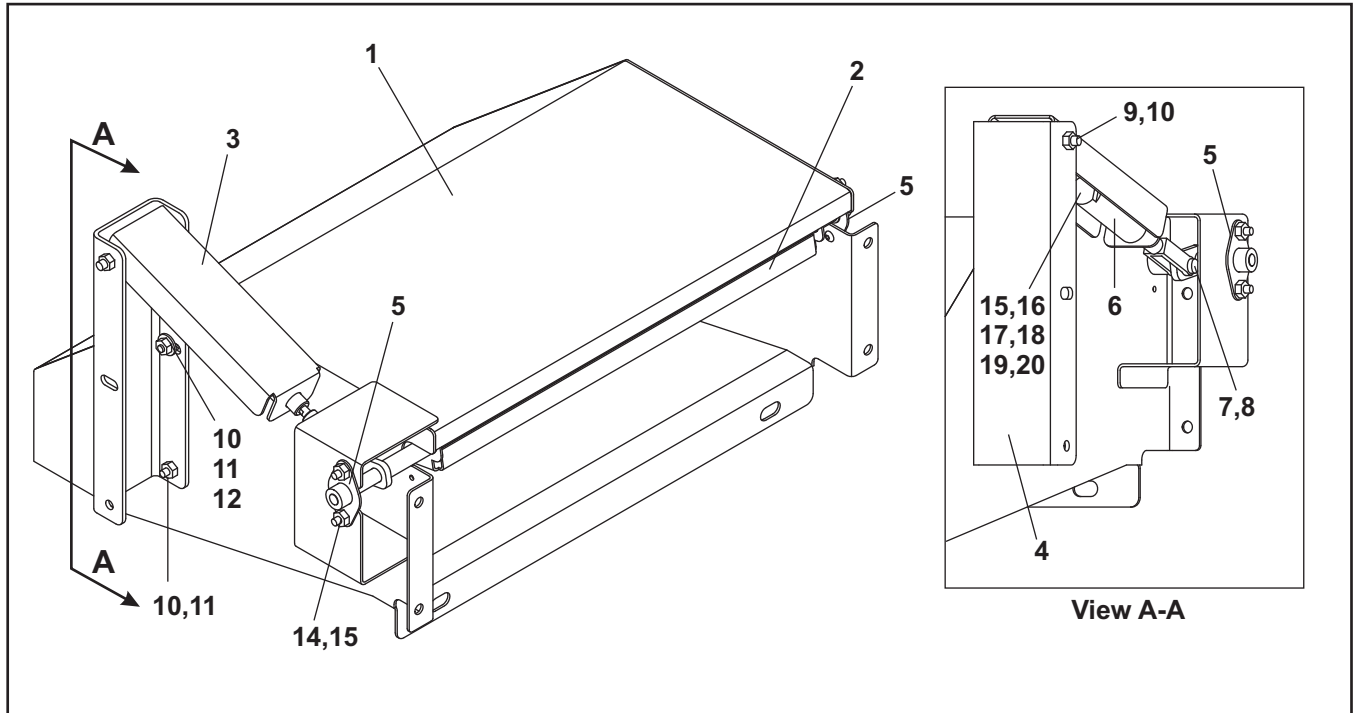
Parts List

Find the correct assembly first, then find the needed components. The item letters (A, B, C, etc.) assigned to assemblies are referred to in the "Used In" column to identify which components belong to an assembly. The item numbers (1, 2, 3, etc.) assigned to components relate the parts list to the illustration.

Used In	Item	Part Number	Description	Comments
all	112	04 20796	SLEEVE=TORQUE ARM BUSHING	
all	113	02 18571A	PISTON ROD WASHER-.25"TK	
all	114	15A011	CARBOLT 3/8-16UNC2X1 ZINC GR2	
all	115	15G218	HXLKNUT NYL 3/8-16 STL/ZNC	
all	120	54G050SS30	ROLCHN 50SS1R 30PITCH W/CONN LINK	
all	121	54G050RSS	OFFSET LINK ANSI 50SS COTTER PIN	
all	122	54N050JA13	SPRKT MARTIN #50JA13SS MTO-NO BUSH	
all	123	56Q1AJA	1.0" BUSHING M#JA-1-304SS MTO	
all	124	1.50E+198	1/4X1/4X1SQMACHKEY N0 TAPR/HD	
all	125	20C007G	THDLOCKSEAL LCT24231 RMUBL50CC	
all	126	15P180	TRDCUT-F HXHD 1/4-20UNC2X5/8 S	
all	127	04 24259	ENDGATE SKIRT-4840M CONV	

Side Drain Door Assembly

CETE0025, CETE2425, CETE4825 for M9T4840



Parts List

Find the correct assembly first, then find the needed components. The item letters (A, B, C, etc.) assigned to assemblies are referred to in the "Used In" column to identify which components belong to an assembly. The item numbers (1, 2, 3, etc.) assigned to components relate the parts list to the illustration.

Used In	Item	Part Number	Description	Comments
-----ASSEMBLIES-----				
	A	ALC50173	SIDE DRAIN DOOR ASSY-M9T4840	
-----COMPONENTS-----				
all	1	W4 21909	CONV SIDE DRAIN OUTLET WLMT	
all	2	W4 21913	CONV SIDE DRAIN DOOR WLMT	
all	3	04 21920	AIRCLY MOUNTING BRKT	
all	4	04 21916	SIDE DRAIN AIRCYL MTG BRKT	
all	5	54E002PABA	ASSY=5/16"PRESSBEARING	
all	6	27C205	AIRCYL 3/4"BORE X 1"STROKE	
all	7	17A004	ADJ YOKE END 1/4-28 XYLAN COAT	
all	8	17A004A	CLEVIS PIN 1/4"X3/4"DRILLED SS	
all	9	15K049E	HXTAPSCR 1/4-20X3.5 FULTHZC	
all	10	15G164NE	HEXLOKNUT NYL 1/4-20 UNC2A SS.	
all	11	15K033	BUTSOKCAPSCR 1/4-20X5/8 SS18-8	
all	12	15U188	FLTWASH 1/4 STD COMM SS18-8	
all	13	15K017	BUTSOKCAPSCR 10-24X1/2 SS	
all	14	15G126	HXLOCKNUT NYLON 10-24 UNC SS N	
all	15	53A031B	BODY-EL90MALE.25X1/8 #269C-42B	
all	16	60E004TE	1/4"OD X.170"ID NYL(BLK)TUBING	
all	17	53A500	SLEEVE DELRIN 1/4"OD#60PT-4	
all	18	53A059A	NUT 1/4"BR.HOLYOKE AND #61A-4	
all	19	53A501	TUBE INSERT .163"OD #63PT-4-40	
all	20	53A008B	BODYMALECON.25X.25COMP#B68A-4B	

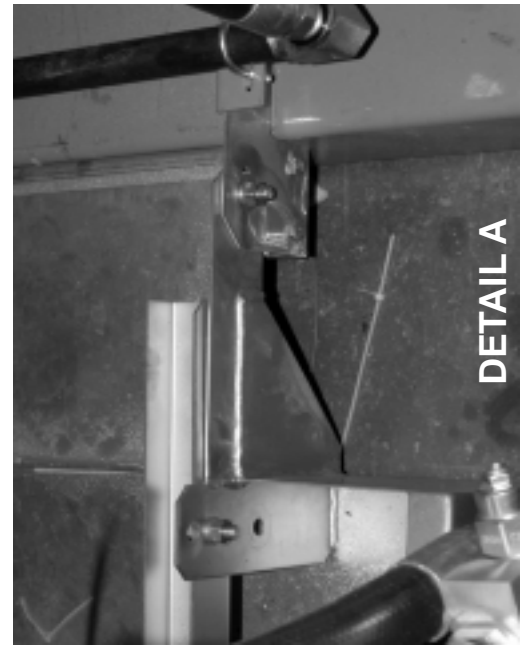
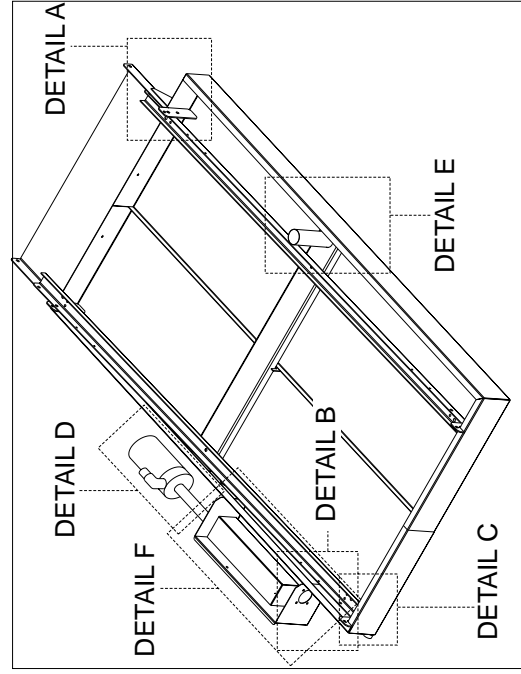
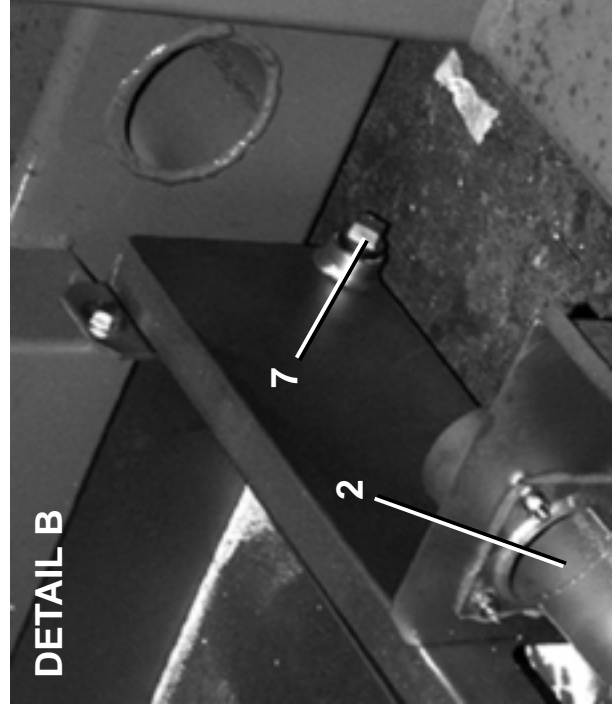
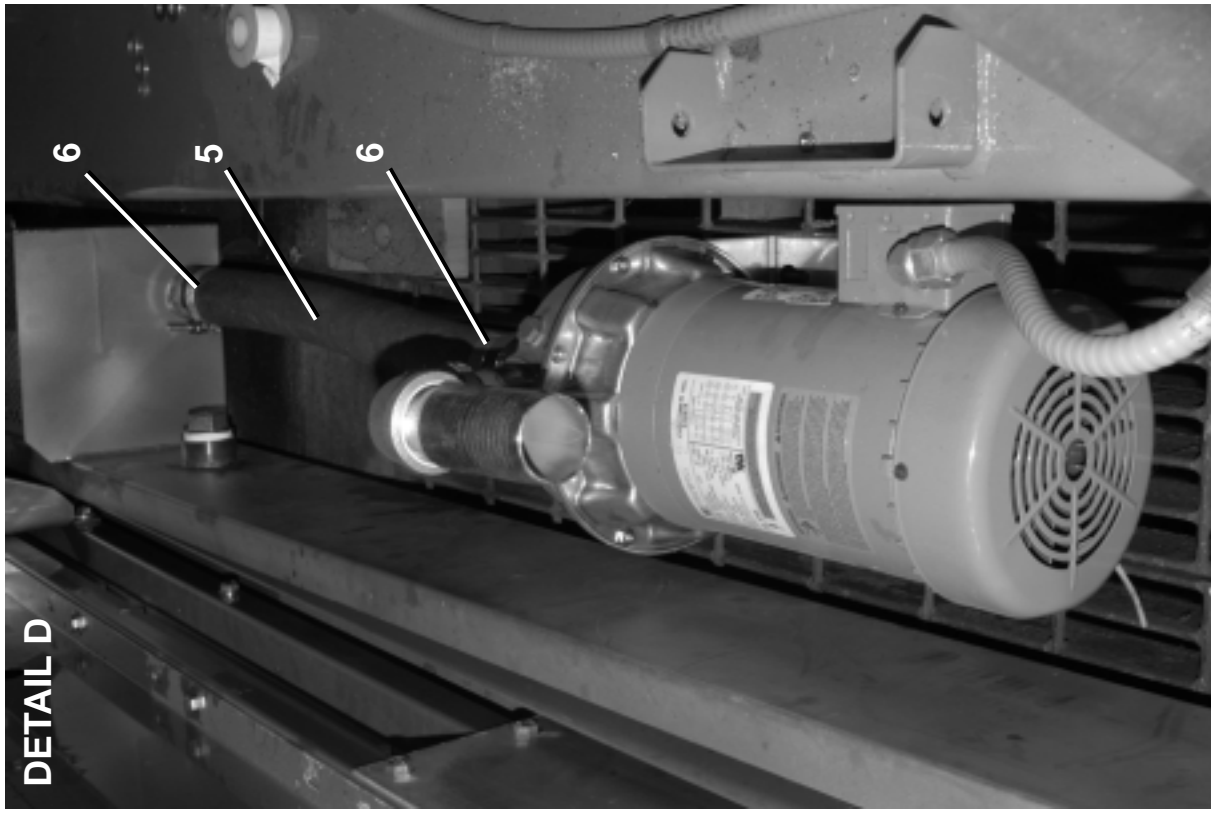
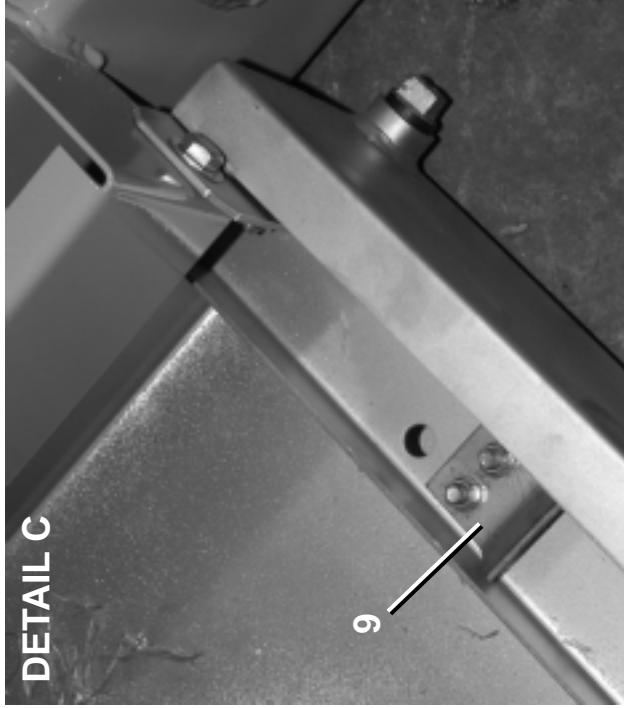
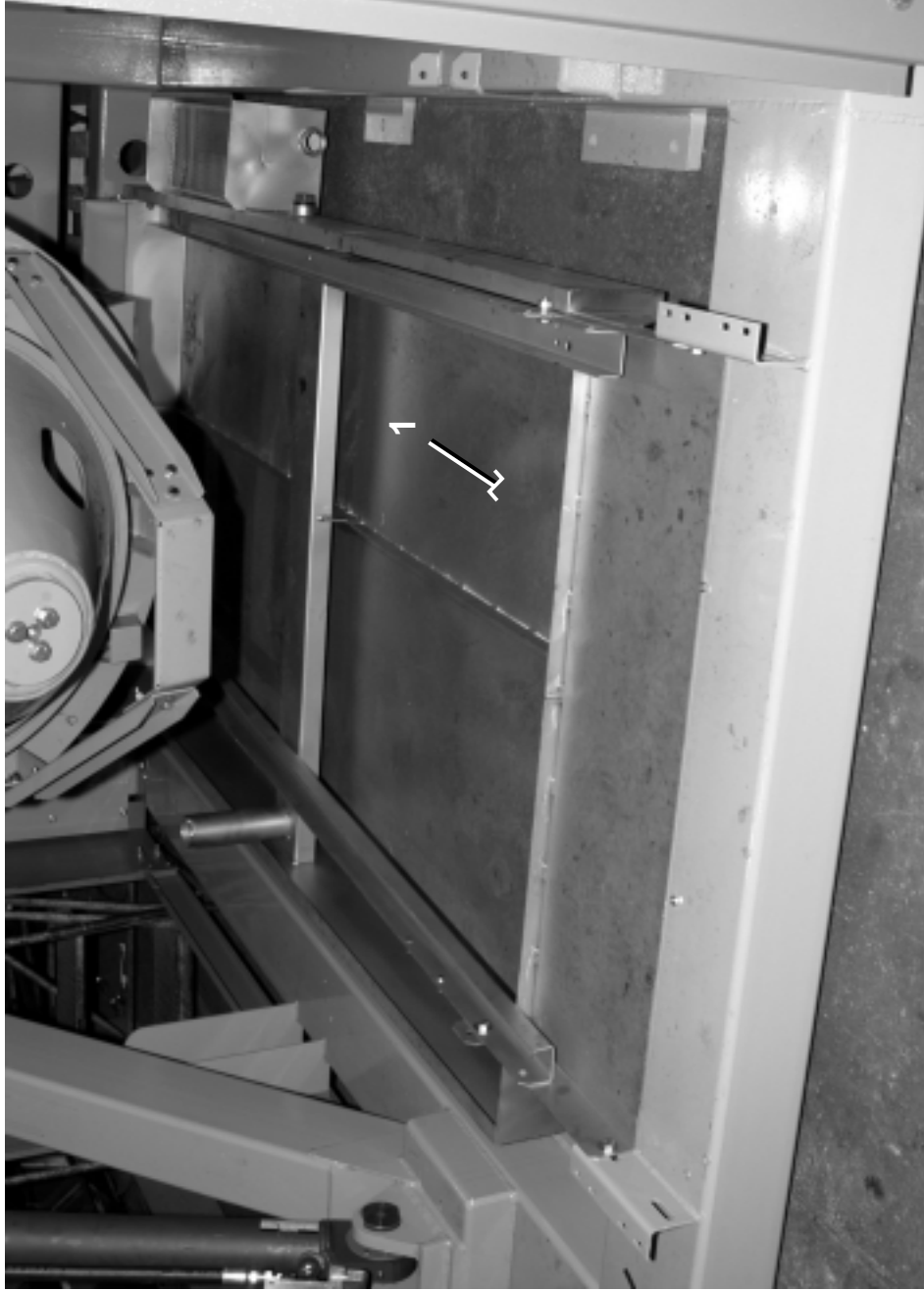
Reuse Tank & Level Switch
M7V4840C, M7V4836C

BMP050046/2005105V
 (Sheet 1 of 2)



Pellerin Milnor Corporation
 P. O. Box 400, Kenner, LA 70063-0400

Litho in U.S.A.



Reuse Tank & Level Switch

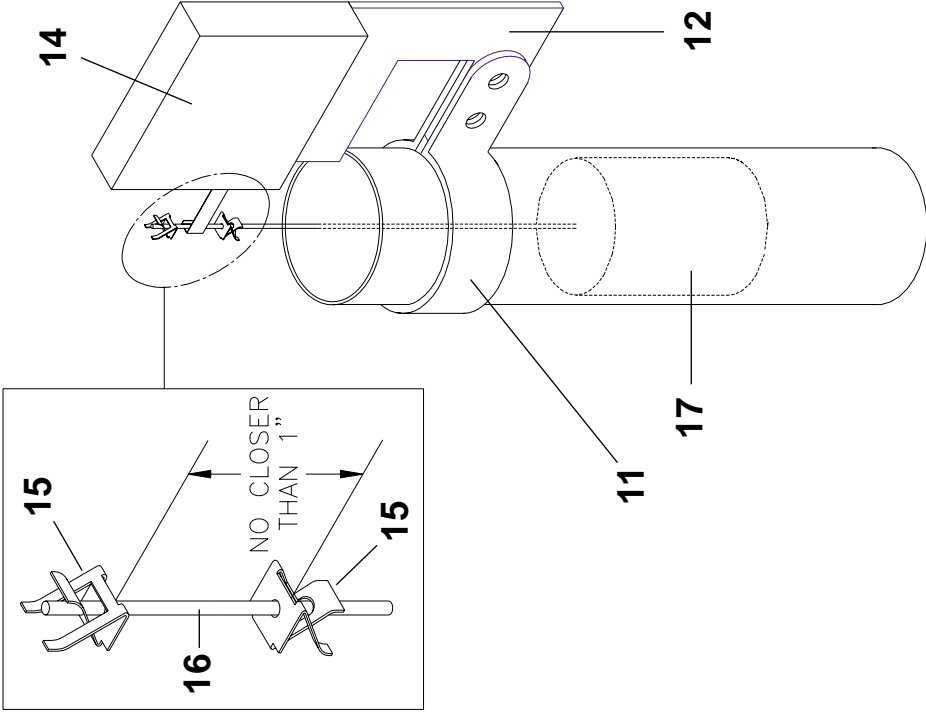
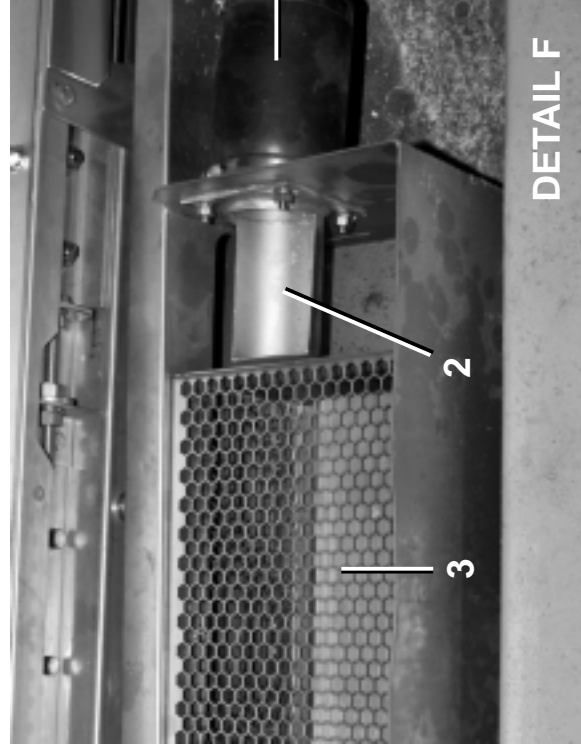
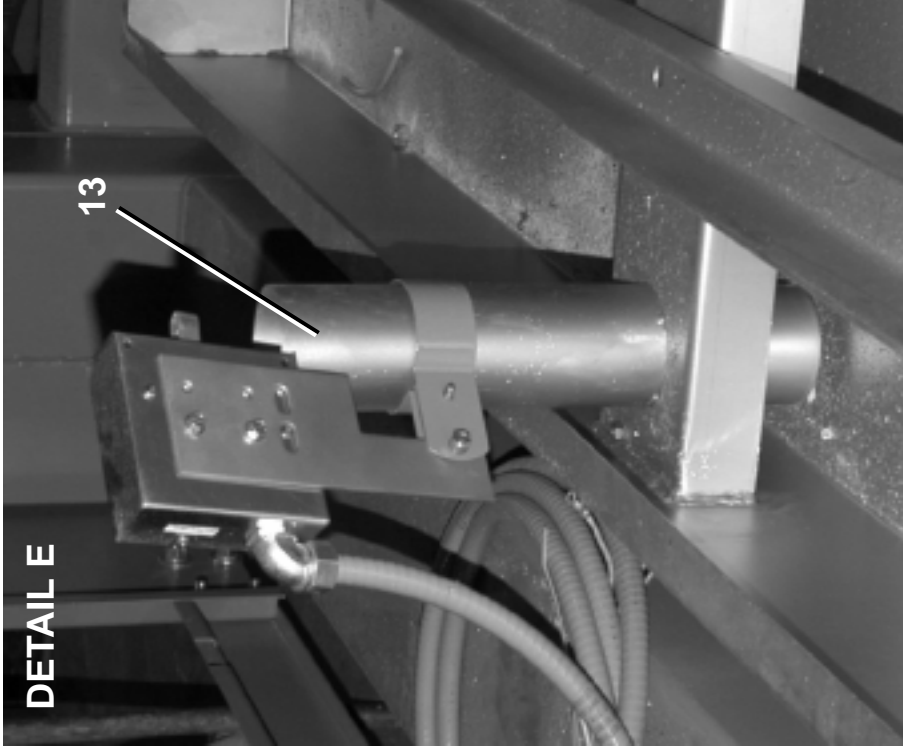
M7V4840C, M7V4836C



Pellerin Milnor Corporation
P. O. Box 400, Kenner, LA 70063-0400

BMP050046/2005105V
(Sheet 1 of 2)

Litho in U.S.A.



Speed Nut Adjustments (Item 15)

- 1) To adjust speed nut, pinch ends together and slide in desired direction.
- 2) Do not use tools to move speed nut.
- 3) To raise low level, move top speed nut down on rod.

Parts List—Reuse Tank & Level Switch

Find the correct assembly first, then find the needed components. The item letters (A, B, C, etc.) assigned to assemblies are referred to in the "Used In" column to identify which components belong to an assembly. The item numbers (1, 2, 3, etc.) assigned to components relate the parts list to the illustration.

Used In	Item	Part Number	Description	Comments
			ASSEMBLIES	
			COMPONENTS	
			none	
			REUSE TANK WLMT-4840M	
			OVERFLOW TUBE WLMT-SSPRESS	
			*WLMT=REUSE PERF GUARD	
			KINGREDNIP1.5IDX1.25MP#STC2015	
			HOSE1.5"WIREINSERT#7216-TRANS	
			HOSECLAMP1+5/16-2.25SSSC#HSS28	
			NPT PLUG 1/2 SQSOLID BRASS	
			DFW56-33PMSP RUBB CONN.	
			EXTCONV REAR STOP BRKT	
			SSPRESS LEVEL SWITCH ASSY	
			CLAMP=3"FLOAT CHAMBER DAS	
			BKT=LEVCONT 42DPS	
			*FLOAT ASSY L=25"-STD LEVEL	
			*WATER LEV SW ASSY: 1 UP+ 1LO	
			10-24 SPEDNUT #C10733-1024-373	
			LEVEL CONTROL FLOAT ROD=25"L	
			FLOAT=PLAST LVL CONT(SANDED)	
all	1	W4 21812		
all	2	W4 23026		
all	3	W3 16364		
all	4	51E098AS		
all	5	60E099		
all	6	27A060S		
all	7	5SP0KBESS		
all	8	60B075		
all	9	04 21843		
all	10	A72RF005		
all	11	02 15642S		
all	12	02 15097S		
all	13	SA 02 011		
all	14	ELL000MK2		
all	15	17N050		
all	16	02 02146		
all	17	X2 02239		

2

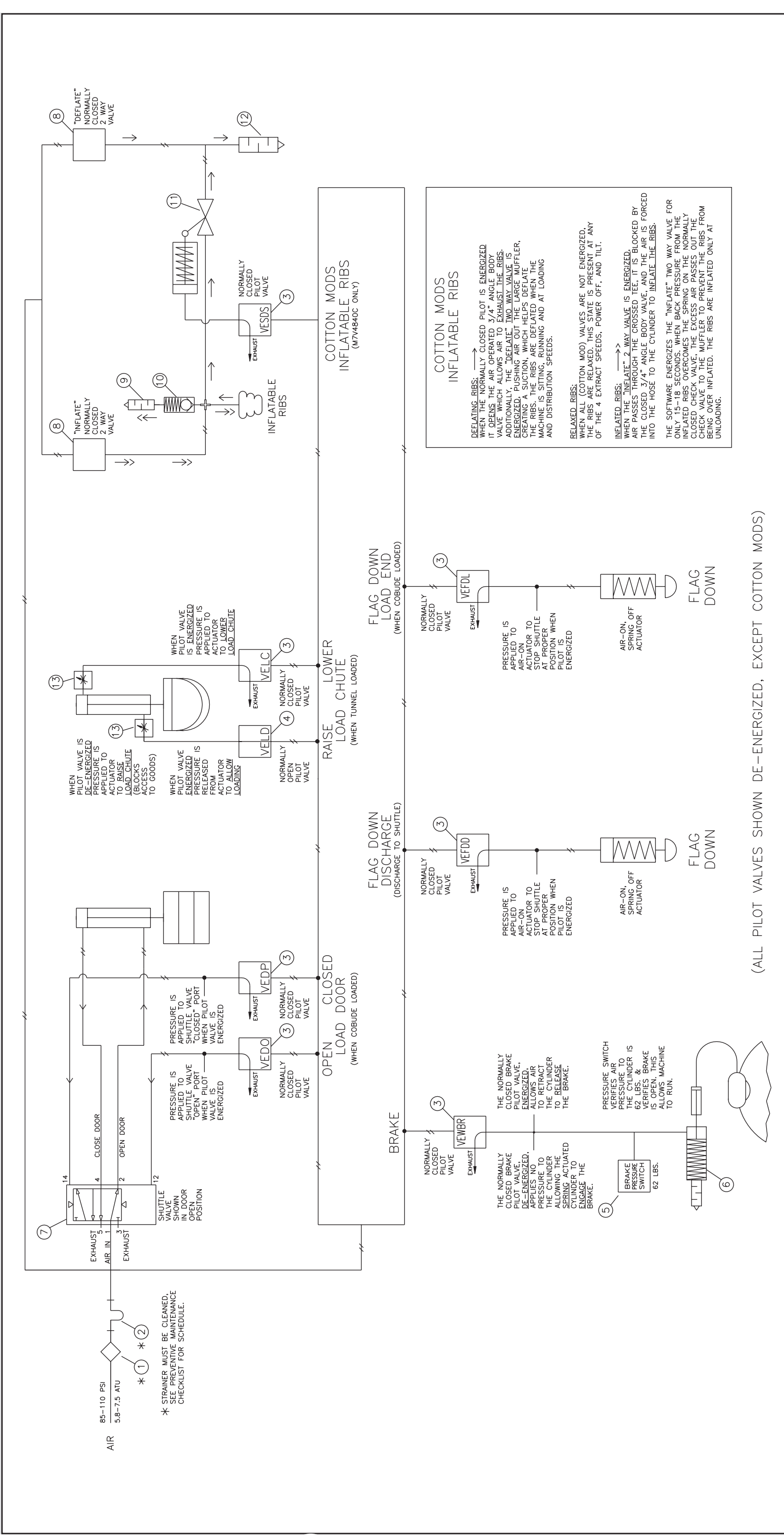
Pneumatic Piping and Assemblies

2.6



Pellerin Milnor Corporation
P. O. Box 400, Kenner, LA 70063-0400

Litho in U.S.A.



(ALL PILOT VALVES SHOWN DE-ENERGIZED, EXCEPT COTTON MODS)



Pellerin Milnor Corporation
P. O. Box 400, Kenner, LA 70063-0400

Litho in U.S.A.

Parts List—Pneumatic Schematic
Find the correct assembly first, then find the needed components. The item letters (A, B, C, etc.) assigned to assemblies are referred to in the "Used In" column to identify which components belong to an assembly. The item numbers (1, 2, 3, etc.) assigned to components relate the parts list to the illustration.

Used In	Item	Part Number	Description	Comments
			ASSEMBLIES-----	
			none	
			COMPONENTS-----	
			STRAINER 1/4 AND.BRASS#234S-L	
all	1	51T020		
all	2	30N601		
all	3	96R301B37		
all	4	96R302B37		
all	5	09N082A		
all	6	27A005A		
all	7	96N0010H		
all	8	96TBC2BA37		
all	9	27A005B		
all	10	96D046		
all	11	96D0009E		
all	12	27A005C		
all	13	96H018		
			CK VAL 3/4" #600-Z3 W/S/S DISH	
			3/4"NPTBRZ N/C STEAMVAL ANGBOD	
			MUFFLER 2" BANTAM B168	
			MUFFLER 1/2" BANTAM B48	
			1/4" N/C 2WAY 120V50/60C VALVE	
			SHUTLVLV 1/4" 4WAY AIOPERATED	
			MUFF 1/4" ALLIED B-28 BANTAM	
			PRESSW NASON CLOSE @ 62 LB.	
			1/8"AIPILOT 3W NO 120V50/60	
			1/8"AIPILOT 3W NC 120V50/60	
			1/2"AIRLINE FILTER PH#07F35AC	
			ANGLE NEEDLE VLV 1/4" T X 1/8MP	

Air Cylinder Brake Assembly

48040F7J,F7B,F7N,F7W

BMP020038/2002226V
(Sheet 1 of 2)



Pellerin Milnor Corporation
P. O. Box 400, Kenner, LA 70063-0400

Litho in U.S.A.

NOTES:
TIGHTEN LOCKNUT UNTIL IT IS JUST BARELY POSSIBLE TO TURN THE PISTON CUP AND WASHER ASSEMBLY ON THE STEM. CORRECT PISTON CUP SHAPE IS SHOWN IN FIGURE 1.

DO NOT OVER TIGHTEN, AS THIS CAUSES THE PISTON CUP TO DEFORM TO THE SHAPE SHOWN IN FIGURE 2 AND MAY CAUSE PISTON TO BIND IN CYLINDER.

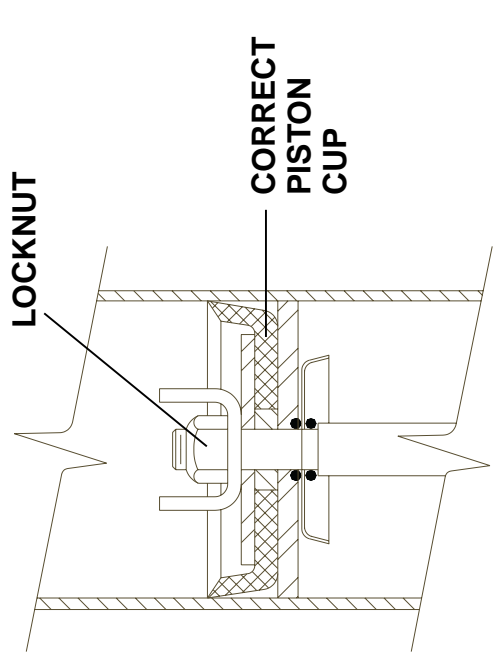
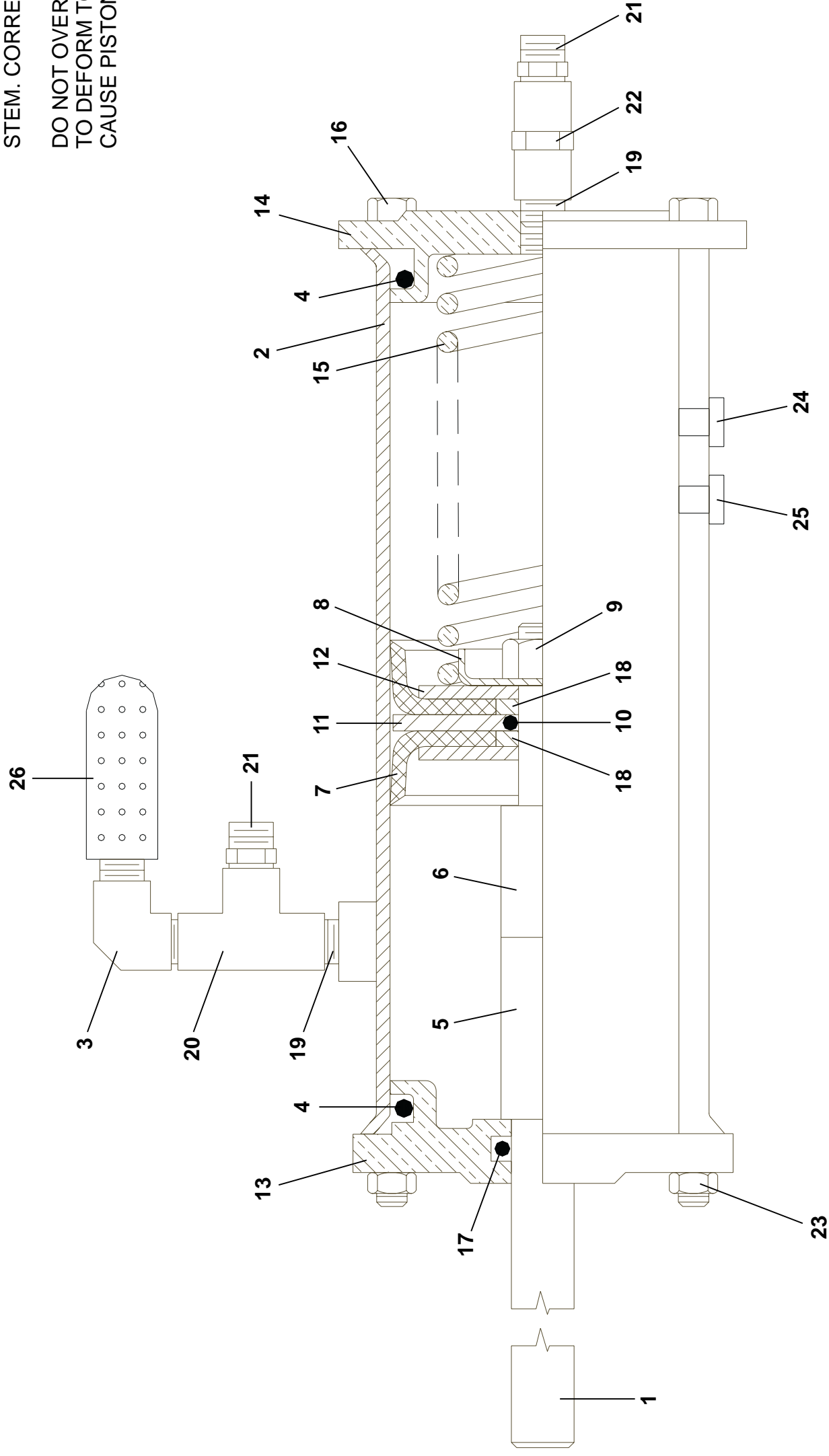


FIGURE 1

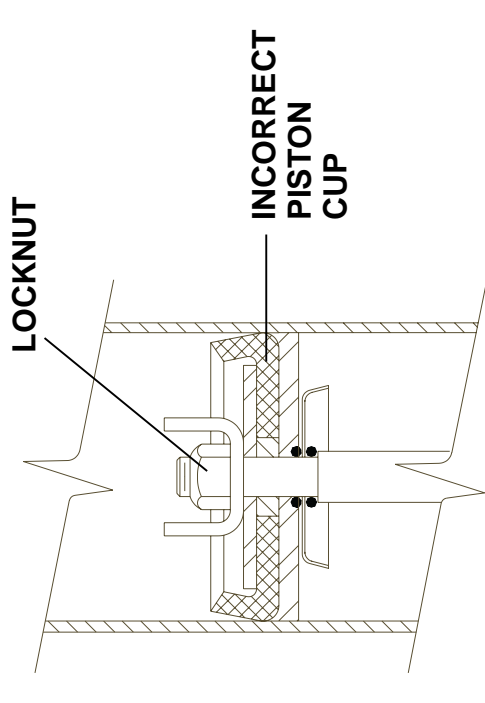


FIGURE 2



Pellerin Milnor Corporation
P. O. Box 400, Kenner, LA 70063-0400

Litho in U.S.A.

Parts List—Air Cylinder Brake Assembly

Find the correct assembly first, then find the needed components. The item letters (A, B, C, etc.) assigned to assemblies are referred to in the "Used In" column to identify which components belong to an assembly. The item numbers (1, 2, 3, etc.) assigned to components relate the parts list to the illustration.

Used In	Item	Part Number	Description	Comments
			-----ASSEMBLIES-----	
	A	AAC4840F	AIRCYL=BRAKE ASSY, 4840F7	
			-----COMPONENTS-----	
all	1	02 18650B	STEM=2WAY AIRCYL BRAKE 7.88L	
all	2	W2 18646	*CYLINDER-AIR=DOUBLEACT BRAKE	
all	3	53A031XB	BODY-EL90MALE.25X25 #269C-4-4B	
all	4	60C132	ORING 2"IDX3/16CS BUNA70 #329	
all	5	27B250	SPCRROLL.5ID1.5L.062T STLZNC	
all	6	27B34010SS	SPACERROLL .51ID.625L.062T SS	
all	7	02 02194	PISTONCUP=DUMPVALVE 2+3/8"	
all	8	02 18651	WASHER=2 WAY BRAKE CYL	
all	9	15G220	NUTLOK THINHX 3/8-24 SS/NYL	
all	10	60C106	ORING 5/16ID 1/16CS BUNA70#011	
all	11	02 02105B	2.38"ACYL BRASS PISCUP WASHR	
all	12	02 02085	UP WASHER=2"OD=PISTON CUP	
all	13	06 20702E	FLOW NOT ACTUATOR CYL HEAD	
all	14	02 02101	CYLHEAD W/TAPPED HOLE	
all	15	02 21865	SPRING=BRAKE ACT, 4840F	
all	16	W6 20702F	*FLOW NOT VLV=AIR-CYL ROD WLD	
all	17	60C110	ORING 1/2IDX3/32CS BUNA70 #112	
all	18	02 02185	WASHER=PISTON CUP COMP LIMIT	
all	19	5N0ECLSBE2	NPT NIP 1/4XCLS TBE BRASS 125#	
all	20	51V015	TEE 1/4 FGDBRASS 101T7-444	
all	21	53A008B	BODYMALECON.25X.25COMP#B68A-4B	
all	22	5SCC0EBE	NPT COUP 1/4 BRASS 125# W/HEX	
all	23	15G185	HXNUT 5/16-18UNC2B SAE ZINC GR	
all	24	20L601F	ID TAG NAT'L #1614 ALUM EMB LE	
all	25	20L601X	ID TAG NAT'L #1614 ALUM EMB LE	
all	26	27A005A	MUFF 1/4" ALLIED B-28 BANTAM	

2

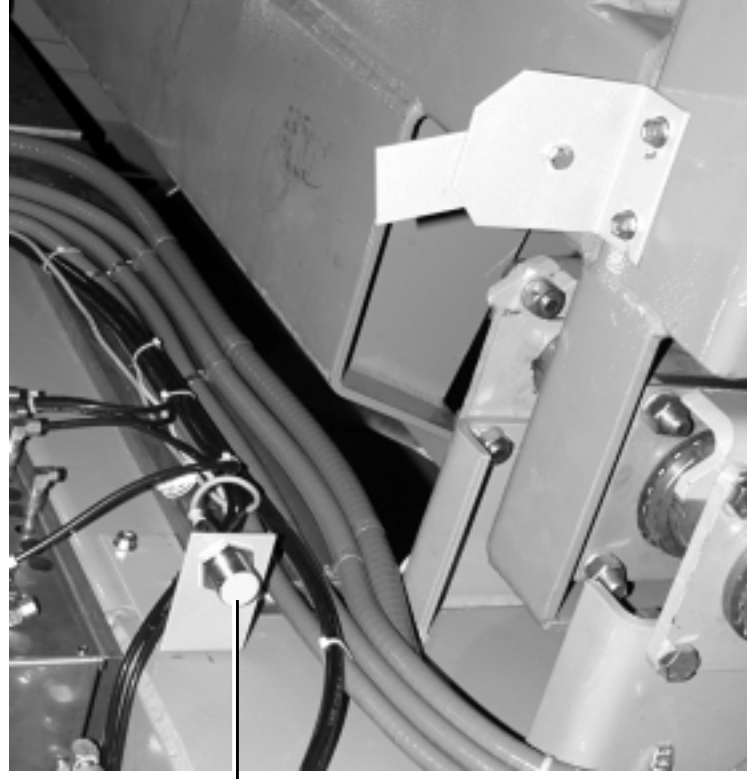
Control and Sensing Assemblies

2.7

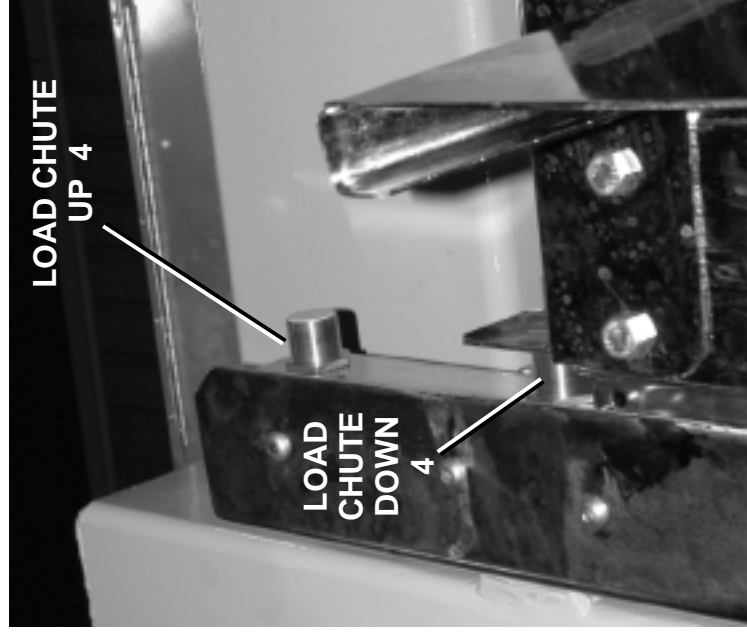


Pellerin Milnor Corporation
P. O. Box 400, Kenner, LA 70063-0400

Litho in U.S.A.

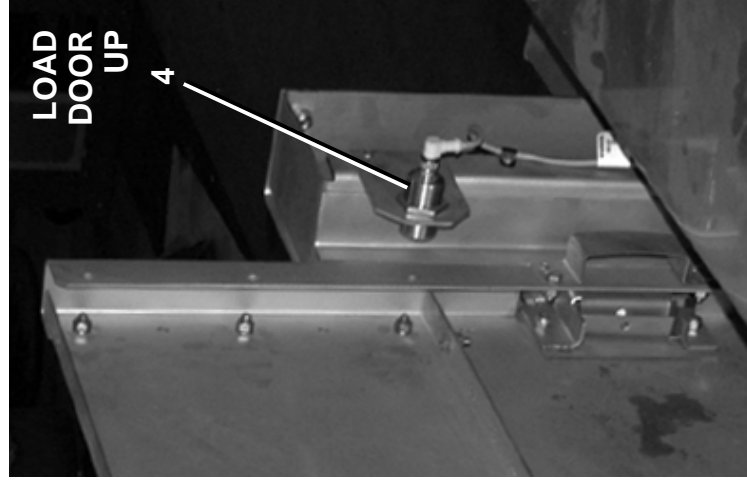


2
FULL UP
SWITCH

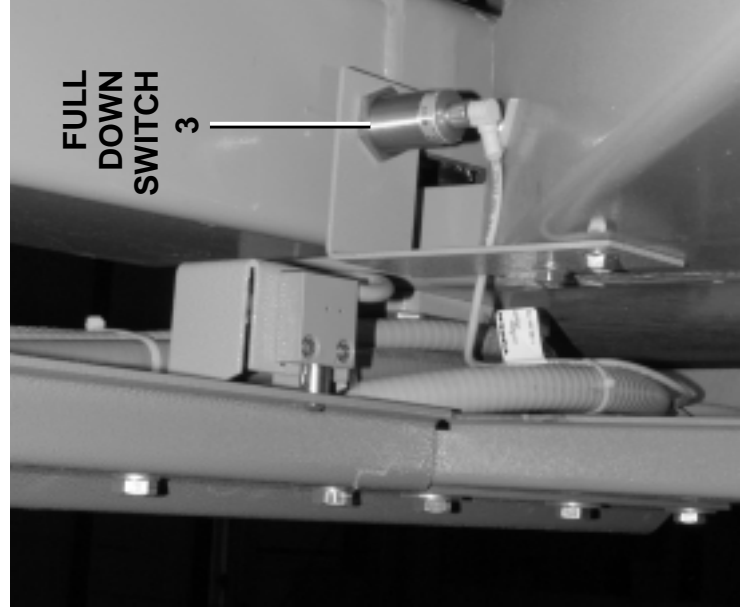


LOAD CHUTE
UP 4

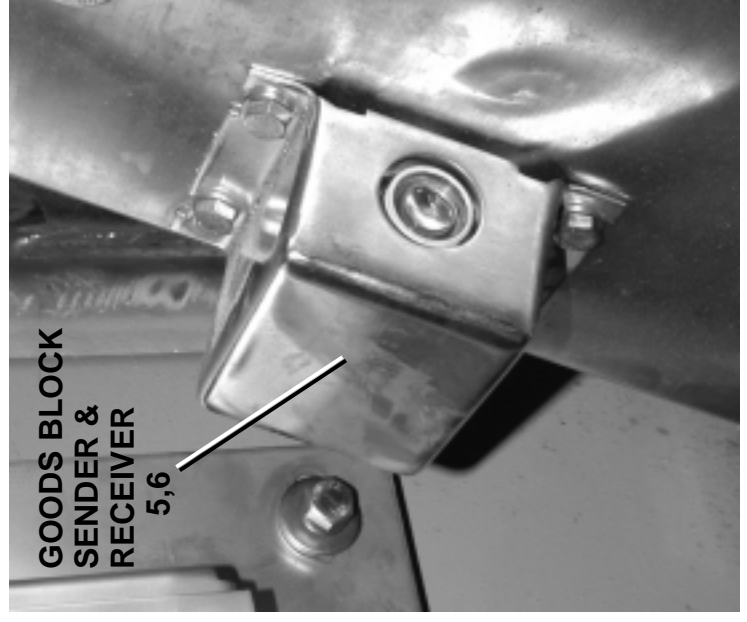
LOAD CHUTE
DOWN 4



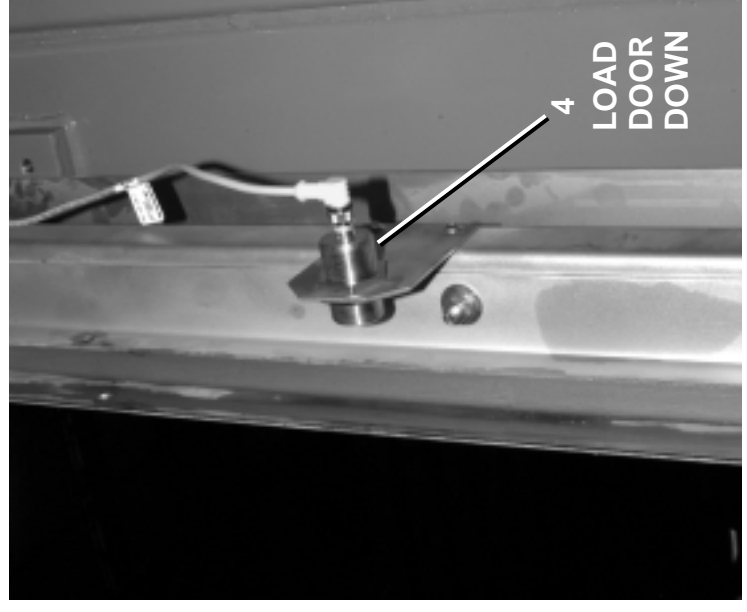
LOAD DOOR
UP 4



FULL
DOWN
SWITCH 3



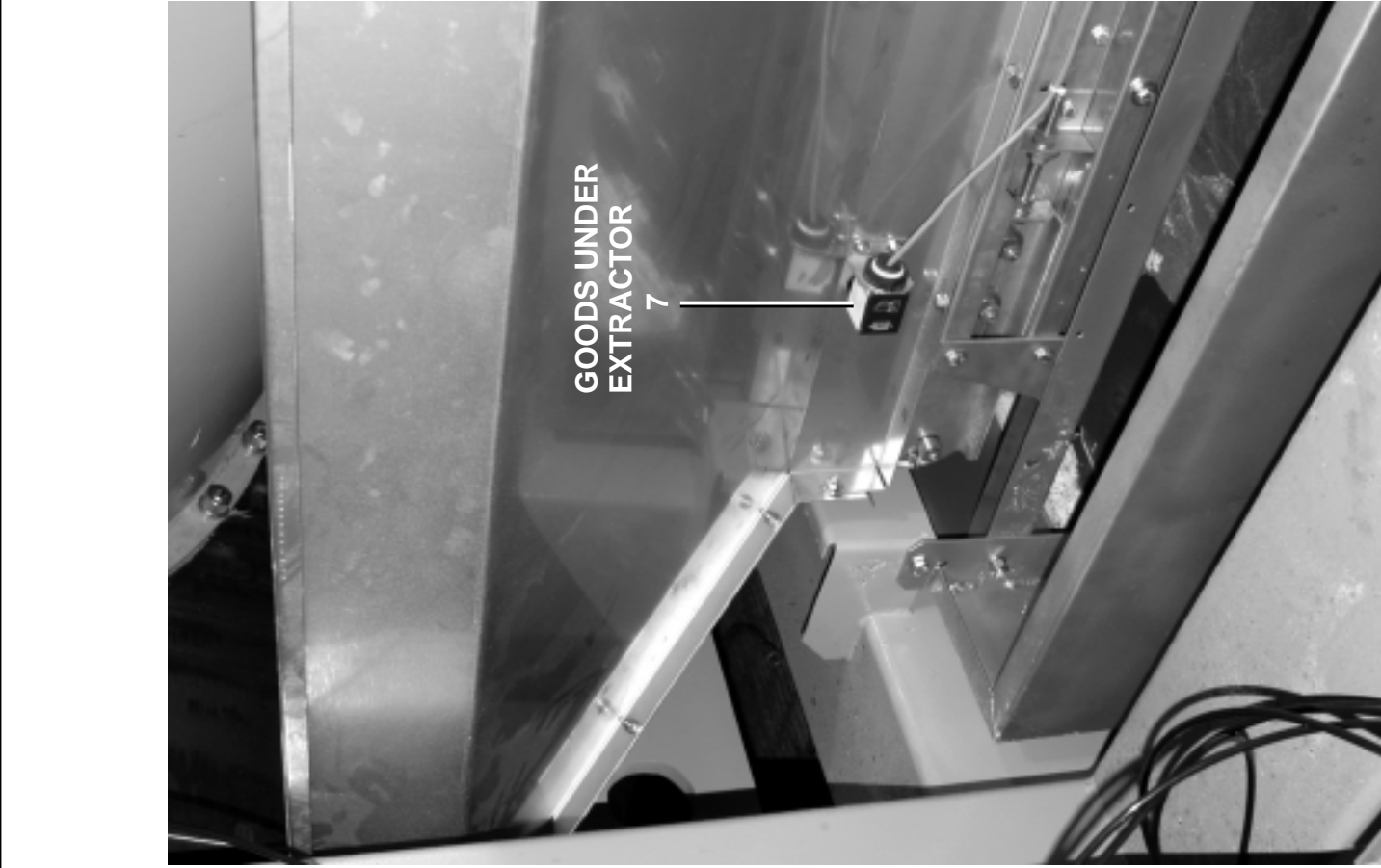
GOODS BLOCK
SENDER &
RECEIVER
5,6



LOAD DOOR
DOWN 4



SPEED SENSOR
1,1A,1B



Parts List—Sensors
 Find the correct assembly first, then find the needed components. The item letters (A, B, C, etc.) assigned to assemblies are referred to in the "Used In" column to identify which components belong to an assembly. The item numbers (1, 2, 3, etc.) assigned to components relate the parts list to the illustration.

Used In	Item	Part Number	Description	Comments
			-----ASSEMBLIES-----	
			none	
			-----COMPONENTS-----	
all	1	09RPE013Q	SENSOR E-Z BEAM QUICK CONN DC	
all	1	09RPE013CS	SENSOR QC CABLE STR. 15'	
all	1	09RPS12AAS	PROXSW QD CONN 12M NO-AC SHLD	
all	2	09RPS30ADS	PROX SW QK CONN 30M NO-DC SHLD	
all	3	09RPS30CAS	PROXSW QK CONN 30M NO-AC SHLD	
all	4	09RPS30ADS	PROX SW QK CONN 30M NO-DC SHLD	
all	5	09RPE010R	PHOTOEYE RECEIVER AC	
all	6	09RPE010E	P.E. EMITTER AC #SM303E W/30'	
all	7	09RPE004	PE DARK OP AC N/O-OUT 24-240V	

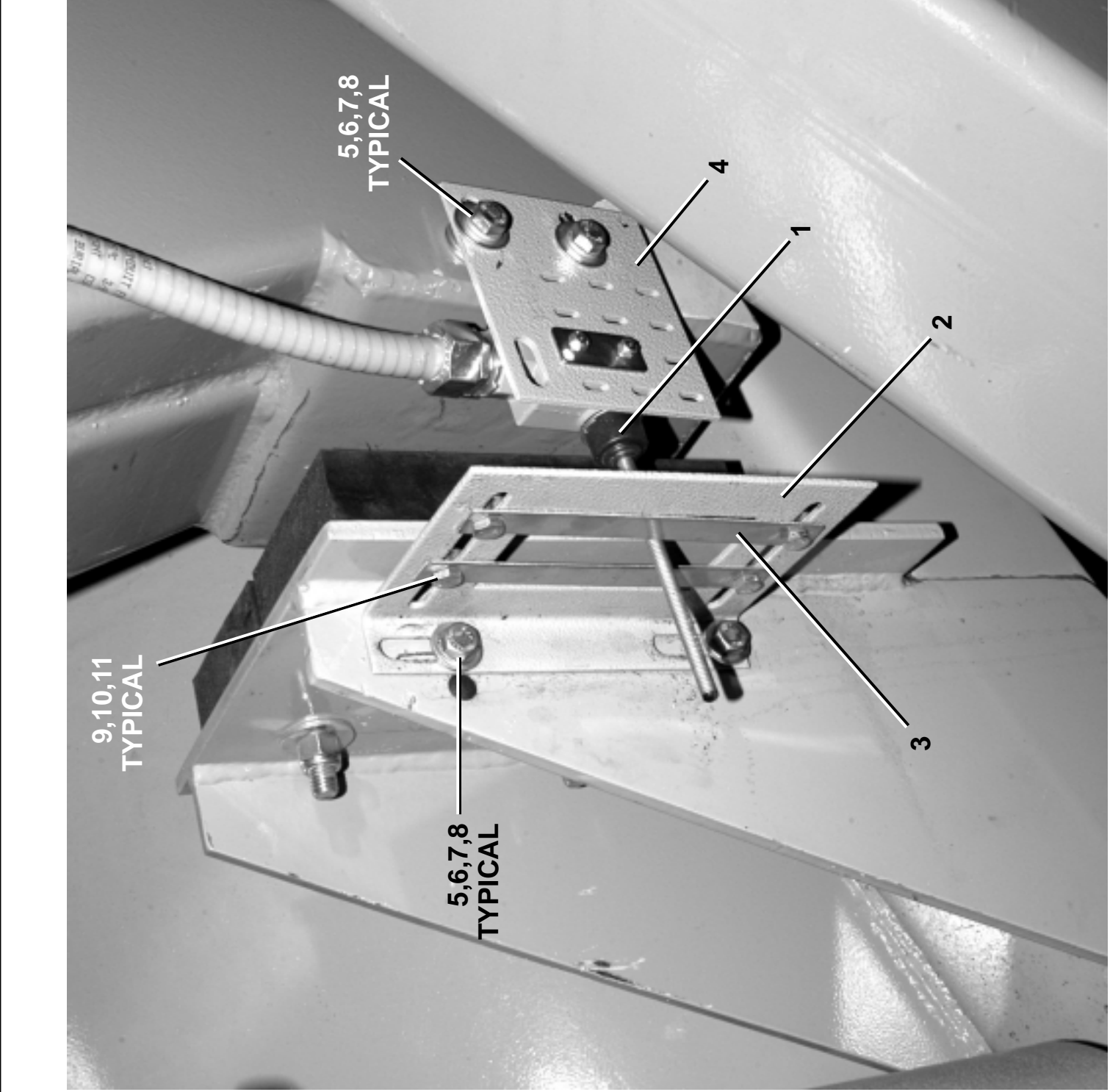
Excursion Switch
M7V4840C, M7V4836C



Pellerin Milnor Corporation
 P. O. Box 400, Kenner, LA 70063-0400

Litho in U.S.A.

BMP050044/2005105V
 (Sheet 1 of 1)



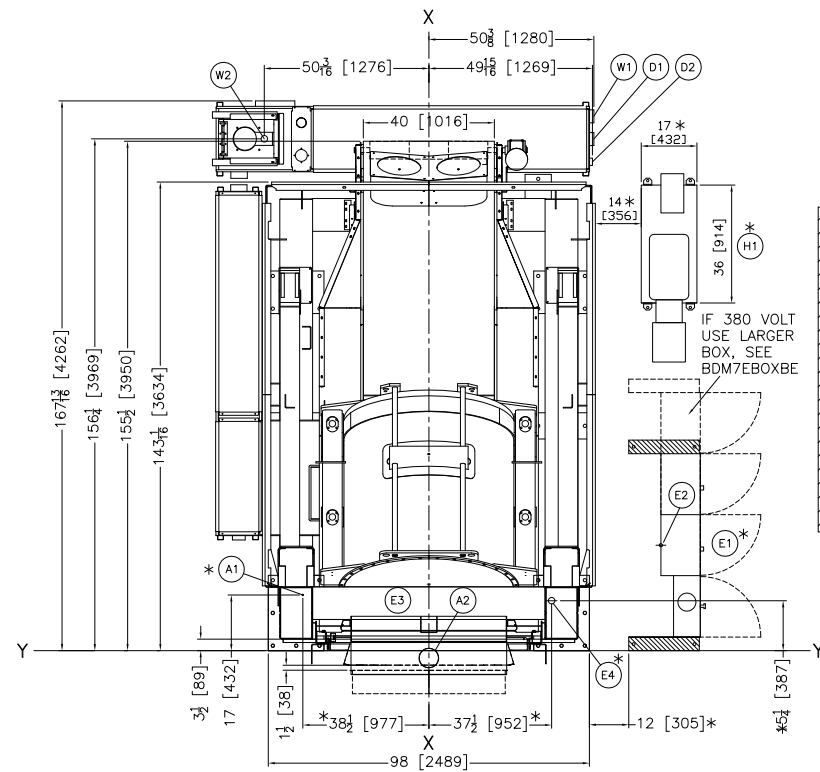
Parts List—Excursion Switch
 Find the correct assembly first, then find the needed components. The item letters (A, B, C, etc.) assigned to assemblies are referred to in the "Used In" column to identify which components belong to an assembly. The item numbers (1, 2, 3, etc.) assigned to components relate the parts list to the illustration.

Used In	Item	Part Number	Description	Comments
	A	ASE17001	SHELL ASSY 4840M	
			-----ASSEMBLIES-----	
			-----COMPONENTS-----	
all	1	09R008ASTD	* 09R008A+MOUNTING HDWRE+INST	
all	2	03 65234	E-SWITCH WINDOW ANGL T.F.	
all	3	03 65234B	EXCURSION WINDOW PLATES	
all	4	02 15783A	*PLATE=EXCURSION SW MTG	
all	5	15K084	TRUSS HXSOK 3/8-16 X 23/32SS	
all	6	15U240	FLATWASHER(USS STD) 3/8" ZNC P	
all	7	15U255	LOCKWASHER MEDIUM 3/8 ZINCPL	
all	8	15G205	HXNUT 3/8-16UNC2B ZINC GR2	
all	9	15K038B	1/4-20X 1/2 HEXFLANGE SCREW	
all	10	15U180	LOCKWASHER MEDIUM 1/4 ZINCPL	
all	11	15G165	HXNUT 1/4-20UNC2BSAE ZC GR2	

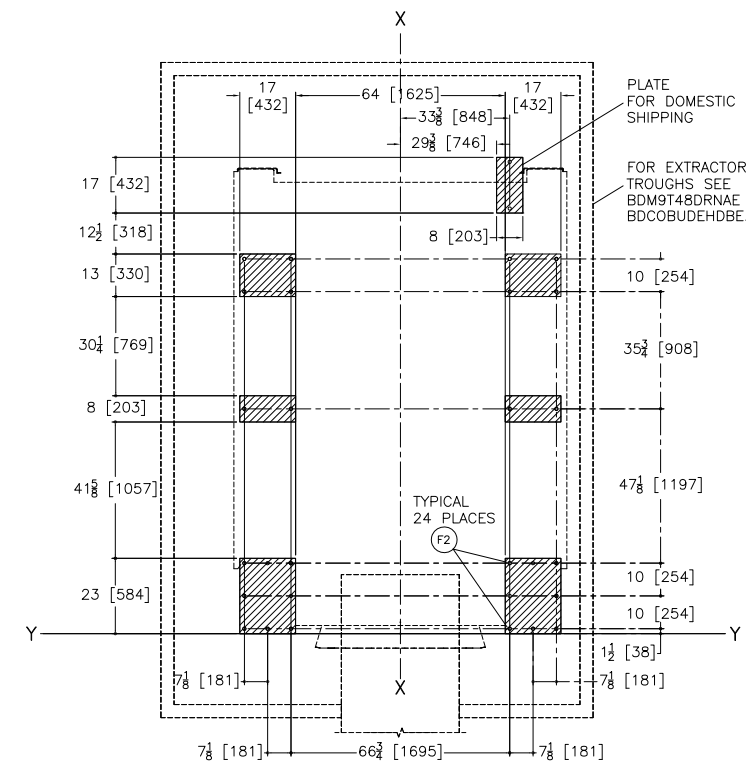
2

Dimensional Drawings

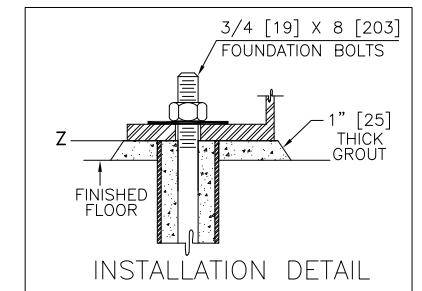
2.8



PLAN VIEW

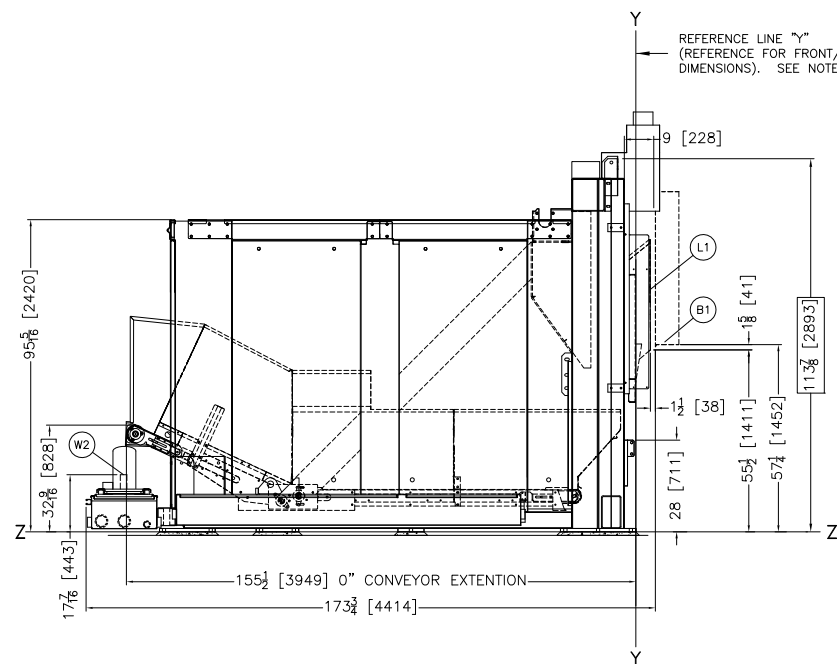


FOUNDATION PLAN VIEW

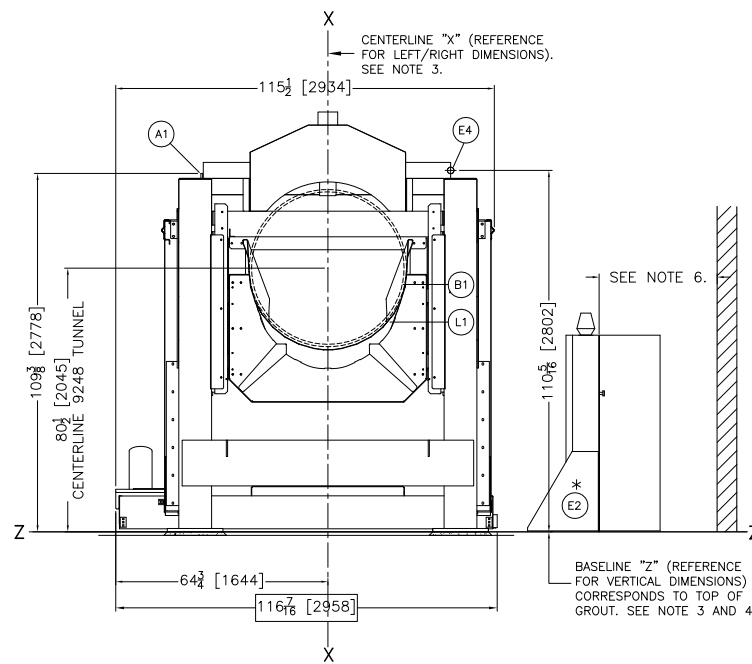


INSTALLATION DETAIL

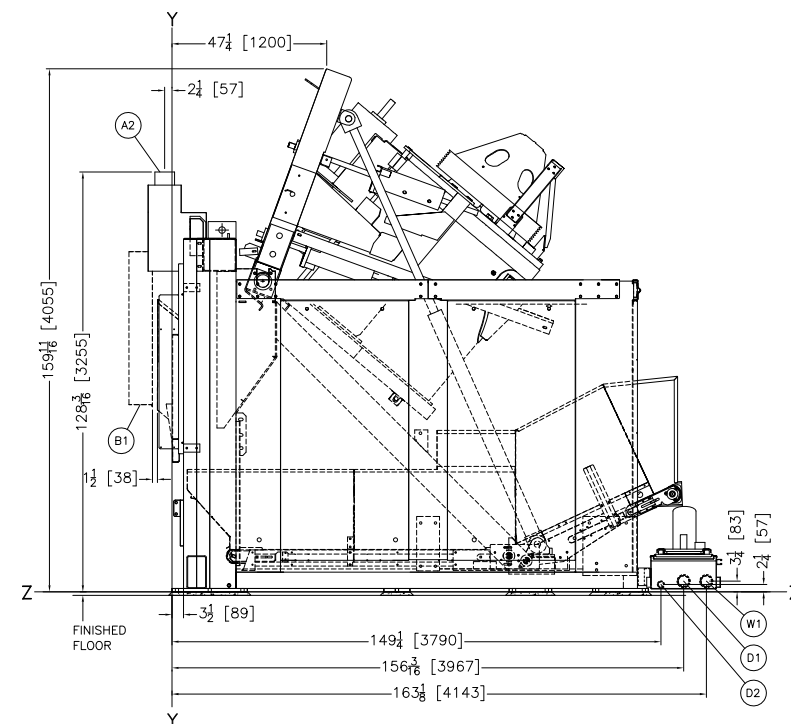
W2	REUSE PUMP, WATER TO TUNNEL, 2" HOSE CONNECTION
W1	REUSE WATER FROM LAST MODULE OF TUNNEL, 3" NPT, PIPING SUPPLIED BY PMC.
T2	REUSE PUMP TANK
T1	SIDE TANK
L1	LOAD CHUTE
H1	HYDRAULIC TANK
F2	ANCHOR BOLT HOLES. 1" [25] DIAMETER, 24 PLACES
F1	BASE PADS
E4	POWER AND CONTROL CONNECTIONS INTO JUNCTION BOX
E3	JUNCTION AND AIR VALVE BOX
E2	ELECTRICAL CONNECTION FROM CONTROL BOX
E1	CONTROL BOX, SEE BDM7EBOXAE.
D2	TANK MANUAL DRAIN 1-1/2" PVC TO SEWER
D1	OVER FLOW TO SEWER, 3" PIPE SOCKET JOINT CONNECTION
C1	DISCHARGE CONVEYOR
B1	TUNNEL DISCHARGE RING
A2	HOOD VENT, 6" [152] DIAMETER, SEE NOTE 8.
A1	MAIN AIR CONNECTION, 1/4" NPT
ITEM	LEGEND



LEFT VIEW



FRONT VIEW



RIGHT VIEW

NOTES

8 THE BEST PRACTICE IS TO PROVIDE TWO SEPARATE, POWERED VENTILATION UNITS THAT MEET THE FOLLOWING CONDITIONS:
 A) THE TWO UNITS ARE ISOLATED FROM EACH OTHER TO AVOID HARMFUL CHEMICAL REACTIONS.
 B) VENTILATION FANS HAVE SUFFICIENT POWER TO DRAW VAPORS AWAY FROM THE EQUIPMENT. MINOR RECOMMENDATIONS:
 *500 SCFM PER CONNECTION POINT FOR THE OXIDATION ZONE
 *750 SCFM PER CONNECTION POINT FOR THE FINISH ZONE AND PRESS ENCLOSURE.
 C) FAN MOTORS SHOULD BE EQUIPPED WITH AN ALARM (EXAMPLE: INDICATOR LIGHT) TO ALERT PERSONNEL IF A MOTOR FAILS.

7 TANKS ARE REMOVED FOR SHIPPING. LOCATE AS SHOWN AT INSTALLATION.

6 AS OF THIS WRITING, THE MINIMUM CLEARANCE REQUIRED BY U.S. NATIONAL ELECTRIC CODES, FROM ELECTRIC BOX TO ANY OBJECT IS:
 36 [914] IF OBJECT IS AN UNGROUNDED (INSULATED) WALL
 42 [1067] IF OBJECT IS A GROUNDED WALL (ie. BARE CONCRETE, BRICK, ETC.)
 48 [1219] IF OBJECT IS ANY LIVE PART.
 CHECK LOCAL ELECTRIC CODES FOR FURTHER RESTRICTIONS.

5 CUSTOMER TO SUPPLY CIRCUIT BREAKER OR FUSED BRANCH CIRCUIT DISCONNECT (SAFETY) SWITCHES WITH LAG TYPE FUSES FROM POWER SOURCE TO MACHINE. A SEPARATE GROUND WIRE MUST BE CONNECTED FROM DISCONNECT TO EQUIPMENT.

4 BASELINE "Z" IS THE SAME FOR ALL MILNOR MACHINES AND IS SHOWN ON ALL DIMENSIONAL DRAWINGS. THE DISTANCE BETWEEN BASELINE "Z" AND THE FINISHED FLOOR MAY VARY (WITH CHANGES IN FLOOR HEIGHT) AS REQUIRED TO INSURE THAT BASELINE "Z" IS HORIZONTAL AND ALL COMPONENTS REQUIRING GROUT ARE SET ON A MINIMUM 1" [25] THICK GROUT BED.

3 USE REFERENCE LINES "X", "Y", AND "Z" TO LOCATE ALL SERVICE CONNECTIONS.

2 NUMBERS IN BRACKETS [] DENOTE DIMENSIONS IN MILLIMETERS.

1 ALL DIMENSIONS SHOWN ARE APPROXIMATE, SUBJECT TO NORMAL MANUFACTURING TOLERANCES, AND TO OCCASIONAL CHANGES WITHOUT NOTICE THROUGH REDESIGN AND/OR RELOCATION OF COMPONENTS, ETC. DO NOT USE FOR CONSTRUCTION UNLESS CERTIFIED, AND IN NO EVENT PRE-PIPE CLOSER THAN FIVE FEET FROM MACHINE. FACTORY MUST BE CONSULTED FOR DIMENSIONS IF MACHINE IS TO BE MOVED THROUGH NARROW OR LOW CORRIDORS OR OPENINGS.

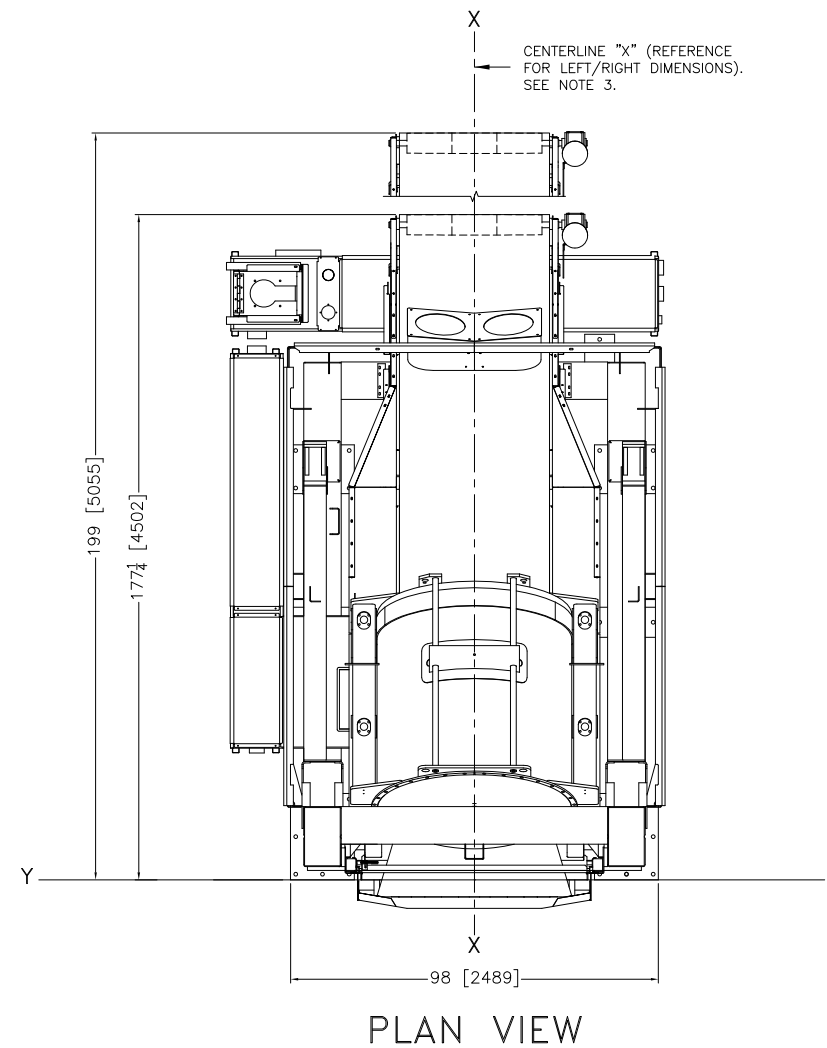
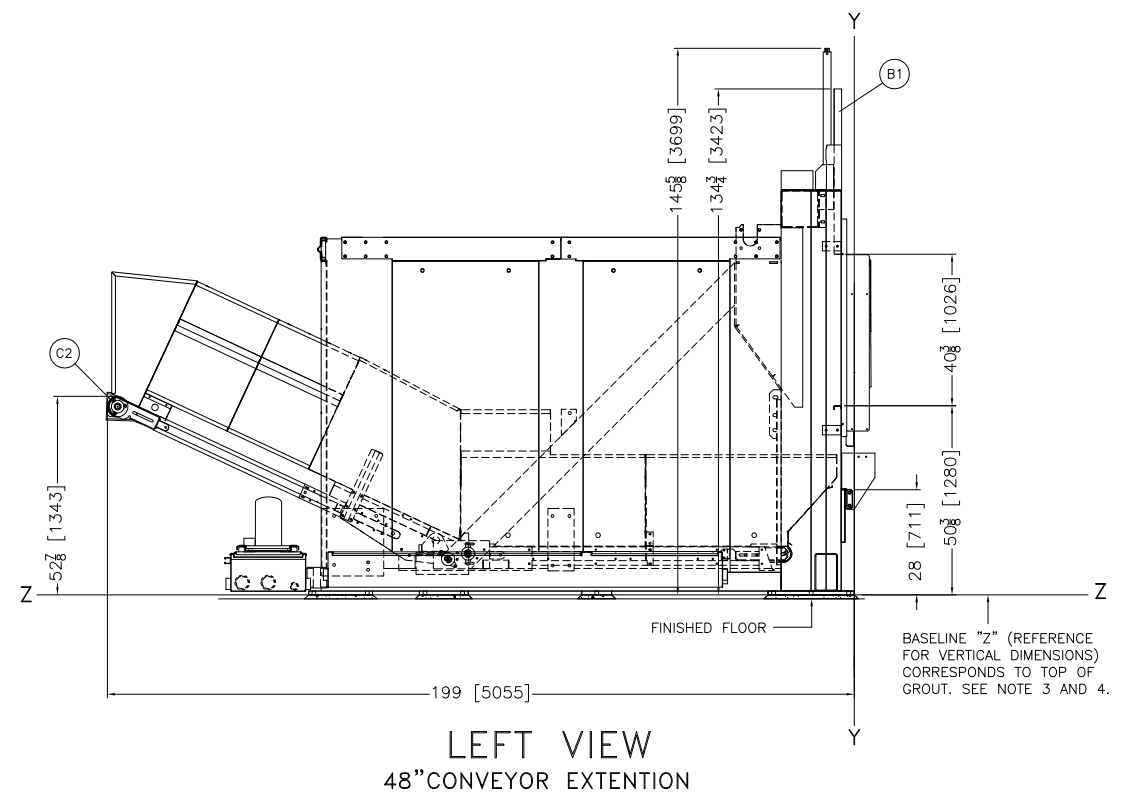
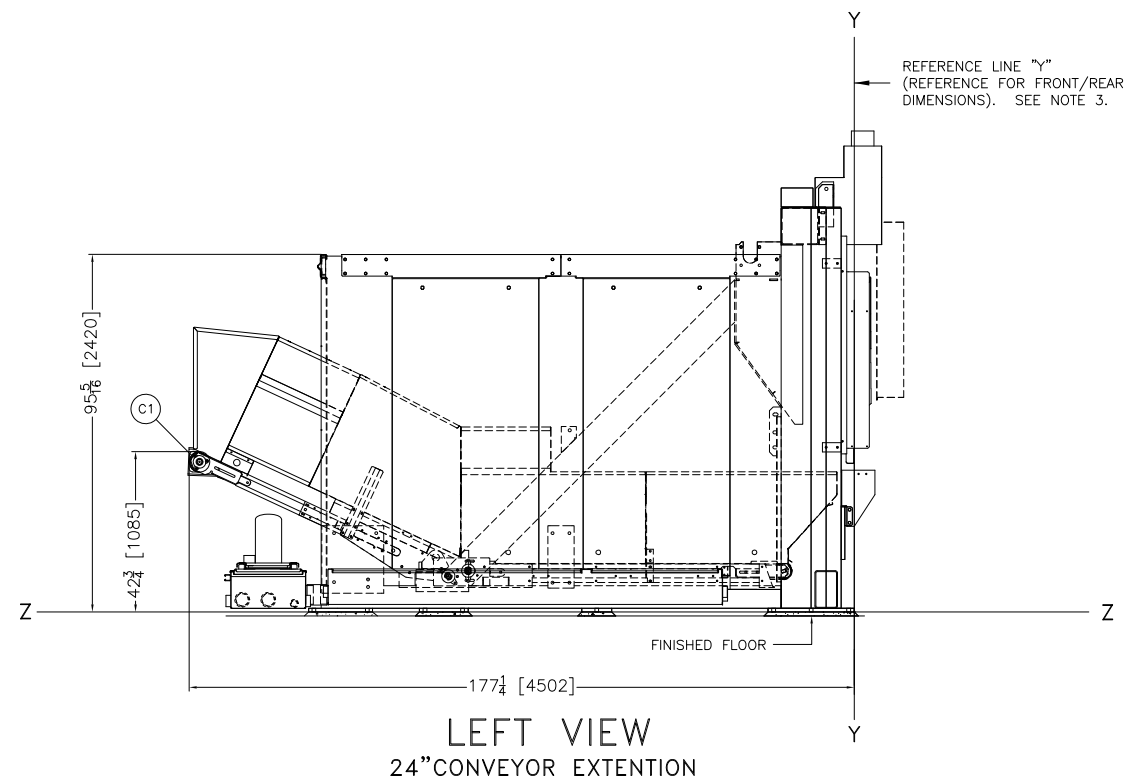
ATTENTION
 MOST REGULATORY AUTHORITIES (INCLUDING OSHA IN THE USA) HOLD THE OWNER/USER ULTIMATELY RESPONSIBLE TO MAINTAIN A SAFE WORKING ENVIRONMENT. ACCORDINGLY, THE OWNER/USER MUST RECOGNIZE ALL FORESEEABLE SAFETY HAZARDS, FURNISH SAFETY INSTRUCTIONS AND GUIDANCE TO ALL PERSONNEL WHO MAY COME IN CONTACT WITH THE INSTALLATION, AND PROVIDE ALL NECESSARY ADDITIONAL SAFETY GUARDS, FENCES, RESTRAINTS, DEVICES, ETC., NOT FURNISHED BY THE EQUIPMENT MANUFACTURER OR VENDOR.

ATTENTION
 THE FLOOR AND/OR OTHER SUPPORT COMPONENTS MUST HAVE SUFFICIENT STRENGTH (AND RIGIDITY WITH DUE CONSIDERATION FOR NATURAL OR RESONANT FREQUENCY THEREOF) TO WITHSTAND THE FULLY LOADED WEIGHT OF THE MACHINE INCLUDING THE GOODS, THE WATER, AND ANY REPEATED SINUSOIDAL (ROTATING) FORCES GENERATED DURING ITS OPERATION. WRITE THE FACTORY FOR ADDITIONAL MACHINE DATA FOR USE BY A COMPETENT SOIL AND/OR STRUCTURAL ENGINEER.

M7T/M9T4840C/36C

DWG# BDM9T4840CAE 2017044D

MILNOR PELLERIN MILNOR CORPORATION
 P.O. Box 400 Kenner, LA 70063, USA, Phone 504/467-9591,
 FAX 504/468-3094, Email: milnorinfo@milnor.com



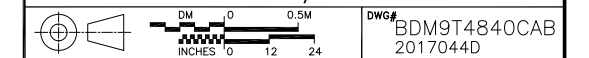
C2	CONVEYOR, OPTIONAL 48" EXTENTION
C1	CONVEYOR, OPTIONAL 24" EXTENTION
B1	OPTIONAL COBUDE LOADING DOOR
ITEM	LEGEND

- NOTES**
- AS OF THIS WRITING, THE MINIMUM CLEARANCE REQUIRED BY U.S. NATIONAL ELECTRIC CODES, FROM ELECTRIC BOX TO ANY OBJECT IS:
36 [914] IF OBJECT IS AN UNGROUNDED (INSULATED) WALL.
42 [1067] IF OBJECT IS A GROUNDED WALL (ie. BARE CONCRETE, BRICK, ETC.)
48 [1219] IF OBJECT IS ANY LIVE PART.
CHECK LOCAL ELECTRIC CODES FOR FURTHER RESTRICTIONS.
 - CUSTOMER TO SUPPLY CIRCUIT BREAKER OR FUSED BRANCH CIRCUIT DISCONNECT (SAFETY) SWITCHES WITH LAG TYPE FUSES FROM POWER SOURCE TO MACHINE. A SEPARATE GROUND WIRE MUST BE CONNECTED FROM DISCONNECT TO EQUIPMENT.
 - BASELINE "Z" IS THE SAME FOR ALL MILNOR MACHINES AND IS SHOWN ON ALL DIMENSIONAL DRAWINGS. THE DISTANCE BETWEEN BASELINE "Z" AND THE FINISHED FLOOR MAY VARY (WITH CHANGES IN FLOOR HEIGHT) AS REQUIRED TO INSURE THAT BASELINE "Z" IS HORIZONTAL AND ALL COMPONENTS REQUIRING GROUT ARE SET ON A MINIMUM 1" [25] THICK GROUT BED.
 - USE REFERENCE LINES "X", "Y", AND "Z" TO LOCATE ALL SERVICE CONNECTIONS.
 - NUMBERS IN BRACKETS [] DENOTE DIMENSIONS IN MILLIMETERS.
 - ALL DIMENSIONS SHOWN ARE APPROXIMATE, SUBJECT TO NORMAL MANUFACTURING TOLERANCES, AND TO OCCASIONAL CHANGES WITHOUT NOTICE THROUGH REDESIGN AND/OR RELOCATION OF COMPONENTS, ETC. DO NOT USE FOR CONSTRUCTION UNLESS CERTIFIED, AND IN NO EVENT PRE-PIPE CLOSER THAN FIVE FEET FROM MACHINE. FACTORY MUST BE CONSULTED FOR DIMENSIONS IF MACHINE IS TO BE MOVED THROUGH NARROW OR LOW CORRIDORS OR OPENINGS.

ATTENTION
MOST REGULATORY AUTHORITIES (INCLUDING OSHA IN THE USA) HOLD THE OWNER/USER ULTIMATELY RESPONSIBLE TO MAINTAIN A SAFE WORKING ENVIRONMENT. ACCORDINGLY, THE OWNER/USER MUST RECOGNIZE ALL FORESEEABLE SAFETY HAZARDS, FURNISH SAFETY INSTRUCTIONS AND GUIDANCE TO ALL PERSONNEL WHO MAY COME IN CONTACT WITH THE INSTALLATION, AND PROVIDE ALL NECESSARY ADDITIONAL SAFETY GUARDS, FENCES, RESTRAINTS, DEVICES, ETC., NOT FURNISHED BY THE EQUIPMENT MANUFACTURER OR VENDOR.

ATTENTION
THE FLOOR AND/OR OTHER SUPPORT COMPONENTS MUST HAVE SUFFICIENT STRENGTH (AND RIGIDITY WITH DUE CONSIDERATION FOR NATURAL OR RESONANT FREQUENCY THEREOF) TO WITHSTAND THE FULLY LOADED WEIGHT OF THE MACHINE INCLUDING THE GOODS, THE WATER, AND ANY REPEATED SINUSOIDAL (ROTATING) FORCES GENERATED DURING ITS OPERATION. WRITE THE FACTORY FOR ADDITIONAL MACHINE DATA FOR USE BY A COMPETENT SOIL AND/OR STRUCTURAL ENGINEER.

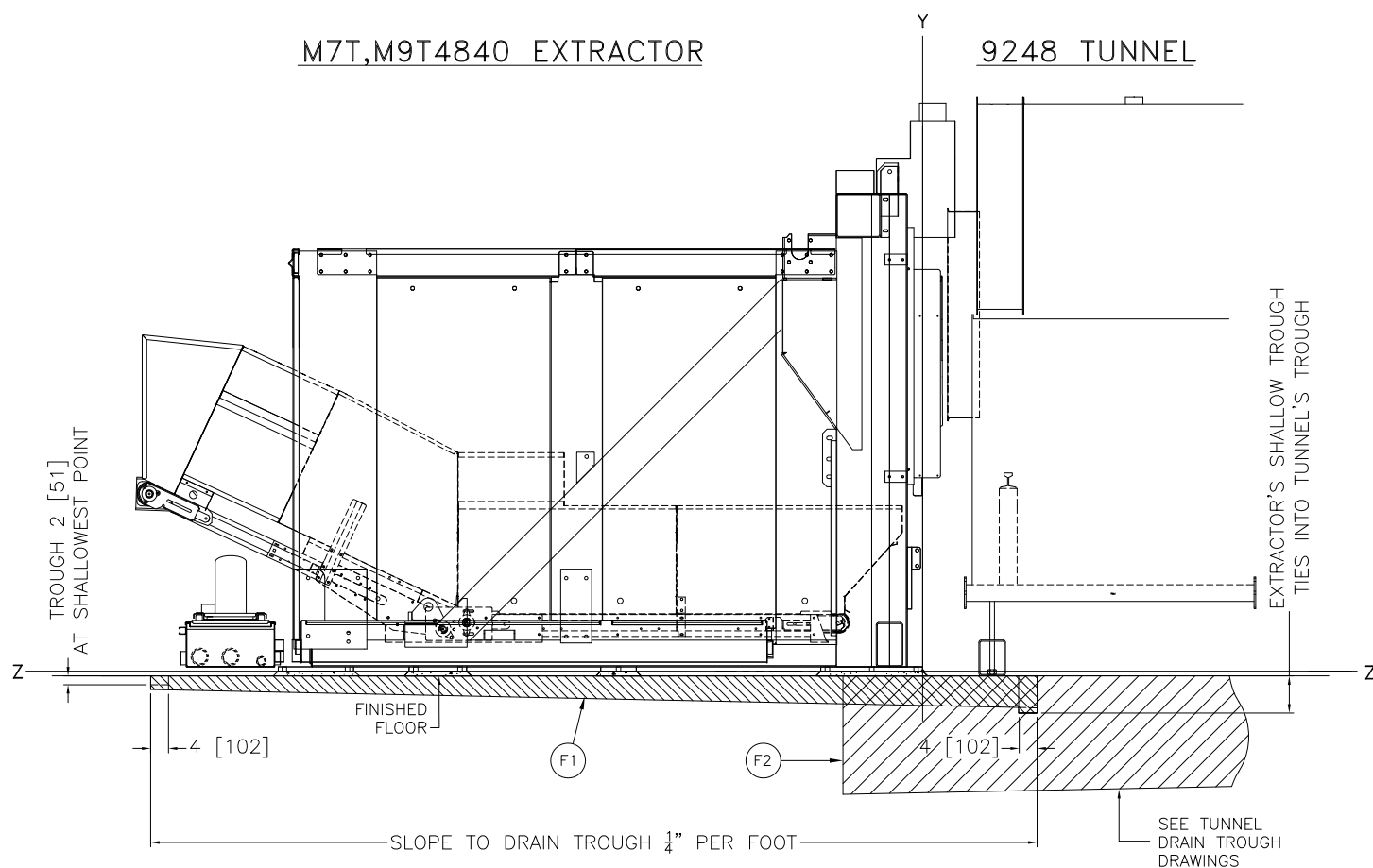
M7T, M9T4840C/36C OPTIONS



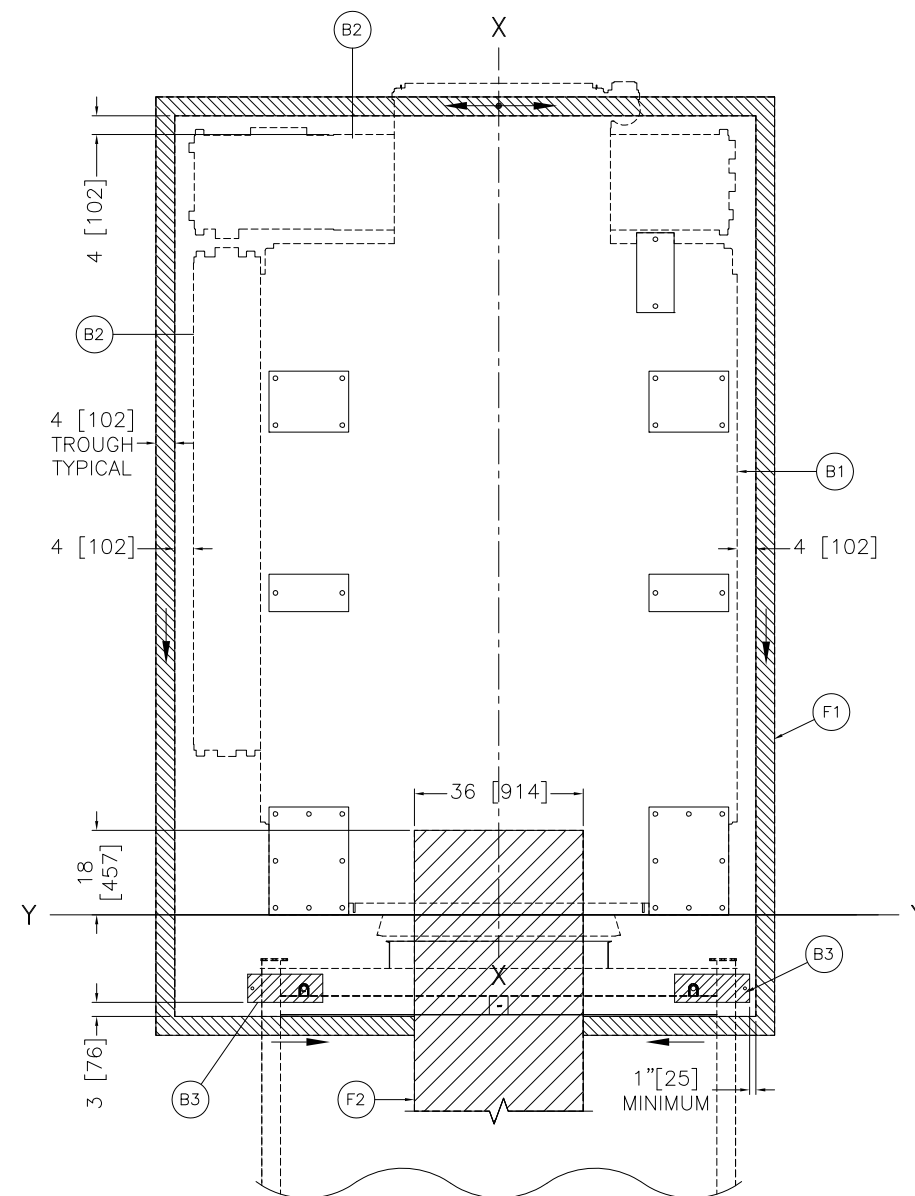
MILNOR PELLERIN MILNOR CORPORATION
P.O. Box 400 Kenner, LA 70063, USA, Phone 504/467-9591,
FAX 504/468-3094, Email: milnorinfo@milnor.com

M7T,M9T4840 EXTRACTOR

9248 TUNNEL



LEFT VIEW



PLAN VIEW

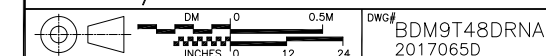
F2	TUNNEL DRAIN TROUGH
F1	EXTRACTOR TROUGH SLOPES TO TUNNEL DRAIN TROUGH
B4	LAST MODULE TUNNEL, BOLT DOWN FEET
B3	EXTRACTOR TANKS (REUSE TANK AND SIDE TANK)
B2	OUTER PERIMETER OF EXTRACTOR HOUSE
B1	TUNNEL DISCHARGE RING
ITEM	LEGEND

- NOTES**
- AS OF THIS WRITING, THE MINIMUM CLEARANCE REQUIRED BY U.S. NATIONAL ELECTRIC CODES, FROM ELECTRIC BOX TO ANY OBJECT IS:
 36 [914] IF OBJECT IS AN UNGROUNDED (INSULATED) WALL.
 42 [1067] IF OBJECT IS A GROUNDED WALL (ie. BARE CONCRETE, BRICK, ETC.)
 48 [1219] IF OBJECT IS ANY LIVE PART.
 CHECK LOCAL ELECTRIC CODES FOR FURTHER RESTRICTIONS.
 - CUSTOMER TO SUPPLY CIRCUIT BREAKER OR FUSED BRANCH CIRCUIT DISCONNECT (SAFETY) SWITCHES WITH LAG TYPE FUSES FROM POWER SOURCE TO MACHINE. A SEPARATE GROUND WIRE MUST BE CONNECTED FROM DISCONNECT TO EQUIPMENT.
 - BASELINE "Z" IS THE SAME FOR ALL MILNOR MACHINES AND IS SHOWN ON ALL DIMENSIONAL DRAWINGS. THE DISTANCE BETWEEN BASELINE "Z" AND THE FINISHED FLOOR MAY VARY (WITH CHANGES IN FLOOR HEIGHT) AS REQUIRED TO INSURE THAT BASELINE "Z" IS HORIZONTAL AND ALL COMPONENTS REQUIRING GROUT ARE SET ON A MINIMUM 1" [25] THICK GROUT BED.
 - USE REFERENCE LINES "X", "Y", AND "Z" TO LOCATE ALL SERVICE CONNECTIONS.
 - NUMBERS IN BRACKETS [] DENOTE DIMENSIONS IN MILLIMETERS.
 - ALL DIMENSIONS SHOWN ARE APPROXIMATE, SUBJECT TO NORMAL MANUFACTURING TOLERANCES, AND TO OCCASIONAL CHANGES WITHOUT NOTICE THROUGH REDESIGN AND/OR RELOCATION OF COMPONENTS, ETC. DO NOT USE FOR CONSTRUCTION UNLESS CERTIFIED, AND IN NO EVENT PRE-PIPE CLOSER THAN FIVE FEET FROM MACHINE. FACTORY MUST BE CONSULTED FOR DIMENSIONS IF MACHINE IS TO BE MOVED THROUGH NARROW OR LOW CORRIDORS OR OPENINGS.

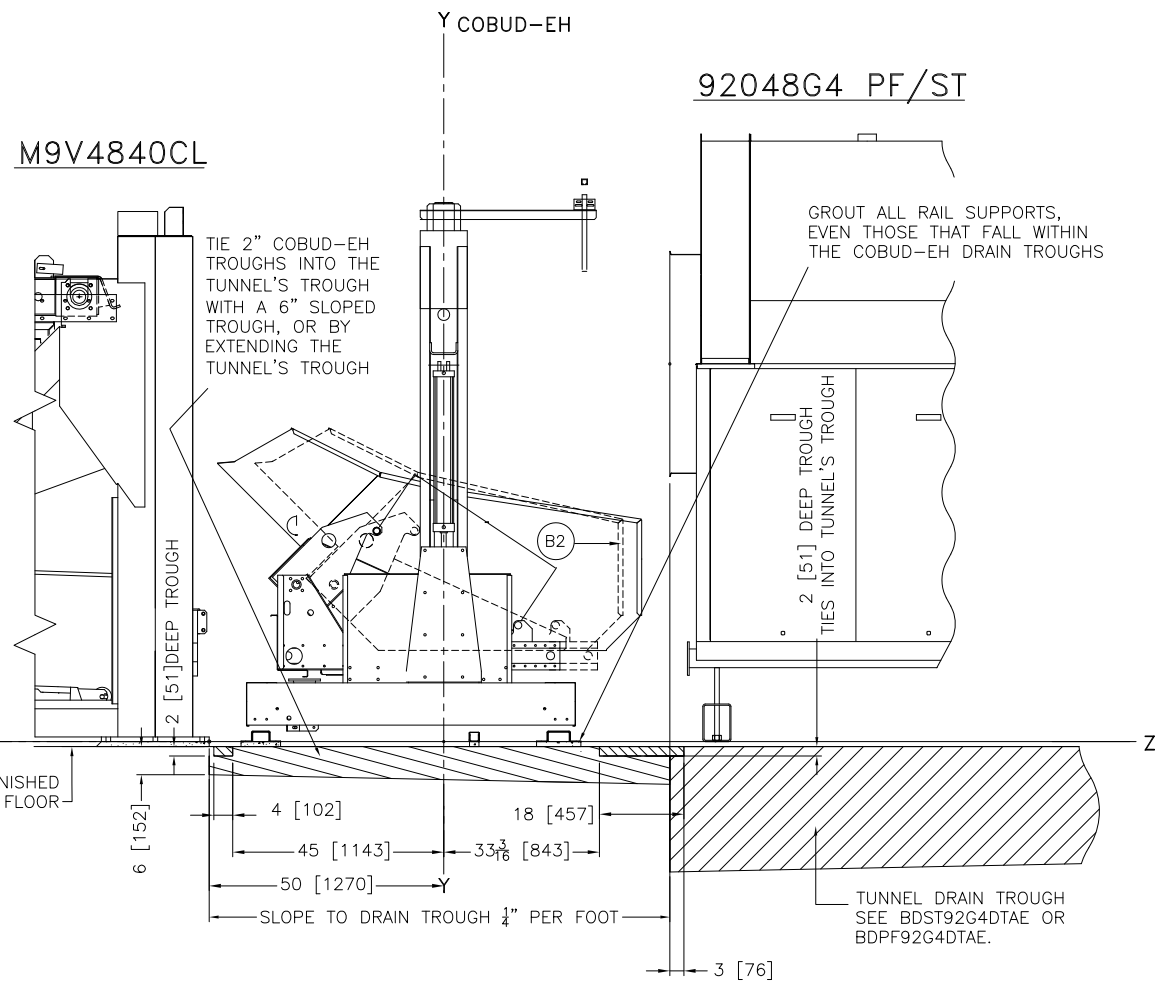
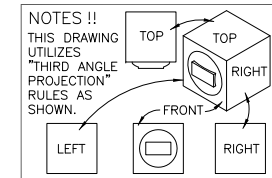
ATTENTION
 MOST REGULATORY AUTHORITIES (INCLUDING OSHA IN THE USA) HOLD THE OWNER/USER ULTIMATELY RESPONSIBLE TO MAINTAIN A SAFE WORKING ENVIRONMENT. ACCORDINGLY, THE OWNER/USER MUST RECOGNIZE ALL FORESEEABLE SAFETY HAZARDS, FURNISH SAFETY INSTRUCTIONS AND GUIDANCE TO ALL PERSONNEL WHO MAY COME IN CONTACT WITH THE INSTALLATION, AND PROVIDE ALL NECESSARY ADDITIONAL SAFETY GUARDS, FENCES, RESTRAINTS, DEVICES, ETC., NOT FURNISHED BY THE EQUIPMENT MANUFACTURER OR VENDOR.

ATTENTION
 THE FLOOR AND/OR OTHER SUPPORT COMPONENTS MUST HAVE SUFFICIENT STRENGTH (AND RIGIDITY WITH DUE CONSIDERATION FOR NATURAL OR RESONANT FREQUENCY THEREOF) TO WITHSTAND THE FULLY LOADED WEIGHT OF THE MACHINE INCLUDING THE GOODS, THE WATER, AND ANY REPEATED SINUSOIDAL (ROTATING) FORCES GENERATED DURING ITS OPERATION. WRITE THE FACTORY FOR ADDITIONAL MACHINE DATA FOR USE BY A COMPETENT SOIL AND/OR STRUCTURAL ENGINEER.

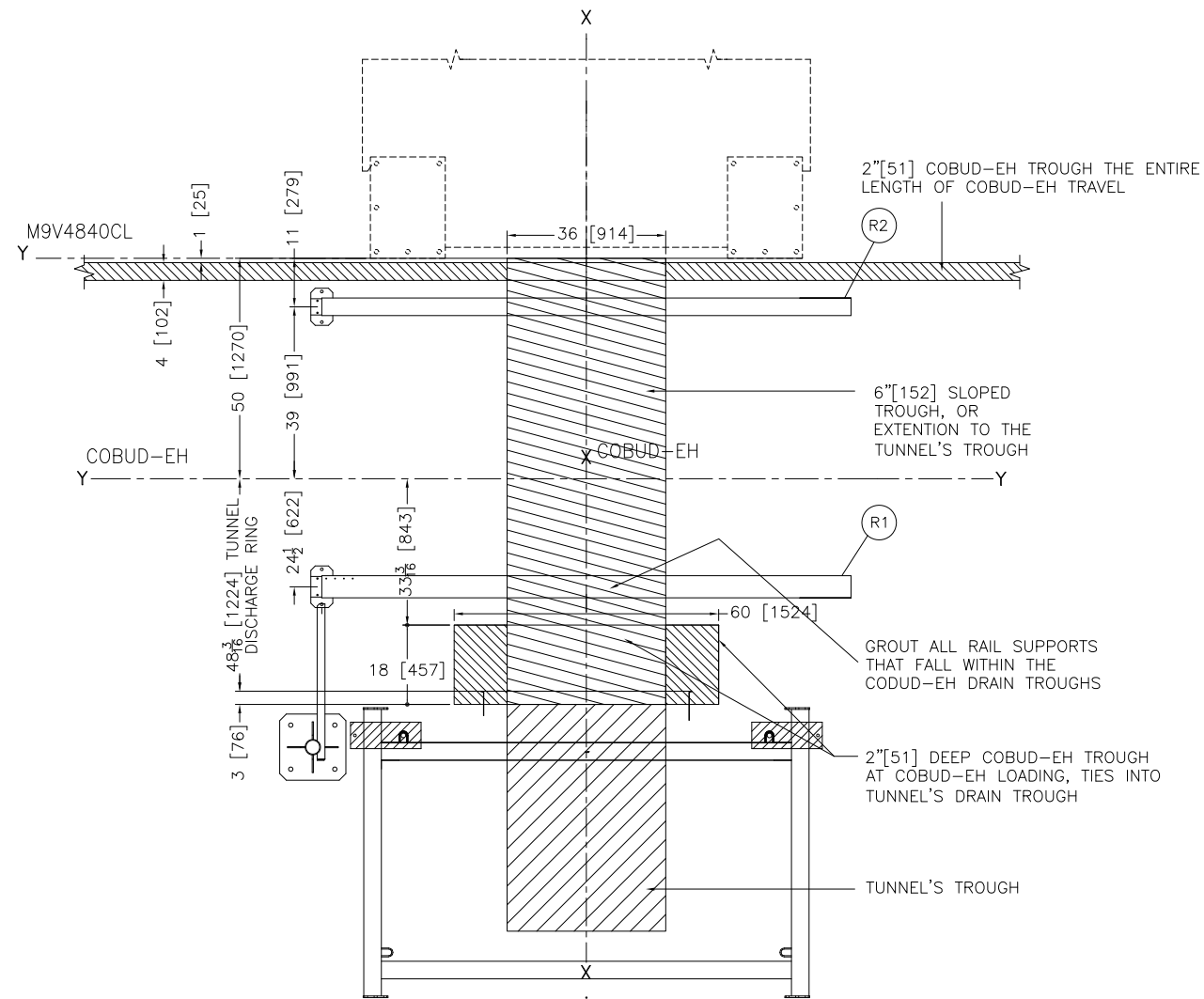
M7T/M9T4840 DRAIN TROUGH



MILNOR PELLERIN MILNOR CORPORATION
 P.O. Box 400 Kenner, LA 70063, USA, Phone 504/467-9591, FAX 504/468-3094, Email: milnorinfo@milnor.com



LEFT VIEW
COBUD-EH DRAIN TROUGHS



PLAN VIEW
COBUD-EH & 9248G4
TROUGHS

R2	4" FLOOR DRIVE RAIL, DISCHARGE SIDE
R1	5" FLOOR DRIVE RAIL, LOAD SIDE
ITEM	LEGEND

NOTES

6 AS OF THIS WRITING, THE MINIMUM CLEARANCE REQUIRED BY U.S. NATIONAL ELECTRIC CODES, FROM ELECTRIC BOX TO ANY OBJECT IS:
 36 [914] IF OBJECT IS AN UNGROUNDED (INSULATED) WALL
 42 [1067] IF OBJECT IS A GROUNDED WALL (ie. BARE CONCRETE, BRICK, ETC.)
 48 [1219] IF OBJECT IS ANY LIVE PART.
 CHECK LOCAL ELECTRIC CODES FOR FURTHER RESTRICTIONS.

5 CUSTOMER TO SUPPLY CIRCUIT BREAKER OR FUSED BRANCH CIRCUIT DISCONNECT (SAFETY) SWITCHES WITH LAG TYPE FUSES FROM POWER SOURCE TO MACHINE. A SEPARATE GROUND WIRE MUST BE CONNECTED FROM DISCONNECT TO EQUIPMENT.

4 BASELINE "Z" IS THE REFERENCE FOR ALL VERTICAL DIMENSIONS. ON MACHINES WITH FIXED BASE PADS, BASELINE "Z" CORRESPONDS TO THE BOTTOM OF THE BASE PAD. ON MACHINES WITH ADJUSTABLE FEET, BASELINE "Z" CORRESPONDS TO THE BOTTOM OF THE FEET WHEN ADJUSTED SO THAT THE MACHINE IS AT ITS MINIMUM ACCEPTABLE HEIGHT. ON TRAVELING SHUTTLES, BASELINE "Z" CORRESPONDS TO THE BOTTOM OF THE BOTTOM RAIL. THE DISTANCE BETWEEN BASELINE "Z" AND THE FINISHED FLOOR WILL VARY AS REQUIRED TO ENSURE BASELINE "Z" IS HORIZONTAL AND ANY INTERFACING MACHINES REQUIRING GROUT ARE SET ON A MINIMUM 1[25] THICK GROUT BED.

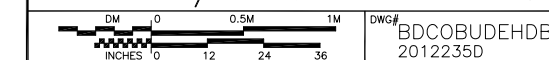
3 USE REFERENCE LINES "X", "Y", AND "Z" TO LOCATE ALL SERVICE CONNECTIONS.
 2 NUMBERS IN BRACKETS [] DENOTE DIMENSIONS IN MILLIMETERS.

1 ALL DIMENSIONS SHOWN ARE APPROXIMATE, SUBJECT TO NORMAL MANUFACTURING TOLERANCES, AND TO OCCASIONAL CHANGES WITHOUT NOTICE THROUGH REDESIGN AND/OR RELOCATION OF COMPONENTS, ETC. DO NOT USE FOR CONSTRUCTION UNLESS CERTIFIED, AND IN NO EVENT PRE-PIPE CLOSER THAN FIVE FEET FROM MACHINE. FACTORY MUST BE CONSULTED FOR DIMENSIONS IF MACHINE IS TO BE MOVED THROUGH NARROW OR LOW CORRIDORS OR OPENINGS.

ATTENTION
 MOST REGULATORY AUTHORITIES (INCLUDING OSHA IN THE USA) HOLD THE OWNER/USER ULTIMATELY RESPONSIBLE TO MAINTAIN A SAFE WORKING ENVIRONMENT. ACCORDINGLY, THE OWNER/USER MUST RECOGNIZE ALL FORESEEABLE SAFETY HAZARDS, FURNISH SAFETY INSTRUCTIONS AND GUIDANCE TO ALL PERSONNEL WHO MAY COME IN CONTACT WITH THE INSTALLATION, AND PROVIDE ALL NECESSARY ADDITIONAL SAFETY GUARDS, FENCES, RESTRAINTS, DEVICES, ETC., NOT FURNISHED BY THE EQUIPMENT MANUFACTURER OR VENDOR.

ATTENTION
 THE FLOOR AND/OR OTHER SUPPORT COMPONENTS MUST HAVE SUFFICIENT STRENGTH (AND RIGIDITY WITH DUE CONSIDERATION FOR NATURAL OR RESONANT FREQUENCY THEREOF) TO WITHSTAND THE FULLY LOADED WEIGHT OF THE MACHINE INCLUDING THE GOODS, THE WATER, AND ANY REPEATED SINUSOIDAL (ROTATING) FORCES GENERATED DURING ITS OPERATION. WRITE THE FACTORY FOR ADDITIONAL MACHINE DATA FOR USE BY A COMPETENT SOIL AND/OR STRUCTURAL ENGINEER.

COBUD-EH/9248G4 DRAIN TROUGH



MILNOR PELLERIN MILNOR CORPORATION
 P.O. Box 400 Kenner, LA 70063, USA, Phone 504/467-9591
 FAX 504/469-1849, Telex IT 460124/PELM UI, Cable PELMILNOR