

30022 VZZ

60 LB. (27KG) CAPACITY
RIGID-MOUNT WASHER-EXTRACTOR

SPECIFICATION SHEET

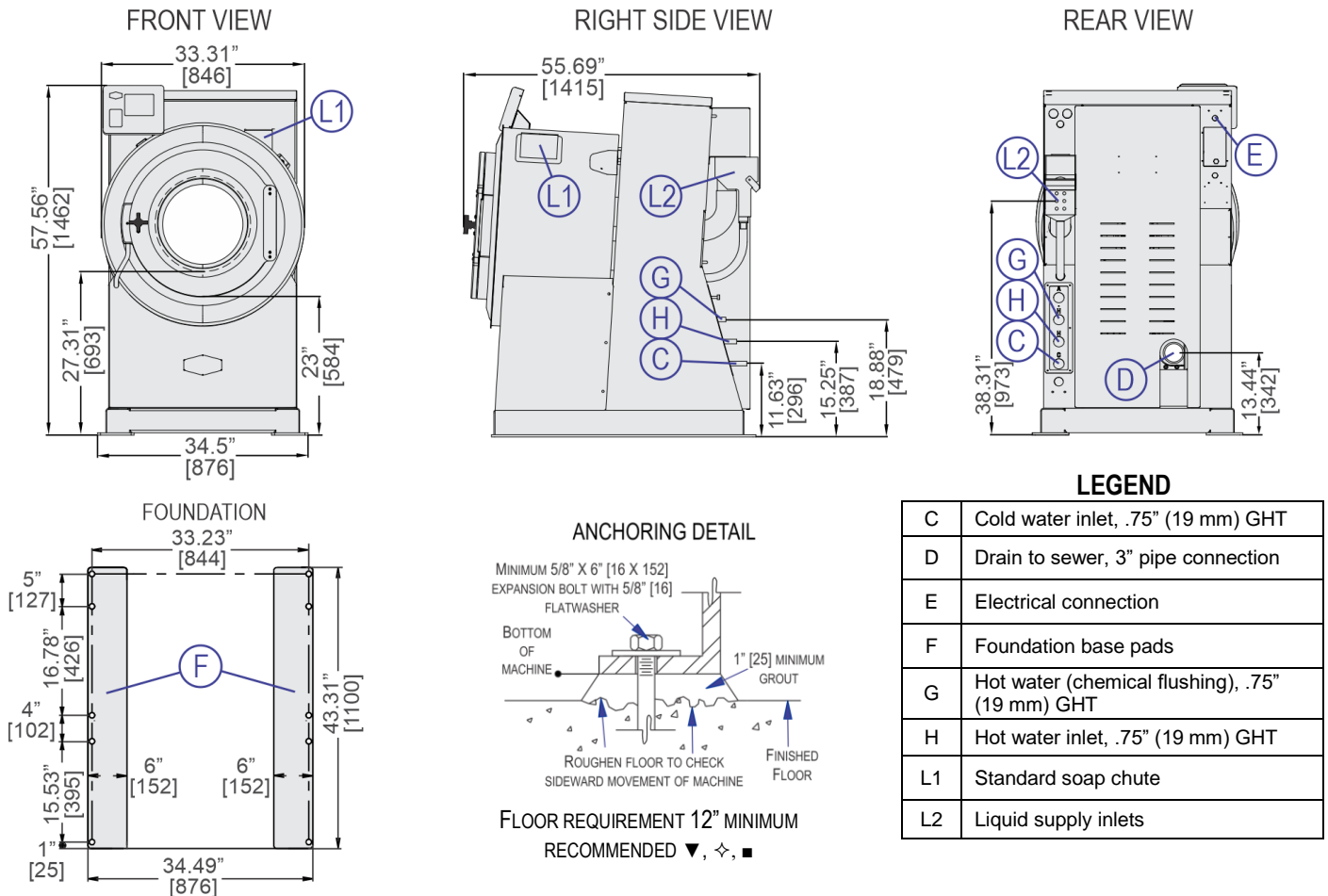

MECHANICAL SPECIFICATIONS

Capacity – lb. (kg)	60 (27)
Cylinder Diameter x Depth – in. (mm)	30 x 22 (762 x 559)
Door Opening – in. (mm)	15.5 (394)
Cylinder Volume – cu. ft. (L)	9 (255)
Machine Dimensions (W x D x H) – in. (mm)	34.5 x 55.69 x 57.56 (876 x 1415 x 1462)
Shipping Dimensions (W x D x H) – in. (mm)	40 x 64 x 63 (1016x1625x1600)
Motor – HP (kW)	6 (4.47)
Wash Speeds – RPM	30-46
Distribution Speed – RPM	99
Extraction Speeds – RPM	200-969
Extraction G-Force*	400*
Static Weight – lb. (kg) ◇	1344 (610)
Max. Dynamic Load RMS – lb. (kg) ◇	3180 (1442)
Frequency (Hz)	16.15
Water Pressure (Required) – psi (bar)	10-75 (.68-5.1)
Water Valve Cv Rating at 72°F (22°C)	5.8 (22)
Minimum Recommended Distance Between Machines – in. (mm)	6 (152)

*For balanced loads; out of balance loads could result in lower extraction G-Force

ELECTRICAL SPECIFICATIONS

Voltage	Running Amps	Fuse (Amps)	Circuit Breaker (Amps)
220/3/50-60	7	FRN20	20
208, 240/1/60	18/16	FRN25	25
208, 240/3/60	8, 7	FRN20	20
380/3/50-60	4.5	FRS15	15
415/3/50	4.5	FRS15	15
480/3/60	3.5	FRS15	15

See Fuse and Wire Size manual MAEFUSE 1BE for safety information. Contact factory for electrical specifications if equipped with Electric Heat option. Contact factory for single phase availability.

▼ See dimensional drawing for complete details.

◇ It is the sole responsibility of the owner/user to assure that the floor and/or any other supporting structure exceeds not only all applicable building codes, but also that the floor and/or any other supporting structure for each washer-extractor or group of washer-extractors has sufficient strength and rigidity (i.e., a natural or resonant frequency many times greater than the rotational machine speed with a reasonable factory of safety) to support the weight of all the fully loaded machine(s) including the weight of the water and goods, and including the published 360° rotating sinusoidal RMS forces that are transmitted by the machine(s). Contact the factory for additional machine data for use by a structural engineer.

■ Machine bases made from concrete should either be part of a monolithic pour or should be tied into foundation and not isolated from existing floor.



30022 VZZ

60 LB. (27KG) CAPACITY

RIGID-MOUNT WASHER-EXTRACTOR

SPECIFICATION SHEET

Standard Features:

- RinSave® water saving technology
- 7 speeds (2 wash, 1 distribution, 1 RinSave, 3 extract)
- 400G high speed extract
- MilTouch™ touch screen controller
- Single-motor inverter drive
- Tall, lifting ribs
- Tapered roller bearings
- High M.A.F. (Mechanical Action Factor)
- Large cylinder perforations
- Fresh-water flushing chemical manifold
- Auto tension V-belt drive
- Six (6) liquid chemical injection ports
- Control is configurable to display your choice of language
- 5-year limited warranty on frame, cylinder & shell



Optional Features:

- Steam
- 3 compartment flushing supply injector
- Prison package

Why Purchase Milnor?

- Larger cylinder volume than most competitive similar sized washer-extractors provides *greater productivity*. More linen washed per day, or fewer hours required to process. **BENEFIT: Saves labor.**
- Greater cylinder perforated-area generates *better wash quality, better rinsing and better extraction*. **BENEFIT: Better extraction saves dryer fuel.**
- Faster process times reduce fabric wear, promoting *longer linen life!* **BENEFIT: Saves linen replacement costs.**
- High perforated ribs provide excellent lifting. **BENEFIT: Greater mechanical action leads to better wash quality.**
- High extract provides excellent moisture removal. Lower extract speeds are available for uniforms, delicate textiles and blended fabrics. **BENEFIT: Better extraction saves dryer fuel.**
- MilTouch™ touch screen control, utilizing resistive touch screen technology and full VGA resolution, has a clear and informative display which shows current machine status info including total formula time and time elapsed. Formulas can be developed on a PC, saved to USB external memory and uploaded with a screen touch. Controller also provides intuitive fault diagnosis and relevant troubleshooting suggestions. **BENEFIT: Fewer operator errors.**
- Superior product support through local, highly-skilled dealers. **BENEFIT: Faster repairs mean less downtime.**



Safe chemical injection



Superior cylinder design

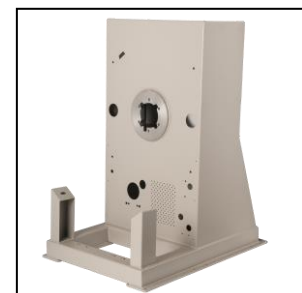

Solid industrial frame

Contact Milnor for your local, authorized dealer:

Pellerin Milnor Corporation
P.O. Box 400 • Kenner, LA 70063
t: 504-467-9591 • f: 504-468-3094

