

# M30C

## 30-lb Capacity Coin Dryer

### Standard Features:

- 30-lb. capacity
- 12.5 cu. ft basket volume
- 100,000 btu/hr heat input, 460 cfm. airflow
- Radial airflow
- Steel door with gasketless glass
- Easy access to lint compartment
- Fits through a standard 36" door
- Available in gas, steam and electric heat

### Optional Features:

- Stainless steel front, cabinet & basket
- Reversing basket
- F.S.S. (Fire Suppression System)



M30C Coin Dryer

## Why Purchase Milnor M30C?

### Engineer Driven Design That is Built to Last

Our dryers showcase an engineer-driven approach to design. Bearings are permanently lubricated on the motor and drive system. There are no chains used; rather, we use V-belts and pulleys for smooth, quiet, and trouble free operation. Our dryer cabinets are electrostatically powder-painted inside and out then baked at 420-degrees fahrenheit before final assembly - ensuring the hardest surface and the longest lasting finish in the industry.

### Rugged Steel Door with Gasketless Door Glass

Our dryer doors are one solid piece of steel with gasketless glass. This eliminates the issue of glass falling out due to wear and tear on rubber gaskets that some manufacturers use to secure their glass. The security and durability that gasketless glass provides is essential to a successful laundry operation.

### Easy-to-Read, Multilingual Controls

Our dryers were one of the first computer operated dryers on the market and we continue to apply innovative technology to dryer operation. Our accessible design, easy-to-read LED screens and our user friendly multilingual interface positions Milnor as a leader in the laundry industry.

Your local Milnor independent authorized dealer.



# M30C

## M30C Specifications

Tumbler Capacity (dry weight)	30 lbs. (13.6 kg)
Tumbler Diameter	32-3/4" (83.2 cm)
Tumbler Depth	25-5/8" (65.1 cm)
Tumbler Volume	12.5 cu ft (353.96 L)
Tumbler/Drive Motor (nonreversing/reversing)	1/2 hp (0.37 kW) / 1/2 hp (0.37kW)
Blower/Fan Motor (nonreversing/reversing)	N/A / 1/2 hp (0.37kW)
Door Opening (Diameter)	21-1/2" (54.61 cm)
Door Sill Height	33-1/8" (84.15 cm)
F.S.S. Water Connection	North America Outside North America
	3/4"-11.5 N.H. 3/4" B.S.P.T.
Dryers per 20'/40' Container	12 / 26
Dryers per 48'/53' Truck	30 / 32
Width	34-1/4" (87 cm)
Depth	38" (96.5 cm)
Height	72" (182.8 cm)
Airflow gas/electric/steam	60 Hz 50 Hz
	460 cfm (13 cmm) 383 cfm (10.85 cmm)
Exhaust Connection	8" (20.32 cm)
GAS MODEL:	
Approx. Net Wt.	534 lbs (242 kg)
Approx. Ship Wt.	571 lbs (259 kg)
Heat Input	100,000 btu/hr (25,200 kcal/hr)
Inlet Pipe Connection	1/2" M.N.P.T. 1/2" B.S.P.T. (CE and Australia Only)
ELECTRIC MODEL:	
Approx. Net Wt.	534 lbs (242 kg)
Approx. Ship Wt.	571 lbs (259 kg)
Oven Size	
kW	Btu/hr (kcal/hr)
20	68,200 (17,200)
24	81,900 (20,600)
Steam MODEL:	
Approx. Net Wt.	593 lbs. (269 kg)
Approx. Ship Wt.	631 lbs. (286 kg)
Steam Consumption	104 lb/hr (47.2 kg/hr)
Operating Steam Pressure	125 psi max (8.6 bar)
Boiler Horsepower (Normal Load)	3.0 Bhp
Supply Connection	1" F.N.P.T.
Return Connection	1" F.N.P.T.

Specifications in parentheses are metric equivalents.

REV 5/3/12

\*\* Reversing dryer available with 3-phase (3ø) 1/2 hp (0.373kW) motor standard

\*\*\*Specify air operated or electromechanical steam damper system. Air-operated steam damper system must be provided with clean, dry and regulated 80 psi ± 10 psi (5.51 bar ± 0.68 bar) air supply.

REAR VIEW (STEAM ONLY)

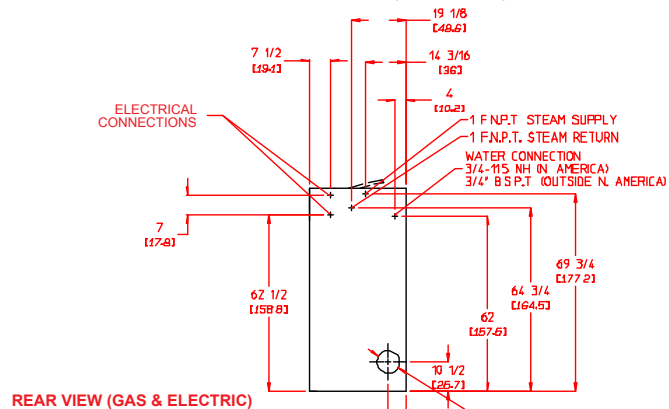

REAR VIEW (GAS & ELECTRIC)

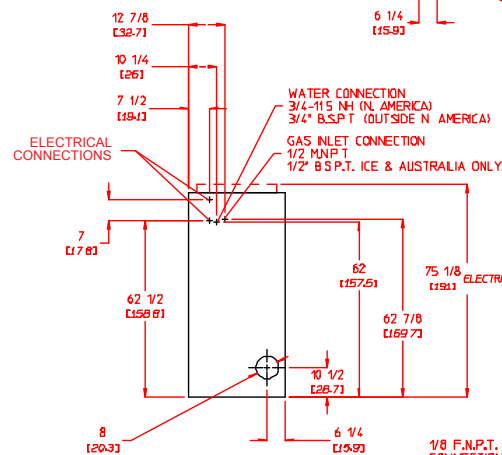

FRONT VIEW

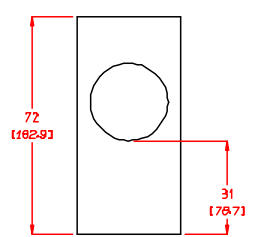

PLAN VIEW

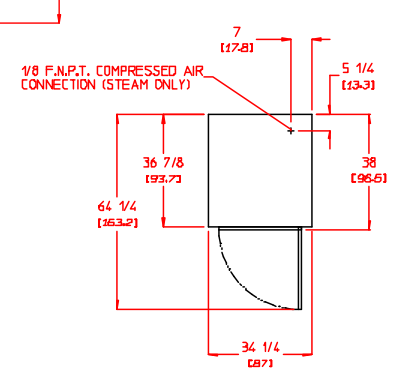

### Electrical Service Specifications

SERVICE VOLTAGE	PHASE	WIRE SERVICE	APPROX AMP DRAW		CIRCUIT BREAKER
			60 Hz	50 Hz	
GAS & STEAM (non-reversing)					
120	1ø	2	8.7	--	15
208	1ø	2	5.5	--	15
220	1ø	2	4.5	3.9	15
230	1ø	2	--	3.5	15
240	1ø	2	4.8	4.6	15
208	3ø	3	3.1	--	15
240	3ø	3	3.3	4.2	15
380	3ø	4*	--	2.2	15
400	3ø	4*	--	2.2	15
416	3ø	4*	--	2.3	15
460	3ø	3	2.1	--	15
480	3ø	3	2.1	--	15
GAS & STEAM (reversing)					
208	3ø	3	5.0	--	15
220	3ø	3	5.2	6.8	15
240	3ø	3	5.6	7.4	15
380	3ø	4*	--	3.4	15
400	3ø	4*	--	3.4	15
416	3ø	4*	--	3.6	15

### Electrical Service Specifications

SERVICE VOLTAGE	PHASE	WIRE SERVICE	APPROX AMP DRAW		CIRCUIT BREAKER
			60 Hz	50 Hz	
20 kW Electric					
208	1ø	2	102	--	150
220	1ø	2	97	--	125
230	1ø	2	92	--	125
240	1ø	2	88	88	125
380	3ø	4*	--	35	50
380	3ø	3	36	--	50
208	3ø	3	61	--	80
24 kW Electric					
208	1ø	2	121	--	150
208	3ø	3	72	--	90
220	3ø	3	--	60	80
230	3ø	3	--	60	80
240	3ø	3	63	62	80
380	3ø	3	41	--	60
380	3ø	4	71	--	90
380	3ø	4*	--	43	60
416	3ø	4*	--	38	50



Pellerin Milnor Corporation, PO Box 400, Kenner, LA 70063 USA,  
Phone 504.712.7656 Toll Free: 800.469.8780 Fax: 504.468.3094

www.milnor.com