

# M333

## 30-lb x 2 Capacity OPL Dryer

### Standard Features:

- 30-lb. x 2 capacity
- 10.1 cu. ft. volume
- 72,000 Btu/hr heat input, 400 cfm airflow per pocket
- Partial axial airflow
- Steel door with gasketless glass
- Single 8" diameter top exhaust connection
- 1/2" gas connection per pocket
- Fits through a standard 36" door
- Available in gas heat
- Available in gray, white and stainless steel front and cabinet

OPL  
OPL



M333 OPL Stack Dryer

### Why Purchase Milnor M333?

#### Engineer Driven Design That is Built to Last



Our dryers showcase an engineer-driven approach to design. Bearings are permanently lubricated on the motor and drive system. There are no chains used; rather, we use V-belts and pulleys for smooth, quiet, and trouble free operation. Our dryer cabinets are electrostatically powder-painted inside and out then baked at 420-degrees fahrenheit before final assembly - ensuring the hardest surface and the longest lasting finish in the industry.

#### Rugged Steel Door with Gasketless Door Glass

Our dryer doors are one solid piece of steel with gasketless glass. This eliminates the issue of glass falling out due to wear and tear on rubber gaskets that some manufacturers use to secure their glass. The security and durability that gasketless glass provides is essential to longevity.

#### More for Less

The M333 incorporates all the state-of-the-art design features from the leader in stack dryer design-with simple controls, an easy-to-read LED screen and a large lightweight lint drawer that is accessible and easy to clean--only requiring cleaning once a day. It's fine stainless steel lint screen is standard. Available for coin or card ready, the M333 gives you all the benefits of Milnor quality engineering at a low cost.

Your local Milnor independent authorized distributor



# M333

M333 Specifications	
Tumbler Capacity (dry weight)	30 lbs. (13.60 kg) x 2
Tumbler Diameter	27-1/4" (69.21 cm)
Tumbler Depth	30" (76.20 cm)
Tumbler Volume	10.1 cu ft (286 L)
Tumbler/Drive Motor	1/2 hp (0.37 kW)
Blower/Fan Motor	N/A
Door Opening (Diameter)	21-1/2" (54.61 cm)
Door Sill Height	top pocket: 52-7/8" (134.3 cm) bottom pocket: 14-1/4" (36.2 cm)
Dryers per 20'/40' Container	11 / 22
Dryers per 48'/53' Truck	30 / 33
Width	29-3/4" (75.4 cm)
Depth	53" (134.5 cm)
Height	78-1/4" (198.8 cm)
Airflow	60 Hz: 400 cfm (11.3 cmm) 50 Hz: 340 cfm (9.6 cmm)
Exhaust Connection	8" (20.32 cm)
GAS MODEL:	Voltage Available: 120-240v 1,3ø 2,3w Approx. Net Wt.: 675 lbs (306 kg) Approx. Ship Wt.: 710 lbs (322 kg) Heat Input (per pocket): 72,000 btu/hr (18,143 kcal/hr) Inlet Pipe Connection (per pocket): 1/2" F.N.P.T.

Specifications in parentheses are metric equivalents.

REV 10/18/13

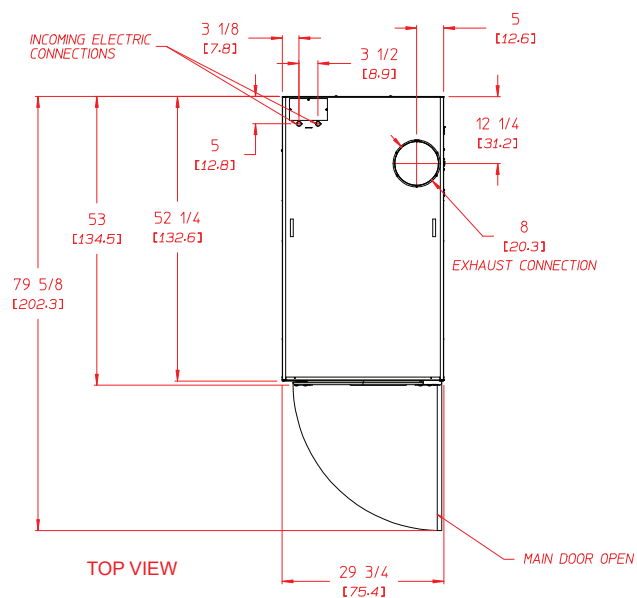
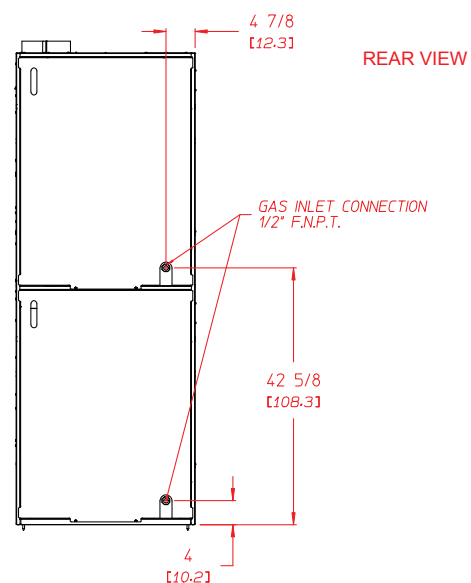
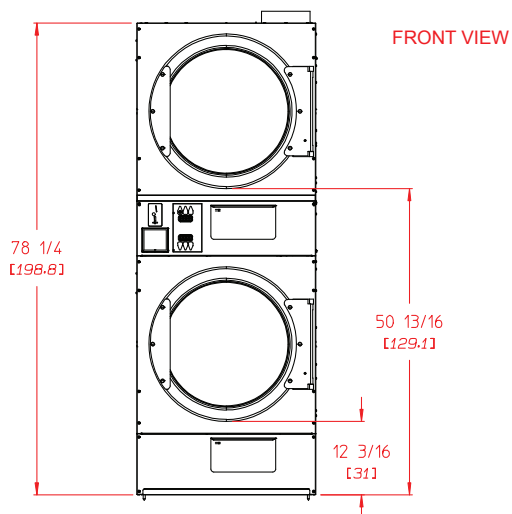

Electrical Service Specifications					
GAS					
SERVICE VOLTAGE	PHASE	WIRE SERVICE	APPROX AMP DRAW		CIRCUIT BREAKER
			60 Hz	50 Hz	
120	1ø	2	8.7	--	15
208	1ø	2	5.2	--	15
240	1ø	2	4.8	--	15



Pellerin Milnor Corporation, PO Box 400, Kenner, LA 70063 USA  
Phone 504.712.7656 Toll Free: 800.469.8780 Fax: 504.468.3094

www.milnor.com