

MWS26Z

55 lb. (26 kg) Capacity

Aseptic Barrier Washer-Extractor Specification Sheet



milnor.com



STANDARD FEATURES:

- Aseptic barrier system
- StaphAIRTROL prevents air from being recirculated
- MilTouch™ programmable controller
- Frequency controlled drive motor
- Air-operated valves
- Programmable overnight bath soak
- Programmable water temperature for each bath
- Programmable air-operated steam injection
- Side-loaded open pocket basket
- Eight (8) liquid chemical injection ports
- Control is configurable to display language of choice



OPTIONAL FEATURES:

- Air-operated reuse inlet and drain

Why Purchase Milnor?

BENEFIT: Saves water, energy and time. RinSave® water saver eliminates up to two rinses per load, providing more efficient rinsing.

BENEFIT: Reduces objectionable vibration. The MWS-Series incorporates air bags and shock absorbers for its suspension system, limiting vibration.

BENEFIT: Promotes consistency and allows flexibility. 8 liquid chemical ports, 6 signals, and single pocket dry powder soap chute.

BENEFIT: Saves linen replacement costs. Faster process times reduce fabric wear, promoting longer linen life!

BENEFIT: Efficient operation. Safe, simple-to-use inner and outer door interlocks allow operators to easily access the inner drum for loading and unloading the machine.

BENEFIT: Better extraction saves dryer fuel. High extract provides excellent moisture removal. Lower extract speeds are available for uniforms, delicate textiles and blended fabrics.

BENEFIT: Fewer operator errors. • MilTouch™ touch screen control, utilizing resistive touch screen technology and full VGA resolution, has a clear and informative display which shows current machine status info including total formula time and time elapsed. Formulas can be developed on a PC, saved to USB external memory and uploaded with a screen touch. Controller also provides intuitive fault diagnosis and relevant troubleshooting suggestions.

BENEFIT: Faster repairs mean less downtime. Superior product support through local, highly-skilled dealers.



StaphAIRTROL



Advanced control



Superior cylinder design

Contact Milnor for your local, authorized dealer:

PELLERIN MILNOR CORPORATION

P.O. Box 400, Kenner, LA 70063 • t: 504-467-9591 • milnorinfo@milnor.com

MWS26Z

55 lb. (26 kg) Capacity

Aseptic Barrier Washer-Extractor Specification Sheet



milnor.com

LEGEND

A	Compressed air inlet, .5" (13mm) NPT
C	Cold water inlet, .75" (19 mm) NPT
D	Drain valve, 3" (76 mm)
F	Foundation pads
G	Hot water (chemical flushing) .75" (19mm) NPT
H	Hot water inlet, .75" (19mm) NPT
L1	Soap Chute
L2	Peristaltic supply connection
S	Steam inlet connection, .5" (13mm) NPT

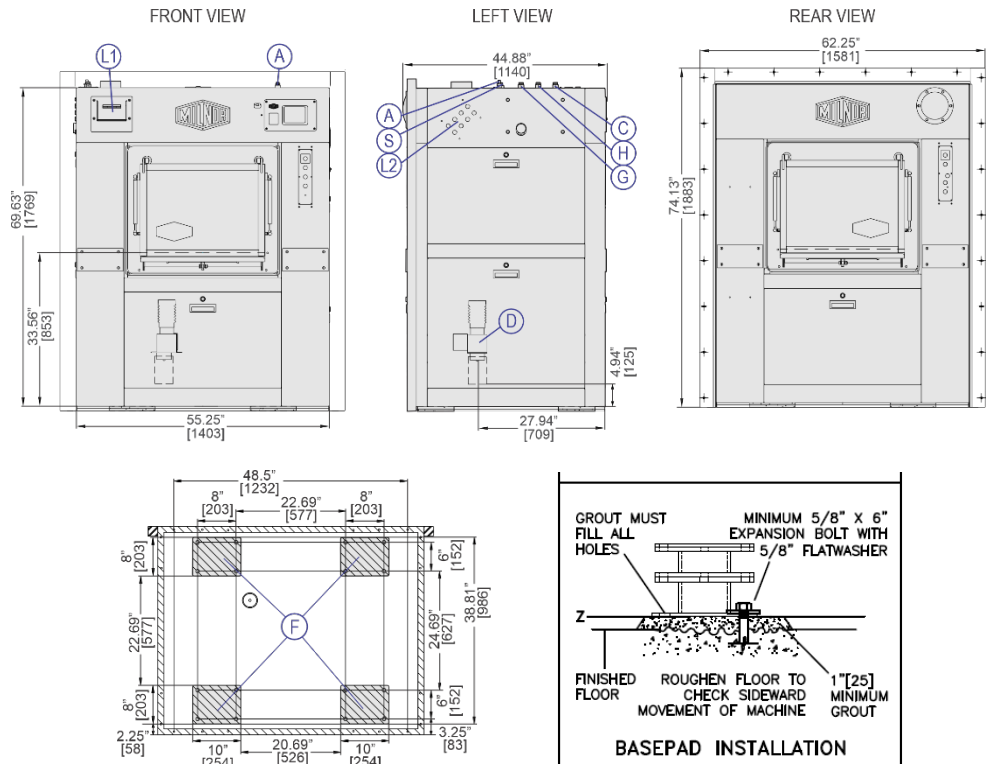

MECHANICAL SPECIFICATIONS

Capacity – lb. (kg)	55 (26)
Cylinder Diameter x Depth – in. (mm)	31.5 x 23.6 (800 x 599)
Cylinder Volume – cu. ft. (L)	9 (254.8)
Door opening – in (mm)	22.8 x 11.4 (579 x 289)
Machine Dimensions (W x D x H) – in. (mm)	55.25 x 43.25 x 69.63 (1403 x 1099 x 1769)
Shipping Dimensions (W x D x H) – in. (mm)	62 x 48 x 76 (1575 x 1219 x 1930)
Motor – HP (kW)	6 (4.47)
Wash Speed – RPM	39
Distribution Speed – RPM	67
Extraction Speed – RPM	819
Extraction G-Force – for balanced loads	300
Static Weight – lb. (kg)♦	2037 (924)
Max. Dynamic Load RMS – lb. (kg)♦	344 (156)
Frequency - Hz♦	13.65
Water Pressure ^(Required) – psi (bar)	29-87 (2-6)
Water Valve - Cv Rating at 72°F (22°C)	9.8

Specifications and appearance subject to change without notification.
B22SS25006/26106

ELECTRICAL SPECIFICATIONS

Voltage	Fuse (Amps)	Circuit Breaker (Amps)
208/3/60	FRN35	35
220/3/50-60	FRN35	35
240/3/60	FRN30	30
380/3/50-60	FRS20	20
480/3/60	FRS15	15

See Fuse and Wire Size manual MAEFUSE1BE for safety information. Contact factory regarding single phase availability.

▲ See dimensional drawing for complete details.

♦ It is the sole responsibility of the owner/user to assure that the floor and/ or any other supporting structure exceeds not only all applicable building codes, but also that the floor and/ or any other supporting structure for each washer-extractor or group of washer-extractors has sufficient strength and rigidity (i.e., a natural or resonant frequency many times greater than the rotational machine speed with a reasonable factory of safety) to support the weight of all the fully loaded machine(s) including the weight of the water and goods, and including the published 360° rotating sinusoidal RMS forces that are transmitted by the machine(s). Contact the factory for additional machine data for use by a structural engineer.

■ Machine bases made from concrete should either be part of a monolithic pour or should be tied into foundation and not isolated from existing floor.