

MWT18X4

45 LB. (20KG) CAPACITY
RIGID-MOUNT WASHER-EXTRACTOR

SPECIFICATION SHEET

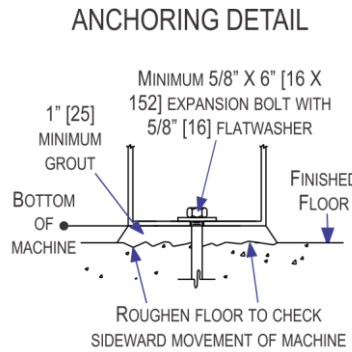
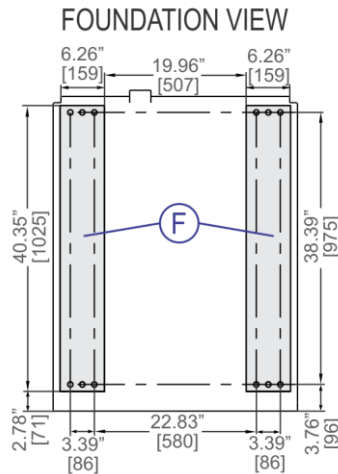
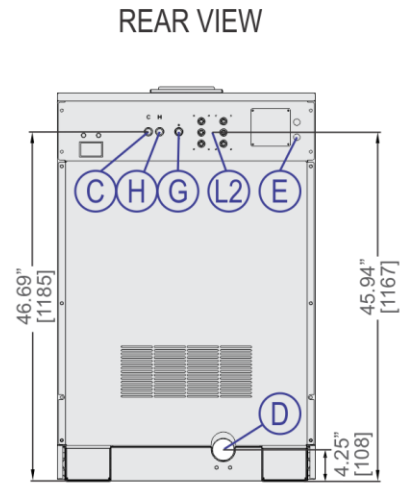
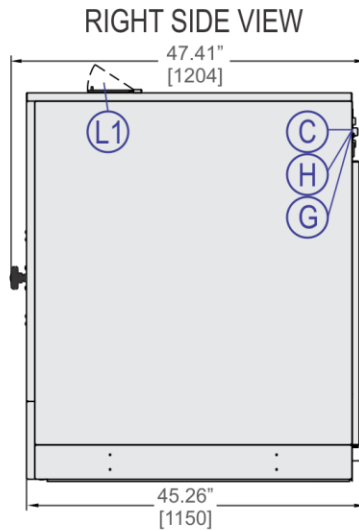
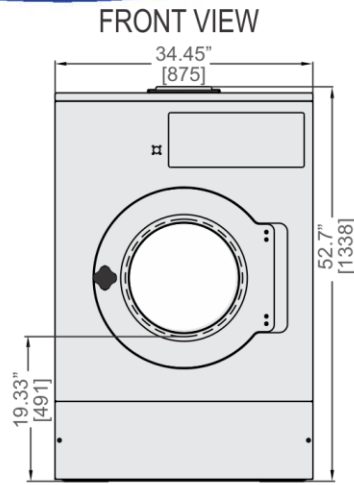

FLOOR REQUIREMENT MINIMUM 6"
RECOMMENDED ◊, ▼, ■

LEGEND

C	Cold water inlet, .75" (19 mm) GHT
D	Drain 3" (76 mm) ID hose connection
E	Main electrical connection
F	Foundation pads; Anchor bolt holes, .8125" (21 mm) diameter
G	Hot water inlet for soap chute
H	Hot water inlet, .75" (19 mm) GHT
L1	Standard soap chute
L2	Liquid supply inlets

MECHANICAL SPECIFICATIONS

Capacity – lb (kg)	45 (20)
Cylinder Diameter x Depth – in (mm)	27.56 x 18.43 (700 x 468)
Cylinder Volume – cu. ft. (L)	6.36 (180)
Door Opening – in (mm)	15.70 (399)
Machine Dimensions (W x D x H) – in (mm)	34.45 x 47.41 x 52.70 (875x1204x1338.5)
Shipping Dimensions (W x D x H) – in (mm)	40.35 x 50.79 x 58.19 (1025 x 1290 x 1478)
Motor – HP (kW)	3 (2.2)
Wash Speed – RPM	39
Distribution Speed – RPM	71
Extraction Speed – RPM	480
Extraction G-Force	90
Static Weight – lb (kg) ◊	1045 (520)
Max. Dynamic Load RMS – lb (kg) ◊	810 (368)
Frequency (Hz)	7.98
Water Pressure (Required) – psi (bar)	10-75 (.68-5.1)
Water Valve CV Rating at 72°F (22°C)	0.68-0.72 (2.57-2.73)
Minimum Recommended Distance Between Machines – in (mm)	0 (0)

ELECTRICAL SPECIFICATIONS

Voltage	Running Amps	Fuse (Amps)	Circuit Breaker (Amps)
220/3/50	7	FRN15	15
208,240/1/60	14/12	FRN20	20
208,240/3/60	9/8	FRN15	15
380/3/50-60	4.5	FRS8	15
415/3/50	4.5	FRS8	15
480/3/60	3.5	FRS5	15

See Fuse and Wire Size manual MAEFUSE1BE for safety information.

▼ See dimensional drawing for complete details.

◊ It is the sole responsibility of the owner/user to assure that the floor and/or any other supporting structure exceeds not only all applicable building codes, but also that the floor and/or any other supporting structure for each washer-extractor or group of washer-extractors has sufficient strength and rigidity (i.e., a natural or resonant frequency many times greater than the rotational machine speed with a reasonable factory of safety) to support the weight of all the fully loaded machine(s) including the weight of the water and goods, and including the published 360° rotating sinusoidal RMS forces that are transmitted by the machine(s). Contact the factory for additional machine data for use by a structural engineer.

■ Machine bases made from concrete should either be part of a monolithic pour or should be tied into foundation and not isolated from existing floor.



MWT18X4

45 LB. (20KG) CAPACITY
RIGID-MOUNT WASHER-EXTRACTOR

SPECIFICATION SHEET

Standard Features:

- 3 speeds
- E-P Express® programmable controller
- Single-motor inverter drive
- Tall, lifting ribs
- Sealed ball bearings
- High M.A.F. (Mechanical Action Factor)
- Large cylinder perforations
- Fresh-water flushing chemical manifold
- Auto tension V-belt drive
- Five (5) liquid chemical injection ports
- Control reads in English/second language
- 5-year limited warranty on frame, cylinder & shell



Optional Features:

- Lint trap
- Mounting base, 10" or 6"

Why Purchase Milnor?

- Greater cylinder perforated-area generates *better wash quality, better rinsing and better extraction.* **BENEFIT: Better extraction saves dryer fuel.**
- Faster process times reduce fabric wear, promoting *longer linen life!* **BENEFIT: Saves linen replacement costs.**
- Tall perforated ribs provide excellent lift and high drop. **BENEFIT: Greater mechanical action (M.A.F.) leads to better wash quality.**
- 90-G extract provides excellent moisture removal. Lower extract speeds are available for uniforms, delicate textiles and blended fabrics. **BENEFIT: Better extraction saves dryer fuel.**
- E-P Express® Controller with back-lit LCD display allows operator to choose formulas from real words, not codes. Standard controller features English/Spanish (other languages optional). Controller also provides diagnostic and error messages. Shortens training time of new employees. **BENEFIT: Fewer operator errors.**
- Superior product support through local, highly-skilled dealers. **BENEFIT: Faster repairs mean less downtime.**



Safe chemical injection



Superior cylinder design

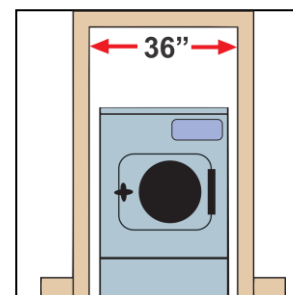

Fits through 3'-0" door

Contact Milnor for your local, authorized dealer:

Pellerin Milnor Corporation
P.O. Box 400 • Kenner, LA 70063
t: 504-467-9591 • f: 504-468-3094

