

MWT27E5

60 lb. (27 kg) Capacity Rigid-Mount Washer-Extractor Specification Sheet



milnor.com



STANDARD FEATURES:

- 3 speeds
- E-P OneTouch® programmable controller
- Single-motor inverter drive
- Tall, lifting ribs
- Sealed ball bearings
- High M.A.F. (Mechanical Action Factor)
- Large cylinder perforations
- Fresh-water flushing chemical manifold
- Auto tension V-belt drive
- Three (3) liquid chemical injection ports
- 5-year limited warranty on frame, cylinder & shell



OPTIONAL FEATURES:

- Lint trap
- Mounting base

Why Purchase Milnor?

BENEFIT: Saves linen replacement costs. Faster process times reduce fabric wear, promoting longer linen life!

BENEFIT: Greater mechanical action (M.A.F.) leads to better wash quality. Greater cylinder perforated area, tall rib construction and precise cylinder speeds generate better cleaning results, better rinsing, and better extraction.

BENEFIT: Better extraction saves dryer fuel. 100-G high extract provides excellent moisture removal. Lower extract speeds are available for uniforms, delicate textiles and blended fabrics.

BENEFIT: Fewer operator errors. E-P OneTouch Controller with simple, push-button controls allow for four separate wash formulas. Indicator lights signal when machine is in operation and prompts operator when machine is moving into final wash formula stage. Shortens training time of new employees.

BENEFIT: Faster repairs mean less downtime. Superior product support through local, skilled dealers.

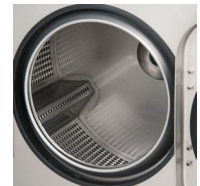

Superior cylinder design

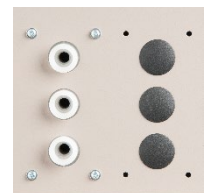

Safe chemical injection

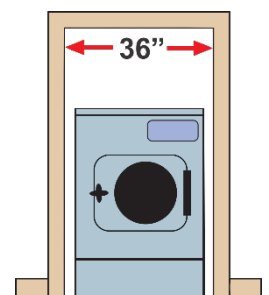

Solid industrial frame

Contact Milnor for your local, authorized dealer:

PELLERIN MILNOR CORPORATION

P.O. Box 400, Kenner, LA 70063 • t: 504-467-9591 • milnorinfo@milnor.com

MWT27E5

60 lb. (27 kg) Capacity Rigid-Mount Washer-Extractor Specification Sheet



milnor.com

LEGEND

C	Cold water inlet, .75" (19 mm) GHT
D	Drain, 3" (76 mm) ID hose
E	Electrical connection
F	Foundation pads, anchor bolt holes .8125" (21 mm) diameter
G	Hot water inlet for soap chute
H	Hot water inlet, .75" (19 mm) GHT
L1	Soap chute
L2	Liquid supply inlets

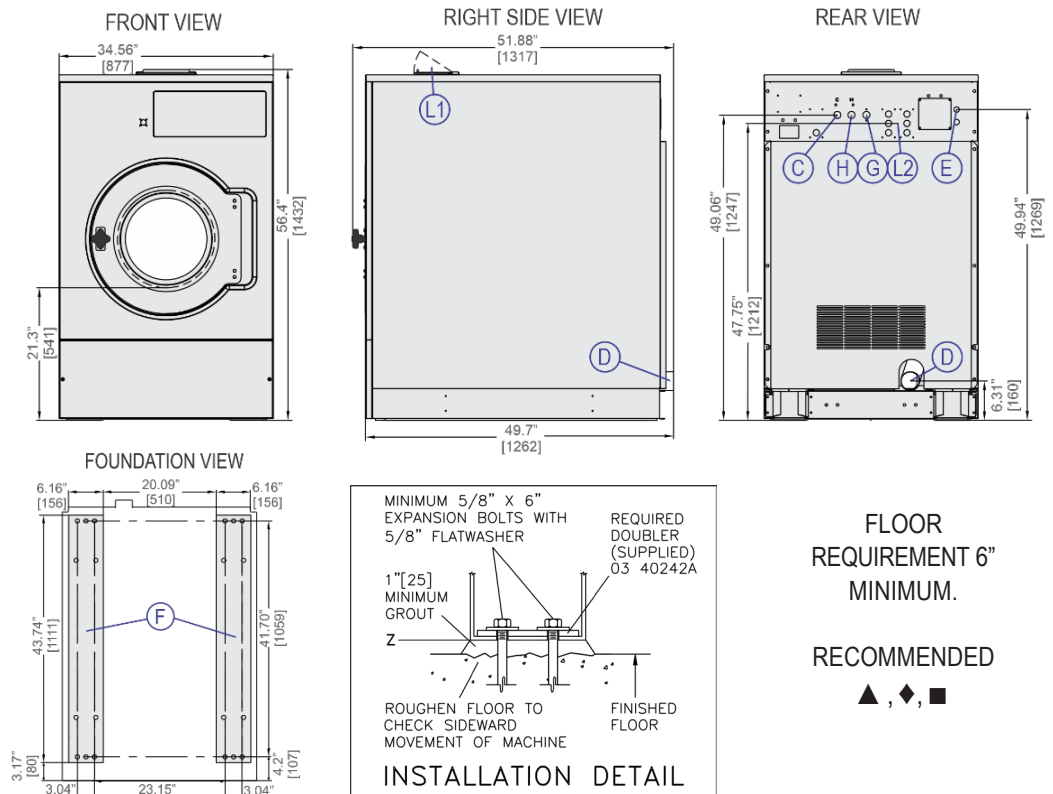

MECHANICAL SPECIFICATIONS

Capacity – lb. (kg)	60 (27)
Cylinder Diameter x Depth – in. (mm)	30 x 22 (762 x 559)
Cylinder Volume – cu. ft. (L)	9 (255)
Door Opening – in. (mm)	15.70 (399)
Machine Dimensions (W x D x H) – in. (mm)	34.56 x 51.88 x 56.4 (877 x 1317 x 1432)
Shipping Dimensions (W x D x H) – in. (mm)	40.35 x 54.92 x 60.67 (1025 x 1395 x 1541)
Motor – HP (kW)	4 (3.0)
Wash Speed – RPM	38
Distribution Speed – RPM	65
Extraction Speed – RPM	485
Extraction G-Force	100
Static Weight – lb. (kg)◆	1567 (711)
Max. Dynamic Load RMS – lb. (kg)◆	1200 (545)
Frequency – Hz◆	8.07
Water Pressure ^(Required) – psi (bar)	10-75 (.68-5.1)
Water Valve - Cv Rating at 72°F (22°C)	0.92 (3.5)
Minimum Recommended Distance Between Machines – in. (mm)	0

Specifications and appearance subject to change without notification.
B22SS16016/26226

ELECTRICAL SPECIFICATIONS

Voltage	Running Amps	Fuse (Amps)	Circuit Breaker (Amps)
220/3/50	5	FRN15	15
208, 240/1/60	8, 7	FRN20	20
208, 240/3/60	6, 5	FRN15	15
380/3/50-60	3.5	FRS15	15
480/3/60	2.5	FRS15	15

See Fuse and Wire Size manual MAEFUSE1BE for safety information. Contact factory regarding single phase availability.

▲ See dimensional drawing for complete details.

◆ It is the sole responsibility of the owner/user to assure that the floor and/ or any other supporting structure exceeds not only all applicable building codes, but also that the floor and/ or any other supporting structure for each washer-extractor or group of washer-extractors has sufficient strength and rigidity (i.e., a natural or resonant frequency many times greater than the rotational machine speed with a reasonable factory of safety) to support the weight of all the fully loaded machine(s) including the weight of the water and goods, and including the published 360° rotating sinusoidal RMS forces that are transmitted by the machine(s). Contact the factory for additional machine data for use by a structural engineer.

■ Machine bases made from concrete should either be part of a monolithic pour or should be tied into foundation and not isolated from existing floor.