

Goulds Pump Type NOB Pump Seal Replacement

Preparation:

1. Assemble your necessary parts and tools. You will need a new Pump Seal Kit from Milnor for your model of pump. The pump shown is a 1 1/2 X 2 - 6, which is a size 3SN. The pump impeller size is 4 7/16. You will also need an o-ring for the pump cavity and some quality grade o-ring grease/lubricant. Vitaulic grease is a good type. You will also need some Loctite 242 or 243.



Procedure:

1. Disconnect the motor electrically and the pump mechanically from the system. Set the pump on a clean work bench where you will have room to work.

2. Remove the (8) 3/16 allen bolts that hold the pump cavity end cap in place. The bottom (4) allen bolts also hold the pump mounting bracket. Set the bolts aside. The end cap may take a little bit of pulling to separate from the pump. There is an internal O-ring that helps to create a leak tight joint between the two pieces that comprise the pump cavity.



3. Remove the Impeller from the shaft. To do this you will need to remove the end cap from the cooling fan. To keep the impeller shaft from rotating, you can apply a 1/2" wrench to the end of the shaft at the cooling fan to apply counterforce and keep the shaft from turning. Use a straight bar like a long screwdriver to break the impeller free. From that point, you should be able to turn the impeller by hand. In some cases, you may need to heat the impeller/shaft to loosen the loctite.

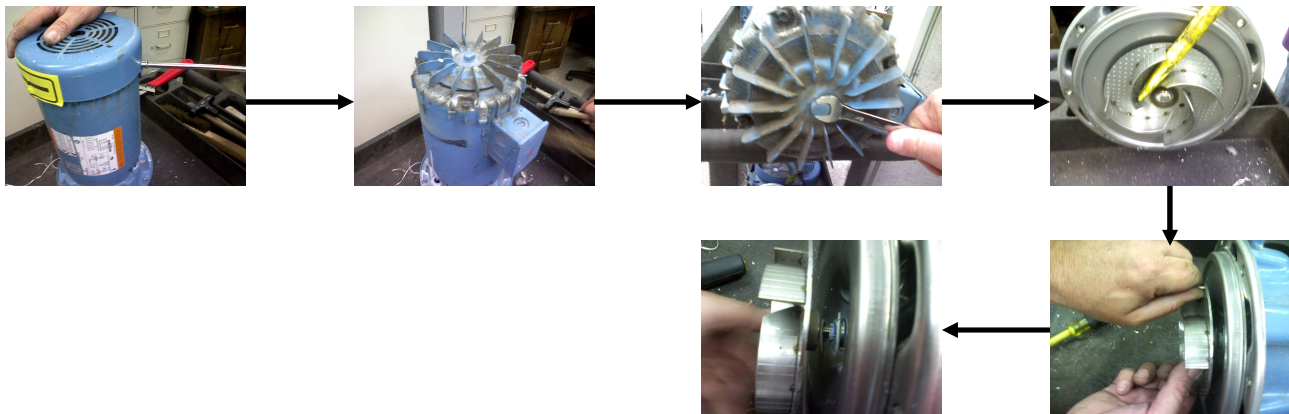

4. Remove and discard the spring. There is a washer on the end of the seal head. Remove this washer and set it aside for reassembly. The mechanical seal rotary assembly needs to be removed. Depending on the age and condition of the mechanical seal rotary assembly, you may need to use a set of pliers to apply an amount of rotational force to break it free.



5. You will now be able to remove the seal housing. The seal housing has a seal flush pipe connection that is oriented in the Motor Adaptor. The mechanical seal stationary seat will slide from the motor shaft with the seal housing. Push the mechanical seal stationary seat out of the seal housing. Discard the old mechanical seal stationary seat.

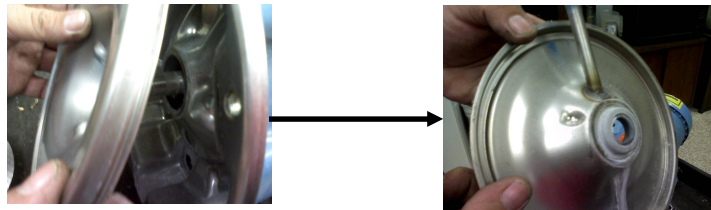

6. Removal of the motor adaptor by removing the 4 bolts will allow cleaning of the shaft. Hold a scotchbrite scouring pad/emery cloth or equivalent around the shaft while turning the shaft by hand. A little bit of water will facilitate the removal of the chemical residue on the shaft. Doing this gives the new mechanical seal stationary seat a clean shaft surface to seal against. Avoid making flat spots or reducing shaft diameter.

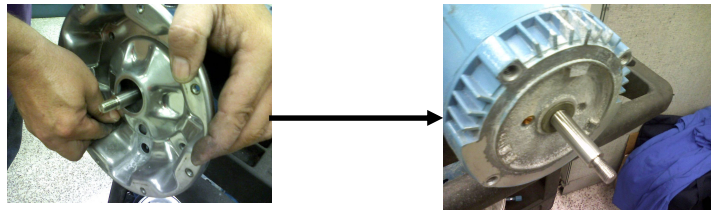

7. Lubricate the outer elastomer of the mechanical seal stationary seat. Viton lubricant or any other quality grade O-ring lubricant will work. Push in the new mechanical seal stationary seat into the seal housing. This can be hand pressed or driven into place taking care to protect the sealing face from a direct blow with any metal object. Use a piece of plastic between the face and any driving force. Carefully wipe the seat face clean of lubricant or debris.



8. Reattach the motor adaptor back to the motor using the 4 attaching bolts.



9. Install the seal housing with the new mechanical seal stationary seat into the motor adaptor. Lubricating the shaft with some viton lubricant can aid in sliding the assembly into place. Seating surfaces should not be lubricated.



10. Check both seating surfaces to assure they are free of any foreign matter, grease, and finger prints. Slide the mechanical seal rotary assembly on the shaft. Ensure that there is no lubricant on the seating surfaces between the mechanical seal rotary assembly and the stationary seat.



11. Install the washer on the end of the shaft that was previously removed during the disassembly procedure. Install the spring. Make sure that the spring engages the shoulder of the seal head. When installing the impeller, ensure the threads are clean and apply a small amount of Loctite 7649 primer to the threads. Wait about 2-3 minutes and use either Loctite 242 or 243 on the threads, screw the impeller in place. Torque the impeller to a value of 144 in-lbs.

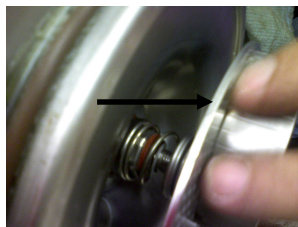

12. Lubricate and install a new casing O-ring to the Seal Housing.



13. Lubricate the casing where it seals against the O-ring on the seal housing. Install the pump casing and secure using the (8) allen head cap screws. The bottom 4 screws hold the mounting bracket in place. Tighten with a cross pattern sequence to ensure the casing is pulled down evenly. Torque the cap screws to 70 in-lbs. The motor mount has a rubber guard on the support for the motor. If this rubber guard has deteriorated, a new one can be fashioned using a piece of small diameter rubber hose and cutting a slit down the length of the hose.



14. Reinstall the motor cooling fan guard.



Note: During this rebuilding process, you note any damaged internal parts of the pump, repair parts can be ordered through Milnor Parts.

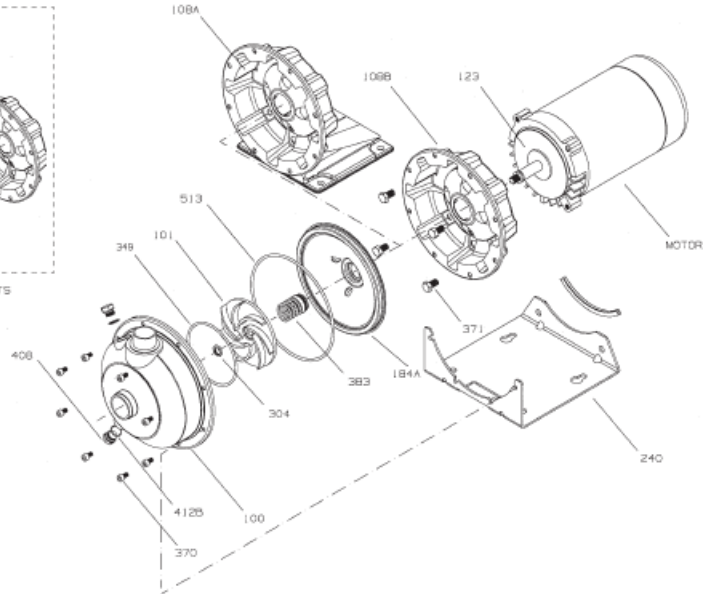
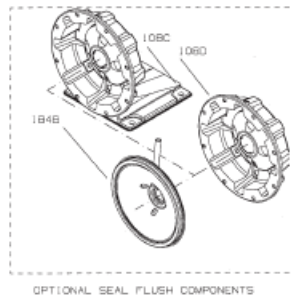

Item No.	Description	Materials of Construction	1SN 1 x 1¼	2SN 1¼ x 1½	3SN 1½ x 2	Qty.
100	Casing	AISI 316L SS	1L499	1L440	1L441	1
101	Impeller		See Impeller Chart			
108A	Motor adapter with foot	AISI 316L SS		1L80		1
108B	without foot			1L87		
108C	with foot and flush			1L334		
108D	without foot and flush			1L335		
123	Deflector	BUNA-N		5K7		1
184A	Seal housing – standard	AISI 316L SS		1L79		1
184B	Seal housing with seal flush			1L333		
240	Motor support	300 SS		4L320		1
	Rubber channel	Rubber		9K188		1
304	Impeller locknut	AISI 316 SS		13K286		1
349	O-ring, internal	Viton standard	5L109		NR	1
		EPR	5K252		NR	
370	Socket head screw, casing	AISI 430 SS		13L65		8
371	Bolts, motor	Steel/plated		13K252		4
383	Mechanical seal	See Mechanical Seal Chart				1
408	Drain and vent plug, casing	AISI 316 SS		6L3		2
412B	O-ring, drain plugs	Viton standard		5L99		2
		EPR		5L80		
513	O-ring, casing	Viton standard		5K206		1
		EPR		5K193		