

FLUSHING WATER SEALS AND LEAK - OFFS FOR THE Q STYLE BEARING HOUSING

MSSM0273AE/9704AV

DANGER: ENTANGLE AND CRUSH HAZARD



Contact with moving components normally isolated by guards, covers, and panels, can entangle and crush your limbs. These components move automatically.

 Do not service unless qualified and authorized.

 Lock OFF and tag out power at the before servicing the bearing housing.

Required Kits—This procedure requires bulb pump kit (p/n KZ5CP00100), one gallon (3.8 liters) of mineral spirits, a hand operated grease pump, and the specified lubricants.

Background Information—36Q6x, 36Fxx and 42Fxx open pocket machines are supplied with grease filled bearing housings fitted with two water seals and a grease seal as shown in FIGURES 1 and 2. Bath liquor is prevented from entering the bearings by two water seals separated by grease filled cavity (FIGURE 2). Any water leaking past the water seals is drained by the leak-off cavity. The grease seal retains the grease in the housing. The seal grease cavity and the leak-off cavity can become clogged with lint and debris, resulting in seal and bearing failure. Every six months, flush out these cavities with mineral spirits, as described within. Normally, flushing is done less often than greasing. However, whenever flushing is due, it should be done just prior to greasing, during the same maintenance session.

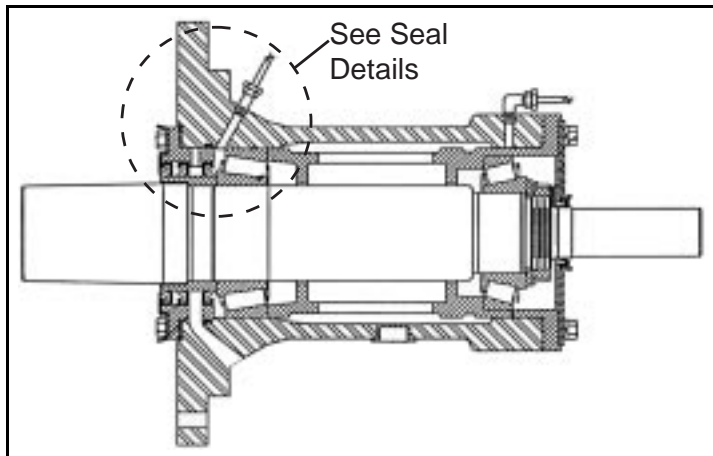

FIGURE 1 (MSSM0273AE) — Typical Bearing Housing for Q style Washer-Extractor

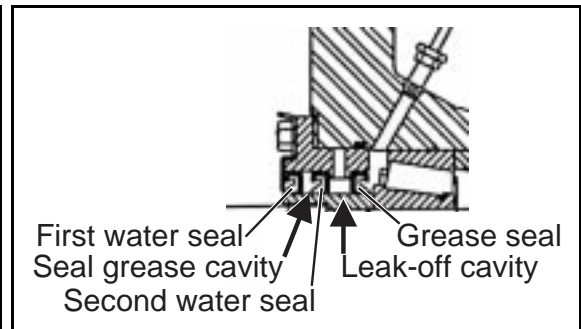

FIGURE 2 (MSSM0273AE) — Seal Details

NOTICE: BEARING DAMAGE HAZARD



BEARING DAMAGE HAZARD—Bearings will quickly burn up if grease is contaminated by mineral spirits.

☞ **DO NOT attempt to force mineral spirits into the bearing housing.** If mineral spirits do not flow easily through the seal cavity grease relief and leak-off, ream out grease relief and leak-off drains.

☞ **DO NOT attempt to flush the main or rear bearing.**

Flushing the Seal Grease Cavity—Before beginning, study the main bearing assembly drawing in the service manual to identify inlets, connections, reliefs, and leak-offs.

1. Locate the tubing running from the seal cavity grease point to the bearing housing (FIGURE 3). Disconnect this tubing at the bearing housing.

2. Install the bulb pump.

3. Remove the seal cavity grease relief fitting (if so equipped) to prevent the mineral spirits and contaminated grease from being pushed back into the shell under the first water seal. FIGURE 4 shows the internal passage from the seal cavity grease inlet to the seal grease cavity and the internal seal cavity relief passage from the seal grease cavity to the seal cavity grease relief fitting (if so equipped) on the housing.

3. Flush until the mineral spirits dripping from the seal cavity grease relief are clear (approximately two quarts - 1.9 liters).

4. Re-install seal cavity grease tubing and grease relief fitting (if so equipped).

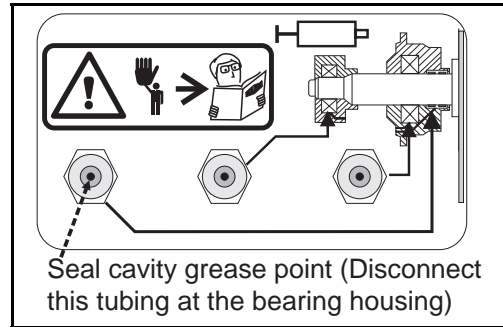

FIGURE 3 (MSSM0273AE)—Identifying the Seal Cavity Grease Point

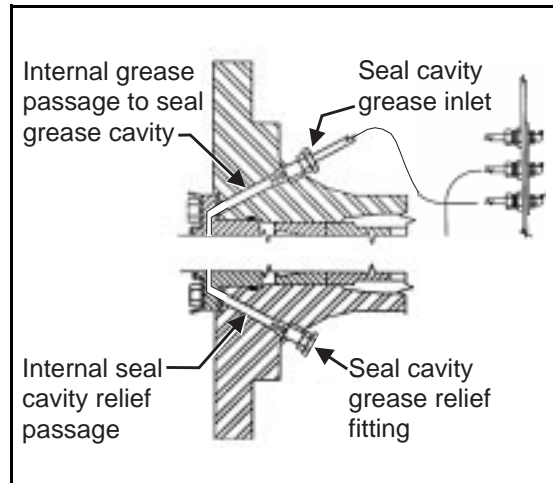

FIGURE 4 (MSSM0273AE) — Internal Seal Cavity Grease Passage and Relief

Flushing the Leak-off Cavity

1. Remove the vented plug at the flushing connection and install the bulb pump.
2. Pump approximately two quarts (1.9 liters) of mineral spirits into the flushing connection until the spirits flow easily out of the leak-off drains. FIGURE 5 shows the internal passage from the flushing inlet, through the leak-off cavity, and the internal drain to the exterior of the housing.
3. After flushing, replace the vented plug, then see "Greasing Seals and Bearings" in the Preventive Maintenance section.

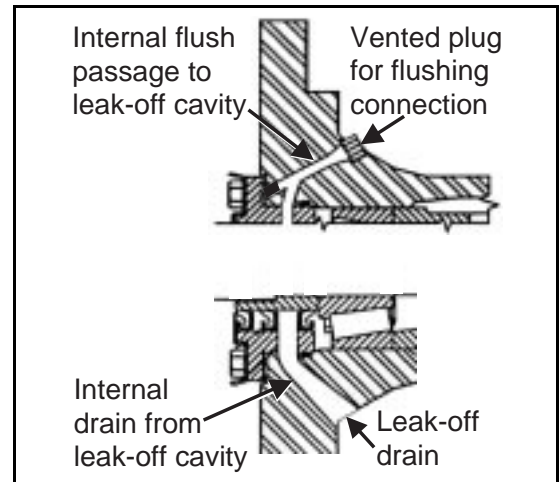

FIGURE 5 (MSSM0273AE) — Internal Flushing Passage and Leak-off